

## AGENDA

### Oakland-Macomb Interceptor Drain Drainage Board Macomb and Oakland Counties

**June 15, 2022 – 11:30 a.m.**

Office of the Oakland County Water Resources Commissioner  
One Public Works, Building 95 West  
Waterford, Michigan, and Microsoft Teams

1. Call meeting to order

Board Members:

Michael Gregg, Chair, Michigan Department of Agriculture and Rural Development  
Candice Miller, Macomb County Public Works Commissioner  
Jim Nash, Oakland County Water Resources Commissioner

2. Motion to approve the meeting agenda for June 15, 2022
3. Motion to approve the Drainage District Board Meeting Minutes from May 18, 2022
4. Public Comment
5. Meadowbrook Insurance NESPS/NIEA Property and Pollution Renewal
6. Meadowbrook Insurance Safety Summary Report
7. Memorandum requesting the Board approve the revised Budget and Flow Allocations for 2022/2023
8. Motion to approve the following Change Orders:
  - a) Rotor Electric Change Order No. 1 for Contract Time Extension and Additional Funding of \$1,000,000
  - b) CSM Mechanical Change Order No. 2 for Contract Time Extension and Additional Funding of \$500,000
  - c) HESCO Change Order No. 1 for Contract Time Extension
  - d) Konecranes Change Order No. 1 for Contract Time Extension
  - e) PM Technologies Change Order No. 1 for Contract Time Extension and Additional Funding of \$500,000
  - f) Kennedy Industries Change Order No. 1 for Contract Time Extension
  - g) Walsh Construction Change Order No. 23 for the NESPS Pump & Electrical Upgrades Project for a net increase in the amount of \$878,254.81

9. Motion to approve the following Construction Estimates:
- a) Construction Estimate No.20 for Walsh Construction for NESPS Pump & Electrical Upgrades Project (GMP Phase) in the amount of \$857,532.32 with a transfer to the Oakland County Treasurer in the amount of \$4,053.82
  - b) Construction Estimate No. 15 for Marra Services for NI-EA Contract No. One for PCI 4 Rehabilitation in the amount of \$184,190.88
10. Report/Update – Status of OMID Repairs Project
11. Financial Reports – General Financial Report and Status of State Revolving Fund Financing and Other Financing
12. Motion to approve the following invoices:
- a) Reimbursement of Oakland County WRC-Incurred Expenses and Costs
    - 1) Reimbursement
      - Macomb Invoice No. ARP220128 \$ 26,291.30
  - b) ASI
 

Invoice No. 40	O&M	\$ 76,734.80
----------------	-----	--------------
  - c) CH2M
 

Invoice No. 40-705773CH039	O&M	\$ 1,407.08
----------------------------	-----	-------------
  - d) Clark Hill
    - 1) Invoice No. 1202217 NI-EA \$ 1,782.00
    - 2) Invoice No. 1202243 NI-EA \$ 5,335.00
  - e) CSM
 

Invoice No. 21OMIDD016	O&M	\$ 12,964.30
------------------------	-----	--------------
  - f) GLWA
 

Invoice No. 900-2101-W	NESPS	\$ 133.00
------------------------	-------	-----------
  - g) Hesco
 

Invoice No. 2213585	O&M	\$ 3,815.00
---------------------	-----	-------------
  - h) Kennedy Industries
 

Invoice No. 631379	O&M	\$ 396.00
--------------------	-----	-----------
  - i) Meadowbrook Insurance
 

Invoice No. 7933	NESPS	\$ 44,200.00
------------------	-------	--------------
  - j) Metco
 

Invoice No. 1811-41	O&M	\$ 98,405.61
---------------------	-----	--------------
  - k) Motor City Electric Company
    - 1) Invoice No. 94498 O&M \$ 180.00
    - 2) Invoice No. 94499 O&M \$ 225.00
    - 3) Invoice No. 94501 O&M \$ 90.00
  - l) NTH Consultants, Ltd
    - 1) OMID System Immediate Repairs
 

Invoice No. 629630	O&M	\$ 520.78
--------------------	-----	-----------
    - 2) Engineering Design Services Rehabilitation of NI-EA Sections PCI-4
 

Invoice No. 629631	NI-EA	\$ 51,082.62
--------------------	-------	--------------
    - 3) Contract No. 1 PCI-4
 

Invoice No. 629632	NI-EA	\$ 91,830.60
--------------------	-------	--------------
    - 4) Eng./Consulting Services NESPS Upgrade
 

Invoice No. 629634	NESPS	\$ 990.61
--------------------	-------	-----------

5)	Consulting Services – System Inspection Invoice No. 629635	O&M	\$	3,085.34
6)	Rehabilitation Program 2021 Closeout Services Invoice No. 629636	O&M	\$	914.18
7)	Additional NESPS Maintenance Eng. Services Invoice No. 629637	NESPS	\$	616.93
m)	PMA Consultants Invoice No. 03559.01-24	O&M	\$	16,999.58

13. Other Business

14. Adjourn

Next Regular Meeting: July 20, 2022, 11:30 a.m., Eastern Standard Time.

**Agenda Item No. 3**

Board Meeting Minutes from May 18, 2022

**MINUTES OF THE REGULAR MEETING OF THE DRAINAGE BOARD  
FOR THE OAKLAND-MACOMB INTERCEPTOR DRAIN DRAINAGE DISTRICT**

May 18, 2022

Minutes of the regular meeting of the Drainage Board of the Oakland-Macomb Interceptor Drain Drainage District held at the office of the Oakland County Water Resources Commissioner, One Public Works Drive, Building 95 West, Waterford, Michigan on the 18<sup>th</sup> day of May at 11:30 a.m. Eastern Standard Time and via Microsoft Teams.

**PRESENT:**

Michael Gregg, Chairperson and Deputy for Gary McDowell, Director of the Michigan Department of Agriculture and Rural Development; Candice Miller, Member and Macomb County Public Works Commissioner; and Jim Nash, Secretary and Oakland County Water Resources Commissioner.

**OTHERS PRESENT:**

Representing the office of the Macomb County Public Works Commissioner: Brian Baker, Stephen Downing and Norb Franz. Representing the office of the Oakland County Water Resources Commissioner: Anne Vaara, Steve Korth, Brian Coburn, Raphael Chirolla, Sid Lockhart, Joel Brown, Megan Koss, Kelsey Cooke, and Stephanie Lajdziak. Others in attendance: Brady Harrington, MDARD; Fritz Klingler, FK Engineering; Terry Moore, Metco; Jeff Ragle, OC Fiscal Services; Michelle Kitzinger, Larry Gilbert and Saju Sachidanandan, NTH Consultants; Joe Colaianne, Clark Hill; and Pete Webster, Dickinson Wright

1. Call meeting to order.

Chairperson Gregg called the meeting to order at 11:31 a.m.

2. Agenda.

Motion by Nash, supported by Miller, to approve the May 18, 2022, agenda as presented.

ADOPTED: Yeas - 3  
              Nays - 0

3. Minutes.

Motion by Nash, supported by Miller, to approve the minutes of the April 20, 2022, meeting.

ADOPTED: Yeas - 3  
              Nays - 0

4. Public Comment.

None.

5. GLWA/Highland Park Litigation/ Closed Session

A motion was made by Miller, supported by Nash, to enter into closed session at 11:34 a.m. to discuss a memorandum from the Drainage District's attorneys as permitted under section

8(h) of the Open Meetings Act and which is exempt from public disclosure as subject to the attorney-client privilege pursuant to section 13(1)(g) of the Freedom of Information Act.

ADOPTED: Yeas - 3  
Nays - 0

Chairperson Gregg declared the closed session ended at 12:39 p.m.

It was moved by Miller, supported by Nash, to authorize the Drainage District's legal counsel to proceed consistent with the discussion in closed session.

ADOPTED: Yeas - 3  
Nays - 0

6. OMID Odor and Corrosion Control Design Budget and Project Creation

A memorandum from Joel Brown and Stephen Downing requesting the Board to approve the budget of \$1,030,000 for the design of OMID Odor and Corrosion Control Systems and authorize a project be created for this work was presented. Motion by Nash, supported by Miller, to approve the budget and authorize a project be created as presented.

ADOPTED: Yeas - 3  
Nays - 0

7. Engineering Work Order.

The following Engineering Work Orders were submitted to the Board for approval:

- a) ASI Engineering Work Order No. D-447 for the Design of the OMID Flow Control Structure Rehabilitation Project and Approval of Design budget for a not-to-exceed amount of \$220,326 and creation of a project for this work with a not-to-exceed budget of \$354,000. Motion by Miller, supported by Nash, to approve the Engineering Work Order as presented.

ADOPTED: Yeas - 3  
Nays - 0

8. Change Order.

The following Change Orders were submitted to the Board for approval:

- a) Walsh Construction Change Order No. 22 for the NESPS Pump & Electrical Upgrades Project for a net increase in the amount of \$49,846.33. Motion by Nash, supported by Miller, to approve the Change Order as presented.

ADOPTED: Yeas - 3  
Nays - 0

9. Construction Pay Estimates.

The following Construction Pay Estimates were submitted to the Board for approval:

- a) Construction Estimate No. 19 for Walsh Construction for NESPS Pump & Electrical Upgrades Project (GMP Phase) in the amount of \$1,263,378.00 with a transfer to the Oakland County Treasurer in the amount of \$139,301.82. Motion by Miller, supported by Nash, to approve the Construction Pay Estimate as presented.

ADOPTED: Yeas - 3  
Nays - 0

- b) Construction Estimate No. 14 for Marra Services for NIEA Contract No. One for PCI 4 Rehabilitation in the amount of \$689,624.00. Motion by Nash, supported by Miller, to approve the Construction Pay Estimate as presented.

ADOPTED: Yeas - 3  
Nays - 0

- c) Final Construction Estimate No. 41 for Inland Waters Pollution Control, Inc. for OMID Segment 2, Contract 3 in the amount of \$907.96. Motion by Miller, supported by Nash, to approve the Construction Pay Estimate as presented.

ADOPTED: Yeas - 3  
Nays - 0

- d) Final Construction Estimate No. 20 for Inland Waters Pollution Control, Inc. for OMID Segment 2, Contract 3 – Emergency Gatehouse Repairs in the amount of \$6,718.58. Motion by Nash, supported by Miller, to approve the Construction Pay Estimate as presented.

ADOPTED: Yeas - 3  
Nays - 0

10. Report/Update – Status of OMI Project, Segments 1 through 4, NESPS and NI-EA.  
Fritz Klingler of FK Engineering presented the Project Progress Update to the Board and summarized the status of various projects. Motion by Nash, supported by Miller, to receive and file the report and summary.

ADOPTED: Yeas - 3  
Nays - 0

11. Financial Reports.  
Steve Korth presented the financial reports for Segments 1 through 5 and the NESPS. Motion by Miller, supported by Nash, to receive and file the financial reports.

ADOPTED: Yeas - 3  
Nays - 0

12. Invoices.  
The following invoices were submitted to the Board for approval:  
a) Reimbursement of Oakland County WRC-Incurred Expenses and Costs  
1) Labor/Fringes/Non-Direct Labor Factor

	• Segment 5 NI-EA Construction		\$	12,581.90
	• Segment 5 NESPS Mech./Elect. Construction		\$	29,521.82
2)	Equipment Charges			
	• Segment 5 NI-EA Construction		\$	388.89
	• Segment 5 NESPS Mech./Elect. Construction		\$	2,360.25
b)	ASI			
	Invoice No. 39-8118	NESPS	\$	81,929.72
c)	CH2M			
	Invoice No. 705773CH038-09	O&M	\$	1,190.42
d)	Clark Hill			
	1) Invoice No. 1194098	NI-EA	\$	297.00
	2) Invoice No. 1194100	NI-EA	\$	918.00
e)	CSM			
	Invoice No. 21OMIDD-017	O&M	\$	2,469.67
f)	Hesco			
	Invoice No. 2213585	O&M	\$	3,815.00
g)	Kennedy Industries			
	1) Invoice No. 628439	O&M	\$	858.00
	2) Invoice No. 629779	O&M	\$	1,089.00
	3) Invoice No. 630060	O&M	\$	1,160.50
	4) Invoice No. 630563	O&M	\$	393.00
	5) Invoice No. 630924	O&M	\$	10,485.20
h)	METCO			
	Invoice No. 1811-40	O&M	\$	78,135.01
i)	Motor City Electric Company			
	1) Invoice No. 94396	O&M	\$	2,036.26
	2) Invoice No. 94403	O&M	\$	90.00
	3) Invoice No. 94404	O&M	\$	90.00
	4) Invoice No. 94405	O&M	\$	90.00
	5) Invoice No. 94412	O&M	\$	327.48
	6) Invoice No. 94419	O&M	\$	342.00
	7) Invoice No. 94420	O&M	\$	446.35
j)	NTH Consultants, Ltd			
	1) Supplementary Support Services at NESPS			
	Invoice No. 629360	O&M	\$	10,686.72
	2) Consulting Services for System Inspect.			
	Invoice No. 629358	O&M	\$	1,438.80
	3) Contract No. 1 PCI-4			
	Invoice No. 629355	NI-EA	\$	100,353.03
	4) NI-EA – Engineering Design Services Rehabilitation of NI-EA Sections PCI-4			
	Invoice No. 629354	NI-EA	\$	4,390.07
	5) Eng./Consult. Services NESPS CMT			
	Invoice No. 629357	NESPS	\$	977.55
	6) Rehabilitation Program 2021 Closeout Services			
	Invoice No. 629359	O&M	\$	3,215.62
k)	PM Technologies			
	1) Invoice No. 165277	O&M	\$	875.10
	2) Invoice No. 165278	O&M	\$	875.10



3)	Invoice No. 165802	O&M	\$	2,895.00
4)	Invoice No. 165803	O&M	\$	2,895.00
5)	Invoice No. 165842	O&M	\$	2,895.00
6)	Invoice No. 165276	O&M	\$	1,002.60
l)	PMA Consultants			
	Invoice No. 3559.01-23	NI-EA	\$	13,393.61
m)	Rotor Electric Company			
1)	Invoice No. 12502	O&M	\$	3,716.20
2)	Invoice No. 12503	O&M	\$	5,242.56
3)	Invoice No. 12504	O&M	\$	2,367.50
4)	Invoice No. 12511	O&M	\$	2,466.00
5)	Invoice No. 12512	O&M	\$	2,466.00
6)	Invoice No. 12513	O&M	\$	7,124.00
7)	Invoice No. 12514	O&M	\$	7,124.00
8)	Invoice No. 12515	O&M	\$	7,946.00
9)	Invoice No. 12516	O&M	\$	3,033.62
10)	Invoice No. 12517	O&M	\$	14,465.35

Motion by Miller, supported by Nash, to approve the invoices as presented.

ADOPTED: Yeas - 3  
Nays - 0

13. Other Business.

Sid Lockhart presented the Board with hard hats affixed with the WRC logo.

14. Adjourn.

Motion by Nash, supported by Miller, to adjourn the May 18, 2022, meeting at 1:26 p.m.

ADOPTED: Yeas - 3  
Nays - 0

Next Regular Meeting: June 15, 2022, at the *Office of the Oakland County Water Resources Commissioner, One Public Works, Building 95 West, Waterford, Michigan* and electronically at 11:30 a.m., Eastern Standard Time.

I hereby certify that the foregoing constitutes the minutes of the Drainage Board for the Oakland-Macomb Interceptor Drain Drainage District, at a meeting held on May 18, 2022 and that the meeting was conducted and public notice was given in compliance with the Open Meetings Act being Act 267, Public Acts of Michigan, 1976, as amended, and that the minutes were kept and will be or have been made available to the public as required by the Act.

IN WITNESS WHEREOF, I have hereunto affixed my official signature on this 18<sup>th</sup> day of May 2022



---

Jim Nash, Secretary  
Oakland-Macomb Interceptor Drain Drainage Board

## **Agenda Item No. 4**

Public Comment

**Agenda Item No. 5**

NESPS/NI-EA  
Property and Pollution Insurance Renewal



# **Oakland-Macomb Interceptor Drain Drainage District: NESPS/NIEA**

*One Public Works Drive, Building 95 West, Waterford, MI 48328*

## **Proposal for Property & Pollution Liability Insurance**

**07/01/2022**

*to*

**07/01/2023**

*(dated 6/1/22)*

*Sal Saputo, Executive Vice President*  
 **MEADOWBROOK**  
INSURANCE AGENCY.  
[www.meadowbrookagency.com](http://www.meadowbrookagency.com)

# **Oakland-Macomb Interceptor Drain Drainage District: Northeast Sewage Pumping Station / North Interceptor-East Arm**

## **Marketing Summary 07/01/2022 to 07/01/2023**

---

### **NESPS/NIEA July Property and Pollution Renewal Summary**

We have completed the renewal process for the NESPS/NIEA insurance program renewing July 1st, 2022. The hardening marketplace continues to be a major challenge through most lines of coverage, with carriers reducing capacity, increasing rates and in some cases, withdrawing from certain segments of the market altogether. The total overall renewal premium for the July insurance policies increased from \$273,012 at expiring to \$302,957(+10.9%) at renewal. We have summarized the 2022-23 renewal effort by line of coverage below:

**Property Coverage:** The current Chubb property policy was written on a (2) year term in 2021 and we are at the first renewal of the policy. We had discussions with the property insurance markets however based on appetite, coverage, and price Chubb was still the best carrier to place the coverage. The property renewal includes a 6.2% increase in total insurable values based on the Engineering News Record Construction Cost Index, and a 5% property rate increase putting the total annual premium at \$286,612, which is an 11.2% overall increase. Locking in the two-year term in 2021 was extremely beneficial due to current market conditions, industry loss history, and high level of inflation. Based on current and recent efforts with similar exposures (NESPS/NIEA, OMIDD, Oakland County, Evergreen-Farmington) Chubb is currently the best carrier to continue your coverage for the next year.

**Pollution Liability:** AIG is the current pollution carrier. We had early conversations in advance of the renewal and agreed to a very favorable rate this year. The premium is based on budgeted maintenance payroll which increased 8.4% from \$2,063,000 to \$2,237,780 while the total policy premium increased only 2%. This equates to a net rate decrease of 6.4%.

# Oakland-Macomb Interceptor Drain Drainage District: Northeast Sewage Pumping Station / North Interceptor-East Arm Program Comparison

Property Renewal Comparison		
	21-22	22-23
Carrier	Chubb	Chubb
AM Best Rating	A+ XV	A+ XV
Policy Term (Two-year option w/ +5% rate per multi-year ends)	7-1-21/22	7-1-22/23
Premium	\$257,297	\$286,912
TRIA	incl	Incl
Engineering Fee	NA	NA
TIV	\$284M	\$301M
Rate / \$100 TIV	.0906	.0951
Policy limit	150M	150M
Deductible	1M	1M
Debris removal	25% or \$10M whichever is lesser	25% or \$10M whichever is lesser
Machinery Breakdown	Policy Limit \$150M	Policy Limit \$150M
<i>Other significant Sub-Limits</i>		
<i>Earth Movement</i>	50M	50M
Flood sub-limit	10M	10M
Demolition Cover A, B, C	10M	10M
Errors & Omissions	5M	5M
Extra Expense	2.5M	2.5M

Pollution Renewal Comparison		
	21-22	22-23
Carrier	AIG	AIG
AM Best Rating	A XV	A XV
Policy Term	7-1-21/22	7-1-22/23
Premium	\$15,715.30	\$16,045.35
Policy Limit	10M	10M
Deductible	50k	50k
TRIA	incl	Incl
Exposure Base (Maintenance Budget)	2,063,000	2,237,780

# Oakland-Macomb Interceptor Drain Drainage District: Northeast Sewage Pumping Station / North Interceptor-East Arm 07/01/2022 to 07/01/2023

## Premium Summary

POLICIES	Expiring 2021-2022	Proposed 2022-2023
Property [1] [2] ACE American Insurance Co.	\$257,297.00 TIV: \$284,000,878	\$286,912.00 TIV: \$301,608,932
Pollution Liability [3] AIG Specialty Insurance Company	15,715.30	16,045.35
<b>TOTAL PREMIUM [4]</b>	<b>\$273,012.30</b>	<b>\$302,957.35</b>

[1] Total Insurable Value is increasing by the May 2022 ENR Factor of 6.2%

[2] This is the 2<sup>nd</sup> year of the multi-year property endorsement capping Chubb's rate increase at 5%.

[3] The premium is based on budgeted maintenance payroll which increased 8.4% from \$2,063,000 to \$2,237,780 while the total policy premium increased only 2%. This equates to a new rate decrease of 6.4%

[4] Total premium is increasing by 10.9%

## Premium Payment Plans

<p><b>Pay in Full Agency Bill</b></p>
---

*This document does not amend, extend, or alter coverage afforded by the policy. For a complete understanding of any insurance you purchase, you must first read your policy, declaration page, and any endorsements and discuss them with your Meadowbrook agent. A specimen policy may also be available for your review from the insurance company. Actual policy conditions may be amended by endorsement or state law."*

*Meadowbrook, Inc. strives to place your insurance with financially-sound insurance carriers. There are many financial rating companies who assign credit ratings to participating insurance carriers (i.e., A.M. Best Company). These ratings are the financial rating company's independent opinion about the financial stability of the insurance carrier and, as a result, vary among insurance carriers. Not all insurance carriers choose to be rated by these services. Please be aware of this rating, or lack thereof, for the insurance carrier listed on your proposal. Meadowbrook, Inc. is not responsible for, nor guarantees, the financial solvency of any insurance carrier through which it places your insurance.*

*We are pleased to present this insurance proposal and thank you for the opportunity. We look forward to serving you in the future.*



**Agenda Item No. 6**

Meadowbrook Insurance  
Safety Summary Report

## OCIP Safety Summary Report

### June 15<sup>th</sup>, 2022

<b>Owner:</b>	Oakland Macomb Interceptor Drain Drainage District	
<b>Project 1:</b>	Northeast Sewage Pump Station Odor Control Project (Completed)	
<b>Project 2:</b>	Northeast Sewage Pump Station Renovation (Active)	
<b>Project 3:</b>	North Interceptor – East Arm Rehabilitation Project (Active)	
<b>GC/CM:</b>	1) CSM 2) Walsh Construction Company, LLC 3) Marra Services, Inc.	
<b>Report Timeline:</b>	Through March 31st, 2022	
<b>OCIP Safety Representative:</b>	Richard Trembath	
Site safety report for the Northeast Sewage Pump Station Renovation and North Interceptor – East Arm Rehabilitation Project. Site is observed as clean, organized, and operating smoothly.		
<b>MIOSHA Data</b>		
<b>NESPS Odor Control Project</b>	Completed Odor Control Project with Zero MIOSHA Recordable Cases	
<b>NESPS Renovation Project</b>	No MIOSHA Recordable Cases for NESPS Renovation Project OCIP Enrolled Contractors	
<b>NI-EA Rehab</b>	No MIOSHA Recordable Cases for PCI-4 Rehabilitation Project OCIP Enrolled Contractors	
<b>Hours and Tasks</b>	<b>NESPS</b>	<b>NI-EA PCI-4</b>
Contractor Hours	75,000	16,415
Job Safety Analysis Performed	55	10
Lifting Safety Plans Reviewed	0	3
Safety Plan Revisions	0	1
Toolbox Talks	230	60
Lost Time Injuries	0	0
<b>Ongoing Operations &amp; Accomplishments</b>		
<ul style="list-style-type: none"> <li>• Kept project up to date and made sure everyone was operating under current COVID-19 protocols as recommended by the CDC.</li> <li>• Attends and participates weekly project progress meetings with Marra Services and Walsh Construction for their phases of the project.</li> <li>• Involved in site safety communication and coordination with OMIDDD site representatives, project engineers, and consultants.</li> <li>• Observes and documents daily work to prevent critical safety issues from developing. If issues discovered contractors are updated to address moving forward.</li> <li>• Daily recap report provided for any daily incidents to prevent critical and reoccurring issues</li> <li>• Participated and helped to develop NESPS Safety Manual prepared by NTH Team.</li> <li>• Worked with contractors and team to develop weekly Job Safety Analysis for the work ahead to prevent injury, damage, and delay of the project.</li> <li>• Monitoring participating and potential contractors on site for required enrollment.</li> <li>• On site meeting with Lardner Elevator Corp regarding potential elevator installation for the wet well at the NESPS. The is a special Class I Div 1 equipment due to flammability/H2S corrosive atmosphere. This requires additional safety planning and oversight due to nature of work.</li> <li>• Involved in critical task changing out the knife gates with involves flow control. Worked with Walsh on process and toolbox talk around safety for changing knife gates. Ongoing process for knife gate swaps.</li> </ul>		

## Critical Loss Prevention Activities

- a. Marra was attempting to offload pallets of Channeline Pipe Sections upon arrival in Conex Trailer from Dubai UAE. Noted unsafe unloading, activity stopped, and Contractor implemented safe unloading method.
  - i. No method statement of Job Safety Analysis was performed prior to unloading. Upon OCIP Safety Director's discovery activity was halted. Material manufacturer was solicited for safe unloading practices to their material and specialized shipping pallet.
    - 1. Need to add potential impact if issue was not discovered resulting in injury or damage to pipe.
      - a. Potential life-threatening Injuries
      - b. Damage to Channeline pipe resulting in project delays. This specific material is very specialized and manufactured in Dubai. Damage to material of this nature requiring replacement would result significant delays if replacement material was needed causing project completion delay.
      - c. Damage to third party property (transportation carrier) which could result in potential OCIP liability claim to be made.



Closeout
<p>Current estimated completion dates:</p> <ul style="list-style-type: none"> <li>• Northeast Sewage Pump Station is first quarter 2023</li> <li>• North Interceptor - East Arm is first quarter 2023</li> </ul> <p>Estimated completion dates have been pushed back due to COVID-19 pandemic related supply chain issues. This has impacted both portions of the project to no fault of safety, engineering, or contractors.</p> <p>OCIP Safety Report will be reconciled quarterly moving forward and provided to the board on a semi-annual basis throughout project completion.</p>

Northeast Sewage Pump Station Project – Enrolled Contractors	
<ul style="list-style-type: none"> <li>• The Walsh Group</li> <li>• Gillett Excavating</li> <li>• John E. Greene Company</li> <li>• GPRS</li> <li>• CB, Inc.</li> <li>• FMG Saw Cutting Inc.</li> <li>• Union Caisson, Inc.</li> <li>• De-Cal, Inc.</li> <li>• Allied Ventilation, Inc.</li> <li>• Rival Insulation</li> <li>• D.C. Byers Company</li> <li>• Professional Engineering Associates, Inc.</li> <li>• Performance Environmental Services, Inc.</li> <li>• Doestch Environmental</li> <li>• Ventcon, Inc.</li> <li>• General Steel Erectors, Inc.</li> <li>• Comet Contracting, Inc.</li> <li>• Great Lakes Ceiling &amp; Carpentry, Inc.</li> <li>• Heritage &amp; Company Inc.</li> <li>• Process Control &amp; Instrumentation LLC</li> <li>• Industrial Fence and Landscaping, Inc.</li> <li>• Commercial Contracting Corporation</li> <li>• Innovated Energy Controls LLC</li> </ul>	<ul style="list-style-type: none"> <li>• Rotor Electric Company of Michigan, LLC</li> <li>• Christman Constructors, Inc.</li> <li>• Shaw Electric</li> <li>• Ideal Contracting, LLC</li> <li>• Quality Re-Steel</li> <li>• Cross Enterprise, Inc.</li> <li>• Nationwide Construction Group</li> <li>• Ram Construction Services</li> <li>• Signature Contracting Group, LLC</li> <li>• Leidal &amp; Hart Mason Contractors, Inc.</li> <li>• Great Lakes Dock &amp; Door LLC</li> <li>• Solid Platforms, Inc.</li> <li>• Elite Environmental</li> <li>• RJ Stacey LTD</li> <li>• Ross Structural Steel, Inc.</li> <li>• Blue Star, Inc.</li> <li>• Schreiber Corporation</li> <li>• Trane US Inc.</li> <li>• D/A Central Inc.</li> <li>• FRP Construction, LLC</li> <li>• Peterson Glass Company, Inc.</li> <li>• Detroit Diamond Drilling</li> <li>• Utilities Instrumentation Services, Inc.</li> </ul>

North Interceptor – East Arm Rehabilitation Project – Enrolled Contractors	
<ul style="list-style-type: none"> <li>• Marra Services, Inc.</li> <li>• State Barricades, Inc.</li> <li>• PK Contracting Inc.</li> <li>• Rotor Electric Company of Michigan, LLC</li> </ul>	<ul style="list-style-type: none"> <li>• Griffin Contract Dewatering LLC</li> <li>• FMG Concrete Cutting Inc.</li> <li>• Cascade Drilling L.P.</li> <li>• National Construction Rentals</li> </ul>

**Agenda Item No. 7**

Revised Budget and Flow Allocations for  
Rate Year 2022/2023



## Oakland-Macomb Interceptor Drain Drainage District

---

**TO:** Mike Gregg, Chairman  
Oakland-Macomb Interceptor Drain Drainage District (OMIDDD)

**FROM:** Raphael Chirolla; Financial Services OCWRC  
Bruce Manning, Financial Manager MCPWO

**SUBJECT:** Rate Year (RY) 2022/23 Revised Charges Recommendation

**DATE:** June 15, 2022

On June 2, 2022, the Great Lakes Water Authority approved the removal of the fiscal year 2023 Highland Park bad debt charges from the revenue requirements of the wholesale sewer customers. Attached is a revised operating budget for fiscal year 2023 reflecting this change.

**Recommended Action: Approve the proposed revised operating budget (Exhibit A) for the rate year beginning July 1, 2022, as presented.**

Effective July 1, 2022

# Exhibit A

## Annual Operating Charges

	Current 2022	2023	COSDS	MIDD	Annual		Monthly	
	Budget	Budget	%	%	COSDS	Macomb	COSDS	MIDD
<b>GLWA</b>								
Common-to-all and OMIDDD Charges	\$ 68,038,100	\$ 68,870,100	31.77%	68.23%	\$ 21,880,031	\$ 46,990,069		
CSO Program	1,671,700	1,692,300	39.48%	60.52%	668,120	1,024,180		
Total	69,709,800	70,562,400			22,548,151	48,014,249	\$ 1,879,012.58	\$ 4,001,187.42
<b>OMIDDD</b>								
Operations and Maintenance Expense								
Sewer System Maintenance	1,078,400	595,360	31.77%	68.23%	189,146	406,214		
Sewer System Engineering	52,210	68,220	31.77%	68.23%	21,673	46,547		
Pump Maintenance Unit	2,191,860	2,237,780	31.77%	68.23%	710,943	1,526,837		
Systems Control Unit	260	410	31.77%	68.23%	130	280		
Mapping Unit	2,070	1,300	31.77%	68.23%	413	887		
Miss Dig	360	110	31.77%	68.23%	35	75		
General and Administrative	63,090	1,261,030	31.77%	68.23%	400,629	860,401		
Subtotal	3,388,250	4,164,210			1,322,969	2,841,241	110,247.42	236,770.08
Non Operating	-	-	31.77%	68.23%	-	-	-	-
Major Maintenance	1,150,000	1,150,000	31.77%	68.23%	365,355	784,645	30,446.25	65,387.08
Emergency Maintenance	500,000	500,000	31.77%	68.23%	158,850	341,150	13,237.50	28,429.17
Capital Improvement	802,400	800,000	33.10%	66.90%	264,800	535,200	22,066.67	44,600.00
Subtotal	2,452,400	2,450,000			789,005	1,660,995		
O&M Non-Rate Revenue	(200,420)	(210,060)	31.77%	68.23%	(66,736)	(143,324)	(5,561.33)	(11,943.67)
<b>FY 2023 Total Fixed Charges</b>	<b>\$ 75,350,030</b>	<b>\$ 76,966,550</b>			<b>\$ 24,593,389</b>	<b>\$ 52,373,161</b>	<b>2,049,449.09</b>	<b>4,364,430.08</b>

Capital Improvements are defined as investments that are made to assets that exceed \$5,000 and increase the useful life of assets by five years or more.

Debt Service*		
2010A mfa 5368-02	1,671,500	1,673,875
2010B	-	-
2011A mfa 5368-02	1,624,750	1,619,688
2013A mfa 5368-03	3,954,400	3,953,400
2014A	468,344	471,844
2015A mfa 2001-01	543,625	544,250
2019 refunding	437,280	445,528
2019 revenue	1,069,018	507,315
2020A	3,278,650	3,273,900
2022 Issuance Projected Debt**	392,900	887,750
Total Debt Service	13,440,466	13,377,549
<b>Total OMIDDD Related Revenue Requirements</b>	<b>88,790,496</b>	<b>90,344,099</b>

\* Estimated annual debt service for the 2023 budget updated February 2022

\*\* 2022 issuance projected debt for 2023 using dated date of 9/1/2022, funding of approximately \$15 million, final maturity 7/1/2042, and true interest cost of approximately 2.6%.

## **Agenda Item No. 8**

Change Order





## Oakland-Macomb Interceptor Drain Drainage District

**TO:** Michael Gregg, Chairperson  
Oakland-Macomb Interceptor Drain Drainage Board

**FROM:** Joel Brown, P.E. Oakland County Water Resources Commissioner's Office  
Stephen Downing Macomb County Public Works Commissioner's Office

**SUBJECT:** Approval of Service Maintenance Contract Change Orders to Extend Contract Time and Contract Amounts Between OMIDDD and Various Contractors for the NESPS and OMID System

**DATE:** June 15, 2022

Per "Amendment #1 to the Wastewater Disposal Contract Between the Great Lakes Water Authority, As Assignee of the City of Detroit, and the Oakland-Macomb Interceptor Drainage District," the OMIDDD assumed control of the maintenance responsibilities for the Northeast Sewage Pumping Station and the North Interceptor-East-Arm on July 1, 2019. On June 19, 2019, the OMIDDD Board approved several maintenance contracts with contractors to supply routine repair and preventative maintenance as well as emergency response and troubleshooting services for equipment both at the NESPS but also on the OMID system as a whole. These contracts are set to expire at the end of June 2022. In addition, a few contracts have expended the majority of their existing contract amounts as shown in Table 1:

Table 1. OMIDDD Maintenance Contract Amounts, Amounts Expensed and Amounts Remaining

Vendor	Contract Number	Available Amount	Amount Expensed	Amount Remaining
Rotor Electric	5807/CON8629	\$1,000,000	\$1,000,000	\$0.00
CSM Mechanical	5817/CON8637	\$711,976.61	\$350,389.66	\$361,586.95
HESCO/Hamlett	5819/CON8638	\$1,000,000	\$154,956.11	\$845,043.89
Konecranes	5820/CON8639	\$500,000	\$150,005.53	\$349,994.47
PM Technologies	5821/CON8640	\$500,000	\$342,991.64	\$158,825.86
Kennedy Industries	5825/CON8643	\$1,000,000	\$141,876.35	\$858,123.65

Consequently, change orders have been developed between OMIDDD and the above contractors to extend the contract time (between 1 and 3 years) and increase the contract amount for various equipment/services. In addition, where applicable, the change orders include new quotes and rates submitted by the contractors for the contract time extension and are generally in line with current price escalation. The contracts are recommended to be extended due to the contractors' familiarity with the NESPS and OMID equipment and exemplary service provided over the last three years. Where the

majority of the existing contract amounts have been expended, a not to exceed (NTE) contract amount increase has also been added to the change order. A summary of the change orders for each contract is as follows:

**1. Rotor Electric Company of Michigan (\$1,000,000 NTE increase and 3-year extension):**

Responsible for maintaining motors, variable frequency drives, switchgear, transformers, relays, circuit breakers and instrumentation as well as associated wiring and appurtenances.

**2. CSM Mechanical (\$500,000 NTE and 3-year extension):**

Responsible for maintaining local water and sewer conveyance piping, including valves, fittings as well as other mechanical systems.

**3. HESCO (3-year extension):**

Responsible for maintaining the control structure primary/ secondary sluice gates and NESPS knife gates as well as and associated hydraulic/actuating components.

**4. Konecranes (1-year extension):**

Responsible for maintaining dry well and wet well overhead cranes.

**5. Preventive Maintenance Technologies (\$500,000 NTE and 3-year extension):**

Responsible for maintaining the NESPS onsite generators.

**6. Kennedy Industries (3-year extension):**

Responsible for maintaining pumps and associated appurtenances

Please note that the Board also approved a contract with Detroit Elevator Company also on June 19, 2019. This contract is not set to expire until August 1, 2022 and will be addressed at next month's Board meeting.

**RECOMMENDED ACTION: Approve the attached change orders to the maintenance contracts for the above vendors to extend the contract time and increase the contract funding where applicable for OMIDDD and the NESPS maintenance services.**

**CHANGE ORDER NO. 1**

Oakland-Macomb Interceptor Drain Drainage District Board  
 For Extension of OMIDDDD-Rotor Maintenance Services Contract #5807  
 Located in Macomb and Wayne County, MI

CONTRACTOR: Rotor Electric Company of Michigan, LLC  
 Address: 9522 Grinnell  
Detroit, MI 48213

Authorization for Changes In and Extras to Contract

Change Order No: 1 Date: 6/3/2022

Auth No.	Location-Description-Reason	Unit Used	Est. Qty.	Unit Price	Amount Increase	Amount Decrease
1-1	<b><u>LOCATION:</u></b> OMID Contol Structures and NESPS					
	<b><u>DESCRIPTION:</u></b>  <b>(Change/Add):</b>					
1-1	This change order extends the existing contract #5807 another three years to June 28, 2025 for Rotor to continue to provide preventive, corrective and emergency electrical maintenance on OMID Control Structure and NESPS Equipment in accordance with the appended proposal and pricing dated May 24, 2022. An additional \$1,000,000 is to be added to the contract to facilitate payment for services rendered.	Years	3	N/A	3 Years	-
		NTE	1	\$1,000,000	\$1,000,000	
1-1	<b><u>REASON:</u></b> OMIDDDD is in need of continued preventive, corrective and emergency electrical maintenance services to ensure efficient and effective operation of the OMID Flow Control Structures and NESPS. Rotor has provided these services at an exceptional level over the past three years. In addition, they are subcontractor to Walsh on the NESPS Pumping and Electrical Upgrades Project and are thus will be very familiar with the new equipment being installed, making them well-suited to provide maintenace services into the future					
				Item A Total	\$1,000,000	\$0.00
				Total	\$1,000,000	

Change Order

**CHANGE ORDER NO. 1**

Oakland-Macomb Interceptor Drain Drainage District Board  
For Extension of OMIDDDD-Rotor Maintenance Services Contract #5807

Prepared by: \_\_\_\_\_ Date: \_\_\_\_\_  
WRC: Joel Brown, P.E., Chief Engineer

Approved by: \_\_\_\_\_ Date: \_\_\_\_\_  
MCPWO Manager: Stephen Downing (Construction & Maintenance Manager)

Approved by: \_\_\_\_\_ Date: \_\_\_\_\_  
WRC Manager: Sid Lockhart, P.E. (Special Projects Manager)

Approved by: \_\_\_\_\_ Date: \_\_\_\_\_  
WRC Manager – Steven Korth, P.E.

The Contractor agrees to do the work described above and agrees to accept payment in full on the basis indicated.

Accepted by: \_\_\_\_\_ Date: \_\_\_\_\_  
Title

of: Rotor Electric Company of Michigan, LLC

The Contractor is hereby authorized and instructed to do the work described above in accordance with the terms of the Contract.

This Change Order No. 1 was approved by the Drainage Board on: \_\_\_\_\_ Date: \_\_\_\_\_

**CHANGE ORDER NO. 2**

Oakland-Macomb Interceptor Drain Drainage District Board  
 For Extension of OMIDDDD-CSM Mechanical Maintenance Services Contract #5817  
 Located in Macomb and Wayne County, MI

CONTRACTOR: CSM Mechanical, LLC  
 Address: 1235 Holden Ave.  
 Milford, MI 48381

Authorization for Changes In and Extras to Contract  
 Change Order No: 2 Date: 6/3/2022

Auth No.	Location-Description-Reason	Unit Used	Est. Qty.	Unit Price	Amount Increase	Amount Decrease	
2-1	<b>LOCATION:</b> OMID Contol Structures and NESPS						
2-1	<b>DESCRIPTION:</b> <b>(Change/Add):</b> This change order extends the existing contract #5817 another three years to June 28, 2025 for CSM to continue to provide preventive, corrective and emergency electrical maintenance on OMID Control Structure and NESPS Equipment in accordance with the appended pricing dated May 3, 2022. An additional \$500,000 is to be added to the contract to facilitate pavment for services rendered.	Years	3	N/A	3 Years	-	
2-1	<b>REASON:</b> OMIDDDD is in need of continued preventive, corrective and emergency mechanical maintenance services to ensure efficient and effective operation of the OMID Flow Control Structures and NESPS. CSM has provided these services at an exemplary level over the past three years. In addition, they were the prime contractor for the NESPS Odor and Corrosion Control Project and are thus very familiar with its mechanical operation.	NTE	1	\$500,000	\$500,000		
					Item A Total	\$500,000	\$0.00
					Total	\$500,000	

Change Order

**CHANGE ORDER NO. 2**

Oakland-Macomb Interceptor Drain Drainage District Board  
For Extension of OMIDDDD-CSM Maintenance Services Contract #5817

Prepared by: \_\_\_\_\_ Date: \_\_\_\_\_  
WRC: Joel Brown, P.E., Chief Engineer

Approved by: \_\_\_\_\_ Date: \_\_\_\_\_  
MCPWO Manager: Stephen Downing (Construction & Maintenance Manager)

Approved by: \_\_\_\_\_ Date: \_\_\_\_\_  
WRC Manager: Sid Lockhart, P.E. (Special Projects Manager)

Approved by: \_\_\_\_\_ Date: \_\_\_\_\_  
WRC Manager – Steven Korth, P.E.

The Contractor agrees to do the work described above and agrees to accept payment in full on the basis indicated.

Accepted by: \_\_\_\_\_ Date: \_\_\_\_\_  
Title

of: CSM Mechanical, LLC

The Contractor is hereby authorized and instructed to do the work described above in accordance with the terms of the Contract.

This Change Order No. 1 was approved by the Drainage Board on: \_\_\_\_\_ Date: \_\_\_\_\_

**CHANGE ORDER NO. 1**

Oakland-Macomb Interceptor Drain Drainage District Board  
 For Extension of OMIDDDD-HESCO Mechanical Maintenance Services Contract #5819  
 Located in Macomb and Wayne County, MI

CONTRACTOR: HESCO  
 Address: 29770 Hudson Dr.  
Novi, MI 48377

Authorization for Changes In and Extras to Contract

Change Order No: 1 Date: 6/3/2022

Auth No.	Location-Description-Reason	Unit Used	Est. Qty.	Unit Price	Amount Increase	Amount Decrease
	<b><u>LOCATION:</u></b>					
1-1	OMID Contol Structures and NESPS					
	<b><u>DESCRIPTION:</u></b>					
	<b>(Change/Add):</b>					
1-1	This change order extends the existing contract #5819 another three years to June 30, 2025 for HESCO to continue to provide preventive, corrective and emergency hydraulic/instrumentation maintenance on OMID Control Structure and NESPS Equipment in accordance with the appended proposal and pricing dated June 1, 2022. An increase to the contract amount is not needed at this time	Years	3	N/A	3 Years	-
	<b><u>REASON:</u></b>					
1-1	OMIDDDD is in need of continued preventive, corrective and emergency hydraulic and instrumentation maintenance services to ensure efficient and effective operation of the OMID Flow Control Structures and NESPS. HESCO has provided these services at an exemplary level over the past three years and is also the gate valve vendor on the NESPS Pumping and Electrical Upgrades Project.					
				Item A Total	\$0.00	\$0.00
				Total	\$0.00	

Change Order

**CHANGE ORDER NO. 1**

Oakland-Macomb Interceptor Drain Drainage District Board  
For Extension of OMIDDDD-HESCO Maintenance Services Contract #5819

Prepared by: \_\_\_\_\_ Date: \_\_\_\_\_  
WRC: Joel Brown, P.E., Chief Engineer

Approved by: \_\_\_\_\_ Date: \_\_\_\_\_  
MCPWO Manager: Stephen Downing (Construction & Maintenance Manager)

Approved by: \_\_\_\_\_ Date: \_\_\_\_\_  
WRC Manager: Sid Lockhart, P.E. (Special Projects Manager)

Approved by: \_\_\_\_\_ Date: \_\_\_\_\_  
WRC Manager – Steven Korth, P.E.

The Contractor agrees to do the work described above and agrees to accept payment in full on the basis indicated.

Accepted by: \_\_\_\_\_ Date: \_\_\_\_\_  
Title

of: HESCO

The Contractor is hereby authorized and instructed to do the work described above in accordance with the terms of the Contract.

This Change Order No. 1 was approved by the Drainage Board on: \_\_\_\_\_ Date: \_\_\_\_\_



**CHANGE ORDER NO. 1**

Oakland-Macomb Interceptor Drain Drainage District Board  
 For Extension of OMIDDDD-Konecranes Maintenance Services Contract #5820  
 Located in Macomb and Wayne County, MI

CONTRACTOR: Konecranes, Inc.  
 Address: 42970 West 10 Mile Road  
Novi, MI 48375

Authorization for Changes In and Extras to Contract  
 Change Order No: 1 Date: 6/3/2022

Auth No.	Location-Description-Reason	Unit Used	Est. Qty.	Unit Price	Amount Increase	Amount Decrease	
1-1	<b><u>LOCATION:</u></b> NESPS						
1-1	<b><u>DESCRIPTION:</u></b> <b>(Change/Add):</b> This change order extends the existing contract #5820 another year to June 28, 2023 for Konecranes to continue to provide preventive, corrective and emergency crane maintenance on the NESPS cranes in accordance with lump sum quotes and the appended rate schedule dated June 10, 2022. No additional funding is needed at this time.	Years	1	N/A	1 Year	-	
1-1	<b><u>REASON:</u></b> OMIDDDD is in need of continued preventive, corrective and emergency crane maintenance services to ensure efficient and effective operation of the NESPS indoor and outdoor cranes. Due to the criticality of the cranes for onsite project use, and Konecranes familiarity with them, Konecranes should continue to provide these services while the NESPS Pumping and Electrical Upgrades Project is ongoing.						
					Item A Total	\$0.00	\$0.00
					Total	\$0.00	

Change Order

**CHANGE ORDER NO. 1**

Oakland-Macomb Interceptor Drain Drainage District Board  
For Extension of OMIDDDD-Konecranes Maintenance Services Contract #5820

Prepared by: \_\_\_\_\_ Date: \_\_\_\_\_  
WRC: Joel Brown, P.E., Chief Engineer

Approved by: \_\_\_\_\_ Date: \_\_\_\_\_  
MCPWO Manager: Stephen Downing (Construction & Maintenance Manager)

Approved by: \_\_\_\_\_ Date: \_\_\_\_\_  
WRC Manager: Sid Lockhart, P.E. (Special Projects Manager)

Approved by: \_\_\_\_\_ Date: \_\_\_\_\_  
WRC Manager – Steven Korth, P.E.

The Contractor agrees to do the work described above and agrees to accept payment in full on the basis indicated.

Accepted by: \_\_\_\_\_ Date: \_\_\_\_\_  
Title

of: Konecranes, Inc.

The Contractor is hereby authorized and instructed to do the work described above in accordance with the terms of the Contract.

This Change Order No. 1 was approved by the Drainage Board on: \_\_\_\_\_ Date: \_\_\_\_\_

**CHANGE ORDER NO. 1**

Oakland-Macomb Interceptor Drain Drainage District Board  
 For Extension of OMIDDDD-PM Technologies Maintenance Services Contract #5821  
 Located in Macomb and Wayne County, MI

CONTRACTOR: Preventive Maintenance Technologies, LLC  
 Address: 28294 Beck Rd  
Wixom, MI 48393

Authorization for Changes In and Extras to Contract  
 Change Order No: 1 Date: 6/3/2022

Auth No.	Location-Description-Reason	Unit Used	Est. Qty.	Unit Price	Amount Increase	Amount Decrease
1-1	<b>LOCATION:</b> NESPS					
1-1	<b>DESCRIPTION:</b> <b>(Change/Add):</b> This change order extends the existing contract #5821 another three years to June 28, 2025 for PM Technologies to continue to provide preventive, corrective and emergency generator maintenance at the NESPS in accordance with the appended proposals and rate sheet dated June 4, 2022. An additional \$500,000 is to be added to the contract to facilitate payment for services rendered.	Years	3	N/A	3 Years	-
1-1	<b>REASON:</b> OMIDDDD is in need of continued preventive, corrective and emergency generator maintenance services to ensure efficient and effective operation of the NESPS generators. PM Technologies has provided these services at an exemplary level over the past three years and are very familiar with the equipment.	NTE	1	\$500,000	\$500,000	-
				Item A Total	\$500,000	\$0.00
				Total	\$500,000	

Change Order

**CHANGE ORDER NO. 1**

Oakland-Macomb Interceptor Drain Drainage District Board  
For Extension of OMIDDDD-PM Technologies Maintenance Services Contract #5821

Prepared by: \_\_\_\_\_ Date: \_\_\_\_\_  
WRC: Joel Brown, P.E., Chief Engineer

Approved by: \_\_\_\_\_ Date: \_\_\_\_\_  
MCPWO Manager: Stephen Downing (Construction & Maintenance Manager)

Approved by: \_\_\_\_\_ Date: \_\_\_\_\_  
WRC Manager: Sid Lockhart, P.E. (Special Projects Manager)

Approved by: \_\_\_\_\_ Date: \_\_\_\_\_  
WRC Manager – Steven Korth, P.E.

The Contractor agrees to do the work described above and agrees to accept payment in full on the basis indicated.



Accepted by: Strategic Account Manager Date: 6.8.2022  
Title

of: PM Technologies, LLC

The Contractor is hereby authorized and instructed to do the work described above in accordance with the terms of the Contract.

This Change Order No. 1 was approved by the Drainage Board on: \_\_\_\_\_ Date: \_\_\_\_\_

**CHANGE ORDER NO. 1**

Oakland-Macomb Interceptor Drain Drainage District Board  
 For Extension of OMIDDDDD-Kennedy Mechanical Maintenance Services Contract #5825  
 Located in Macomb and Wayne County, MI

CONTRACTOR: Kennedy Industries, Inc.  
 Address: 4925 Holtz Dr.  
Wixom, MI 48393

Authorization for Changes In and Extras to Contract  
 Change Order No: 1 Date: 6/3/2022

Auth No.	Location-Description-Reason	Unit Used	Est Qty	Unit Price	Amount Increase	Amount Decrease
1-1	<b><u>LOCATION:</u></b> OMID Contol Structures and NESPS					
1-1	<b><u>DESCRIPTION:</u></b> <b>(Change/Add):</b> This change order extends the existing contract #5825 another three years to June 30, 2025 for Kennedy to continue to provide preventive, corrective and emergency pump maintenance on OMID Control Structure 6 and NESPS Equipment in accordance with the attached pricing. An increase in the contract amount is not needed at this time.	Years	3	N/A	3 Years	-
1-1	<b><u>REASON:</u></b> OMIDDD is in need of continued preventive, corrective and emergency pump maintenance services to ensure efficient and effective operation of the OMID Flow Control Structures and NESPS. Kennedy has provided these services at an exemplary level over the past three years and is intimately familiar with the					
				Item A Total	\$0.00	\$0.00
				Total	\$0.00	

Change Order

**CHANGE ORDER NO. 1**

Oakland-Macomb Interceptor Drain Drainage District Board  
For Extension of OMIDDDD-Kennedy Maintenance Services Contract #5825

Prepared by: \_\_\_\_\_ Date: \_\_\_\_\_  
WRC: Joel Brown, P.E., Chief Engineer

Approved by: \_\_\_\_\_ Date: \_\_\_\_\_  
MCPWO Manager: Stephen Downing (Construction & Maintenance Manager)

Approved by: \_\_\_\_\_ Date: \_\_\_\_\_  
WRC Manager: Sid Lockhart, P.E. (Special Projects Manager)

Approved by: \_\_\_\_\_ Date: \_\_\_\_\_  
WRC Manager – Steven Korth, P.E.

The Contractor agrees to do the work described above and agrees to accept payment in full on the basis indicated.

Accepted by: \_\_\_\_\_ Date: \_\_\_\_\_  
Title

of: Kennedy Industries, Inc.

The Contractor is hereby authorized and instructed to do the work described above in accordance with the terms of the Contract.

This Change Order No. 1 was approved by the Drainage Board on: \_\_\_\_\_ Date: \_\_\_\_\_

**CHANGE ORDER NO. TWENTY-THREE**

Oakland Macomb Interceptor Drain, Drainage District (OMIDDD)

For Construction of the Pump and Electrical Upgrades Project

Northeast Sewage Pumping Station (NESPS)

Located in the City of Detroit, Wayne County, Michigan

**CONSTRUCTION MANAGER,  
AT RISK (CMAR)  
Walsh Construction Co. II, LLC**

**Authorization for:**

- 1.) Installation of Elevator Night Light Circuits; 2.)  
Remove existing elevator equipment and install new  
Wet Well Personnel Elevator

\*\*\*\*\*

Address:

Walsh Construction Co. II LLC  
3031 West Grand Blvd., Suite 640  
Detroit, MI 48202

Change Order No. 23 Date: June 03, 2022

	Location-Description-Reason	Unit	Est. Quant.	Unit Price	Amount Increase	Amount Decrease
23 -1	<p><b><u>LOCATION:</u></b></p> <p>The Northeast Sewage Pumping Station; Detroit, Wayne County, Michigan</p> <hr/> <p><b><u>DESCRIPTION (Extra/ Add):</u></b></p> <p>Re-circuit the building interior lighting system to ensure that the Dry Well Elevator lobby lights remain continuously in operation (24x7).</p> <p><b><u>REASON:</u></b></p> <p>The City of Detroit Elevator Field Inspector has interpreted the Detroit Elevator Code to require continuous elevator lobby illumination for safety ingress/ egress purposes. This task required that certain elevated electrical circuits be revised from normal on/ off wiring to "always on" to ensure power to selected elevator light fixtures remains uninterrupted.</p> <p>Attachment: Walsh Construction PCI # 970141</p>	LS	1 ea.	\$13,602.62	\$13,602.62	-0-

OMID DD NESPS; Pump & Electrical Upgrades Project; C.O. # 23

	Location-Description-Reason	Unit	Est. Quant.	Unit Price	Amount Increase	Amount Decrease
23 -2	<p><b>DESCRIPTION (Extra/ Add):</b></p> <p>Demolish the existing (non-functioning) Wet Well Personnel Elevator and install a new re-designed replacement elevator (Note: This task represents the initial phase of the Wet Well elevator replacement project, and will be supplemented by additional subordinate work as determined necessary following final design parameters).</p> <p><b>REASON:</b></p> <p>The original NESPS facility included an operating personnel elevator intended to transport a minimal size crew from the ground surface entrance down to the Wet Well "mezzanine" level for maintenance and inspection purposes. The existing elevator has experienced long periods of poor maintenance protocols and has been inoperable for a significant time period. The condition of the original installation is now considered irreparable, and therefore, requires a complete removal and replacement utilizing new equipment that fully satisfies current Elevator Code and inspection guidelines.</p> <p>Noted also is the fact that due to the elevator location being entirely within the Wet Well with constant exposure to wastewater atmosphere, the design requirements specify all structural components (including accessory items) to consist of Cl. 316L stainless steel, and all electrical components to satisfy the demanding Class I, Division 1 Code (Hazardous Atmosphere) requirements.</p> <p>The detailed design of the new elevator equipment (included in this initial phase) will, to a significant extent, be premised on a forensic evaluation of the existing elevator installation in order to determine dimensional requirements, cab operating characteristics, machine room equipment layout, and elevator "pit" flooding mitigation, all of which are requirements for the new elevator operation.</p>	LS	ea.	\$864,652.19	\$864,652.19	-0-



**OMID DD NESPS; Pump & Electrical Upgrades Project; C.O. # 23**

	Location-Description-Reason	Unit	Est. Quant.	Unit Price	Amount Increase	Amount Decrease
23 -2	<p>With the extended "out of service" condition of the existing elevator, NESPS personnel are currently required to access the wet well bar screen area using the existing stairway arrangement consisting of a continuous vertical climb of 91' with 136 individual stair steps.</p> <p>Accordingly, for reasons of worker safety, proper maintenance of wet well bar screens and level sensor equipment, and routine access to incoming wastewater flows for sampling and heavy debris removal, replacement of the NESPS Elevator # 2 (Wet Well) is considered a necessary upgrade to the overall station.</p> <p><i>(As noted previously, additional work tasks involving electrical power supply, interior painting and coating, mechanical details, and various code requirements will be identified and addressed in a subsequent Change Order.)</i></p> <p>Attachment: Walsh Construction PCI No. 970143</p> <p align="center">*****</p> <p><b>End of Change Order No. 23 Line Items</b></p>					
	Summary, Change Order # 23 Line Items				Amount Increase	Amount Decrease
				Totals	\$878,254.81	-0-
				Net Changes (Increase)	\$878,254.81	-----

OMID DD NESPS; Pump & Electrical Upgrades Project; C.O. # 23

Prepared By:  
Lawrence T. Gilbert, P.E.  
NTH Consultants, Ltd.



Date: 6-02-2022

Recommended By:  
John Michalski, P.E.  
Engineer of Design, Applied Science, Inc.



Date: 6/6/2022

Approved By:  
Joel Brown, P.E.  
Project Manager, WRC

\_\_\_\_\_

Date: \_\_\_\_\_

Approved By:  
Stephen Downing  
Construction and Maintenance Manager, Macomb County Public Works

\_\_\_\_\_

Date: \_\_\_\_\_

Approved By:  
Sid Lockhart, P.E.  
Manager of Special Projects, WRC

\_\_\_\_\_

Date: \_\_\_\_\_

Approved by:  
Steve Korth, P.E.  
Manager, WRC

\_\_\_\_\_

Date: \_\_\_\_\_

All of Construction Manager's contractual obligations remain in place and are applicable to all work and payments identified herein. No adjustment to contract time or price shall be made for these issues except as set out in this, or by a subsequent related, Change Order.

The Construction Manager agrees to do the work described above and agrees to accept Contract time adjustments in full on the basis indicated.

Accepted by: \_\_\_\_\_ Date \_\_\_\_\_  
Title

of: Walsh Construction Co. II, Inc.

The Construction Manager is hereby authorized and instructed to do the Work described above in accordance with the terms of the Contract, as amended.

This Change Order No. 23 was approved by the Drainage Board on: \_\_\_\_\_ Date: \_\_\_\_\_  
Page 4 of 5

\_\_\_\_\_

## Attachment No. 1 to Change Order No. Twenty-Three

The Engineer has reviewed the items included in this Change Order and confirms that these adjustments to the Contract are reasonable and in accordance with industry standards and the requirements of the Contract.

*Contract Status Summary*  
Change Order No. Twenty-Three  
OMID NESPS Pump & Electrical Upgrades Project

*Construction Manager at Risk: Walsh Construction Co. II*

Project Award Date (Pre-Construction Services)	December 16, 2019
Notice to Proceed Date (Construction Phase)	October 23, 2020
Contract Substantial Completion Date	March 24, 2023
Contract Final Completion Date	June 23, 2023
Original GMP Contract Value (Including Control Structure 9)	\$ 42,863,185.19
Pre-Construction Phase, Unused Budget	\$ 70,196.70
C.O. Values, # 7, 8, 9, 10, 11, 12, 13, 14, 15,16, 17,18, 19, 20, 21, and # 22 ( <u>Not Including</u> CS-9 C.O. total of \$ 63,100.29)	\$ 2,313,259.95
Change Order Value, this C.O. # 23	\$ 878,254.81
<b><i>Adjusted GMP Contract Value (incl. this C.O. # 23)</i></b>	<b>\$ 46,124,896.65</b>

**Agenda Item No. 9**

Construction Estimates

**OAKLAND MACOMB INTERCEPTOR DRAIN DRAINAGE BOARD**  
**Northeast Sewage Pumping Station- Pump and Electrical Upgrades Project**  
**Located in the City of Detroit, Wayne County, Michigan**

**Regular Construction Estimate No. Twenty**  
**Page One of Two**

**May 01, 2022 through May 30, 2022**

Department No.:	6010101	Account No.:	731472
Fund No.:	84917	Program No.:	149015
Project No.:	1-3309	Activity:	FAC

**Construction Manager at Risk:** Vendor # 23191 LI 43331; exp. 12/16/22  
Walsh Construction Co. Date of Contract: Dec. 16, 2019  
3031 West Grand Boulevard, Suite 640 (Adjusted) Final Completion Date: July 28, 2023  
Detroit, MI 48202 Contract No. 5977

---

Orig. GMP amount for Pump & Elec. Upgrades Project, not including CS-9 and Pre-Const. Balance	\$44,107,745.18
Expended Pre-Construction Phase Amount	(\$1,174,363.30)
<i>Unused Pre-Construction Phase Budget</i>	(\$70,196.70)
<i>CS-9 Budget from GMP</i>	(\$3,251,117.72)
NESPS Pump & Elec. Upgrades Original Contract Budget	\$39,612,067.46
Change Orders, This Estimate: C.O. No. 22	\$49,846.33
Previous C.O.s: (C.O.# 7, 8, 9, 10, 11,12, 13, 14, 15, 16, 17, 18, 19, 29 and 21)- <i>Corrected Value</i>	\$2,263,413.62
Unused Pre-Construction Phase Budget	\$70,196.70
<b>Adjusted Construction Contract Amount: ( N/I CS-9)</b>	<b>\$41,995,524.11</b>
<hr/>	
Sub-Total To Date: (CS-9 Costs are Not included on this Estimate)	\$23,535,546.28
Less Deductions:	None
Gross Estimate: (Work in Place) Value Complete = 56.0 %	\$23,535,546.28
Less Amount Reserved (Incl. Partial Subcon. Reductions - See Schedule)	\$2,142,956.15
Total Amount Allowed To Date:	\$21,392,590.13
Less Previous Estimates:	\$20,535,057.81
Current Payment Due	\$857,532.32
Reserve Pay to Contractor:	\$0.00
Balance to Finish: \$18,459,974.83	Accounting Auditor:
<hr/>	
Amount To Be Reserved (From Above): )	\$2,142,956.15
Less Previous Transfers To Reserve (N/I CS-9 Contract Retention)	(\$2,138,902.33)
<b>Amount of Current Transfer</b>	<b>\$4,053.82</b>

OAKLAND MACOMB INTERCEPTOR DRAIN DRAINAGE BOARD  
Northeast Sewage Pumping Station- Pump and Electrical Upgrades Project  
Located in the City of Detroit, Wayne County, Michigan  
Walsh Construction Co. II; Construction Manager at Risk

Regular Construction Estimate No. Twenty  
Page Two of Two

5/01/ 2022 through 5/30/ 2022

Prepared by:



Date:

06-06-2022

Lawrence T. Gilbert, P.E.; NTH Consultants Ltd.

Recommended by:



Date:

6/6/2022

John Michalski, P.E., ASI

Recommended by:

\_\_\_\_\_

Date:

\_\_\_\_\_

Joel Brown, P.E. Oakland County WRC

Recommended by:

Stephen Downing

Date:

6/10/2022

Stephen Downing; Macomb County OPWC

Approved for Payment by:

\_\_\_\_\_

Date:

\_\_\_\_\_

Sid Lockhart, P.E.; Special Projects Manager, Oakland County WRC

Regular Construction Estimate No. 20 (May, 2022)

Approved By Board On:

\_\_\_\_\_

**OAKLAND MACOMB INTERCEPTOR DRAIN DRAINAGE BOARD**  
**For Construction of the NI-EA OMID Contract 1 - PCI 4 Rehabilitation**  
**Located in the City of Detroit, Wayne, Michigan**  
**Project ID 1-00000003308**

Regular Construction Estimate No. 15

Period: 5/01/22 through 5/31/22

Department No.:	6010101	Account No.:	731472
Fund No.:	84917	Program No.:	149015
Project No.:	100000003308	Activity:	FAC

Contractor:	Vendor # 29656 Contract # 6323
Marra Services, Inc.	LI # 44838 exp. 1/20/23
700 E. 73 rd. Street	Date of Contract: January 21, 2021
Cleveland, OH 44103	Final Completion Date: September 9, 2022

Original Construction Contract Amount	\$14,732,510.00
Previous Change Orders: No. One and Two	\$808,198.88
Change Orders This Estimate: None	\$0.00
Total Net Change Orders:	\$808,198.88
<u>Adjusted Contract Amount:</u>	<u>\$15,540,708.88</u>
Sub-Total To Date	\$8,959,332.46
Less Deductions: None	\$0.00
Gross Estimate, Work in Place (57.65 % Complete)	\$8,959,332.46
Less Amount Reserved (Max. at 10% of 50% C.V.)	\$777,035.44
Total Amount Allowed To Date:	\$8,182,297.02
Less Previous Estimates	\$7,998,106.14
Net Payment Request To Be Paid To Contractor:	\$184,190.88
Reserve Payment to Contractor:	\$0.00
Balance to Finish: \$6,581,376.42	Accounting Auditor:
Amount to be Reserved from Above	\$777,035.44
Less Previous Transfers To Reserve:	\$777,035.44
Amount of Current Transfer	\$0.00

Prepared by:   
 Lawrence T. Gilbert, P.E.; NTH Consultants Ltd.

Date: 06-06-2022

Recommended by:   
 Saju Sachidanandan, P. E.; NTH Consultants Ltd.

Date: 06-06-2022

Recommended by: \_\_\_\_\_  
 Joel Brown, P.E. Oakland County WRC

Date: \_\_\_\_\_

Recommended by:   
 Stephen Downing; Macomb County OPWC

Date: 6/10/2022

Approved for Payment by: \_\_\_\_\_  
 Sid Lockhart, P.E.; Special Projects Manager, Oakland County WRC

Date: \_\_\_\_\_

**Agenda Item No. 10**

Report/Update – Status of OMID  
Project, Segments 1 through 4, NESPS,  
NI-EA



# Oakland Macomb Interceptor Drain (OMID) Repairs

## Project Progress Update

Prepared by:

F. Klingler, P.E., N. Kacynski, P.E., FK Engineering Assoc.  
S. Sachidanandan, P.E., L. Gilbert, P.E., NTH Consultants, Ltd.  
J. Michalski, P.E., Applied Science, Inc.; T. Moore, Metco Services, Inc.  
J. Matteo, P.E., Jacobs Engineering, Inc.

## June 15, 2022 OMIDDD Board Meeting

---

The following provides a status update as of the writing of this report (June 6, 2022) for the work completed for the Oakland-Macomb Interceptor Drain Repair Program (SRF Segments 1-4; Contract 7 PCI-4 repairs; Maintenance Repairs in PCI-5 through PCI-11A; Control Structure Modifications; NIEA Repairs; NESPS Upgrades; Odor/ Corrosion Control System, and other related work):

### SRF Segment 1 Status:

#### Contracts 1&2: Complete

#### System-wide Odor/Corrosion Study

##### Project Budget Summary (including EWOs):

• Adjusted Project Budget (including EWOs and Fan Testing Allowance):	\$567,447.00
• Total Spent (through May 2021):	\$566,441.58
• Additional Data Gathering Budget (under NTH):	\$84,926.00
• Additional Data Gathering Expenditure to date:	\$1,282.00

##### Status of Major Project Tasks:

- System-wide Odor/Corrosion Study and additional requested work under Jacobs Engineering is substantially complete. Jacobs delivered on May 28, 2021 a draft technical memorandum that summarizes the NI-EA Phase 1 odor sampling performed at the NESPS and in PCI-4. The initial contract was extended to 5/15/2022. This initial work will be completed under a new contract (NTH Contract #2603), under which Jacobs is currently performing additional data gathering (H2S and pressure readings) within the NIEA and OMID portions of the system to further evaluate impacts from flow control sequencing. Final Report will be updated to reflect the new data.

### SRF Segment 2 Status:

#### Contract 3 (Base Contract & C.O. 2E-2J): Complete

### SRF Segment 3 Status:

#### Contract 4: Complete

## June 15, 2022 OMIDDD Board Meeting

---

### **SRF Segment 4 Status:**

#### **Contract 5A/5B: Complete**

- City of Utica Use Agreement for access paths is pending; awaiting final authorization.

#### **Contract 6: Complete**

#### **Contract 7 (NIEA 110 feet of Emergency Rehab) – Complete**

Deterioration was noted in early 2021; also see NIEA Contract 1 Summary. Following several manned inspections, report from the manufacturer's representatives has now been received and reviewed by the Engineering Team. Final conclusions remain pending; however, the consensus of the engineering team is that this lining material may not be appropriate in the extreme H<sub>2</sub>S concentrations experienced at the Gatehouse location, and potentially other atypical locations in the interceptor. This initial section of PCI-4 is currently planned for re-lining (using GFRPMP) under NIEA OMID Contract 1 (PCI-4 Rehabilitation).

#### **NESPS Odor/Corrosion Control System (No Segment or Contract No.): Construction Complete**

#### **NESPS & OMID Maintenance, Operations & Upgrades Status:**

##### **Status of Emergency Contingency Plan for pumping during total power loss or other catastrophic system failure:**

- Mersino Dewatering is under contract for standby emergency bypass pumping.
- The OMIDDD Project Team is currently finalizing design for an approach for keeping the 15 Mile Road bypass pumping arrangement (initially constructed in summer 2021) intact. Plans are now in place for the existing bypass piping remaining on site as a proposed below grade installation pending final agreement with ITC.
- Remaining items in the final emergency plan include punch-list and optimization steps for electrification, the modification of one manhole, modifications at the 15-Mile Road Site, and overall optimization of the Emergency Plan per above.

##### **Additional work being performed under Metco Maintenance Contract for NESPS:**

- Flow control operations related to OMID/MID/NIEA sewer repair and upgrade projects are ongoing.
- Mechanical and Electrical corrective/preventative maintenance schedules continue.
- Coordination between GLWA, MID, NESPS, and Pump/Electrical Upgrade Project has not affected station operations nor hindered performance or abilities to meet demands.

## June 15, 2022 OMIDDD Board Meeting

- Wet well sediment inspection and bar screen cleaning are now quarterly tasks. The most recent inspection was performed on June 3, 2022. Based on recent review of historical data, sediment level has plateaued and, in some measurement locations, dropped. Based on the data and observations, the wet wells appear to be self-regulating/cleaning, with the exception of long-term accumulation of larger debris and cemented material which is not drawn into the pumps.
- The OMIDDD Project Team is continuing to review past wet well/bar screen data. This effort will be used in developing best practices maintaining overall de-ragging and sediment removal efforts. Options for future automated and/or optimized cleaning are being researched and considered.
- A NESPS Controls Workshop with the OMID team and GLWA is an ongoing process, designed around new operational parameters and control strategies.
- NESPS Health and Safety Plan finalized.



Recent Bar Screen Cleaning in process (upper photo)

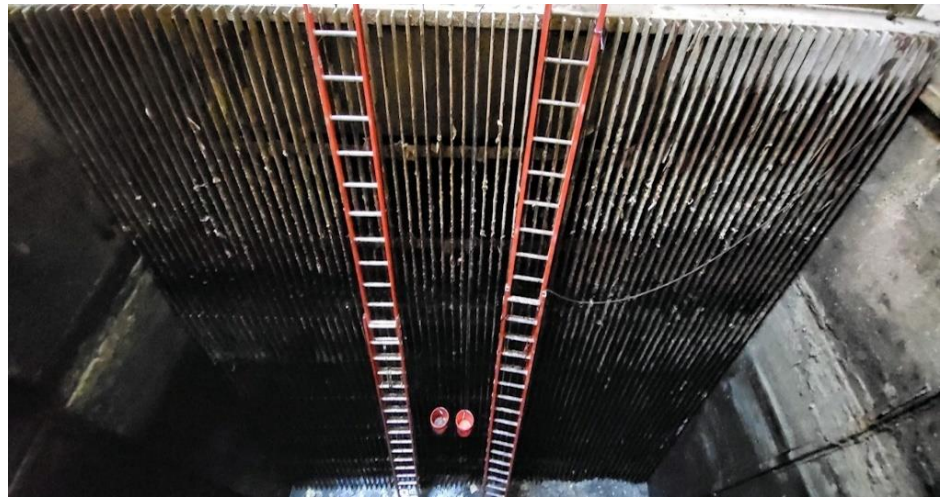

Recent Bar Screen Cleaning completed (lower photo)

### Overall NESPS Station Performance Report:

- Sanitary Pumps #2 #4, #5, and #6 ready for duty. Total pump capacity equals 500-cfs
- Major glitches within the Ovation system logic impacted Sanitary 5 and Sanitary 6 with premature stops and non- starts. A meeting was held with GLWA IT staff to resolve. Ovation server “crash” was found to be the culprit; issue remains a non-issue.
- Sanitary Pump #2 VFD (Variable Frequency Drive) issues have been resolved. Specifically, one of the three VFD cell cabinet exhaust blowers seized. Rotor has received the repaired blower.

## June 15, 2022 OMIDDD Board Meeting

Installation was completed May 6, 2022. An abandoned blower was found and is now being repaired. Following repair, it will become part of our spare part inventory.

- Sanitary Pump #6 exciter insulation resistance tested low during recent Preventative Maintenance checks. The exciter was dismantled and shipped to a local shop for repair. Costs were minimal and turnaround was quick. Currently performance is in line with normal operations.
- Specific data logging software has been installed within the VFD drive PLC. Siemens maintains the ability to monitor VFD performance and fault/trip conditions.
- Rotor integrated the existing Eaton Power Expert (Quality Power Monitoring Meter) located on the VFD Sanitary Pump #4 switchgear into the OMID SCADA system. We can now monitor/trend incoming DTE electrical power. No faults, voltage sags or spikes noted.
- A mechanical seal was installed on the wet well dewatering pump April 13 (taken from our spare part inventory). A spare mechanical seal was added back to inventory.
- New transformer (T3) has been energized and tied to the existing switchgear. Station now in preferred “double-ended” status whereby T3 and T4 utility transformers are both under load conditions.
- NEXGEN asset management in use.
- NESPS HVAC system performing as designed. Minor tweaking on-going.
- Bio Filter performance normal with no odor complaints or issues to report. Parameters checked daily and shared with Bio Aire on a weekly basis.
- Overall General Housekeeping tasks in order. Minor maintenance activities addressed in a timely manner.



**Ragging Removed from Bar Screens**

### **Control Structures Performance Report (CS-5, CS-6, CS-7, CS-8):**

- Daily flow control operations now support MID/OMID/NIEA repair and improvement projects.
- All LOTO protocols are in-place with no major issues to report.
- System-wide communications are good.
- CS-6 gate remains out of service. HESCO salvaged the counter-balance valve from the damaged CS-6 gate and will re-use it at CS-3. This will restore operability to MID CS-3 gate #1.
- Refurbishment plan of CS-6 is underway, quotes and scope of work are being identified. Details will follow.
- Preventative maintenance tasks and emergency inspections of control structures were completed after minor issues addressed. Reports are on file.

# June 15, 2022 OMIDDD Board Meeting

---

- CS-7 in stand-by mode ready for service. Blew a hydraulic hose May 24<sup>th</sup>. HESCO repaired and returned CS-7 back to service the same day.
- CS-8 in stand-by mode ready for service.
- CS-5 in stand-by mode ready for service.
- CS-9 in stand-by mode ready for service.
- PCI-5 Hobas lining repair is pending final insurance carrier approval.
- Routine daily rounds and inspection made with no major maintenance issues to report at this time.

## Other System Operation Issues

- O&M Manual currently being revised to include new structures, recently modified structures, new monitoring equipment, and recent inspection and repair status.
- EGLE has informally agreed to consent to use of all flow control structures for long term flow control. Request for formal consent is promised but not yet received.

## OMID Control Structure Upgrades Status:

- Hatch and Access improvements complete 8/14/20, CSM Contract closed-out.
- HESCO has provided a study of control structures that evaluates long-term operability, and recommends certain upgrades. ASI preparing a design scope and budget for such upgrades for OMIDDD consideration.

## OMID System 3-Year Spot Repairs Status:

- Remaining 3-year spot repair work consists of step removal at one manhole in PCI-8, delayed due to access issues and timing of other work.

## OMID System 6-Year Inspection Status:

- The 6-Year inspection began July 8, 2021. Flow Control delays have hampered inspections, although work is being performed intermittently and nearing completion.
- Some damage noted to the CIPP Liner installed in 42" section of PCI-11A. Current plan is for Doetsch to remove the damaged section, grind the edges, and assess if anything more is necessary. Work has been delayed due to permit issues.

## NIEA Repairs (Design/Construction)

### Contract 1 (PCI-4 Rehabilitation): In Construction

**Amt Invoiced:** Construction cost to date is \$8,959,332.46 representing 57.6 % of the Contract value.

**Schedule Status:** Current adjusted Substantial Completion date is December 2, 2022. Currently, the Contractor is operating in excess of 5 weeks behind the adjusted schedule but anticipates this shortfall can largely be made up once productive lining work begins.

# June 15, 2022 OMIDDD Board Meeting

## Contract 1 (PCI-4 Rehabilitation) Construction Status:

- Access shaft excavation, liner-plate TERS installation, headwall construction, and slab construction is complete, and access opening in the tunnel is completed. Geotechnical monitoring of construction activities indicates continuing stable conditions.
- Currently, 100% of the Channeline segments are now on site and being assembled, and over 90% of the Rockhard SCP segments have been manufactured and delivered to the jobsite. Progress continues on the QuakeWrap lining pipe at the Hastings, MI manufacturing facility.
- The Contractor is experiencing initial startup problems with their pipe carrier operation as well as the installation of the first segments. Efforts are underway to improve the pipe carrier to address both challenges.
- Initial transition section of QuakeWrap lining segment was installed last month; bulkhead complete. Difficulty homing first pipe sections has resulted in the need to chip away portions of the relined section in the upstream 110 feet.



Installation of Reinforcement on Pipe Carrier



Peeling Surface  
Coating of NESPS  
Central Discharge  
Chamber (Below and  
to Left)



Manhole Cone Replacement on Van Dyke



## June 15, 2022 OMIDDD Board Meeting



**Access Shaft Clean and Ready for Pipe Installation**



**Channel Line Sections Assembled and Ready for Installation**

### **Contract 2 (PCI-18/19 Rehabilitation): Design Complete**

**Amt Invoiced:** \$2,256,148 out of currently projected study/design budget of \$2,400,570;

**Schedule Status:** Contract 2: 100% design work complete; expected to bid in late 2022 pending permit and easement acquisition resolution and coordination with GLWA projects that impact flow control requirements.

#### **Contract 2 (PCI -18/19 Rehabilitation) Design Status:**

- NI-EA OMID Contract No. 2 PCI-18 & 19 Rehabilitation 100% drawing set has been workshopped with OMIDDD and is ready for advertisement, pending GLWA agreement.
- Flow control measures necessary to complete Contract 2 work are expected to impact a downstream GLWA project (DB-226). Contract 2 is being structured such that potential interference between the two contracts can be mitigated.
- Current City of Detroit permitting and easement issues are nearly resolved; certain follow-up issues remaining.
- Working with GLWA to develop cost sharing agreement; Draft agreement is currently being negotiated.

# June 15, 2022 OMIDDD Board Meeting

The **draft** line item schedule and budgets for OMID NIEA Contracts 1 and 2 are summarized:

Work Item/ Milestone	Estimated Budget Expenditure (Engineering)	Estimated Budget Expenditure (Contractor)	Estimated Delivery Date
Lining Study Final Report	\$126,744		10/30/2019
90%, 100% Design Package			3/20/2020 and 4/28/2020 (Contract 1) 4/16/2021* and TBD* (Contract 2)
MDEQ Submittal (Part 41)			4/28/2020 (Contract 1) Pending* (Contract 2)
Issued for Bid			6/10/2020 (Contract 1) 4/2022* (Contract 2)
Bid Opening			9/30/2020 (Contract 1) April 2022* (Contract 2)
Contract Award and NTP			12/16/2020 and 1/04/2021 (Contract 1) TBD* (Contract 2)
Subtotal - Design	\$2,400,570		
Final Completion of Construction	\$3,500,000	\$35,000,000	12/2/2022 (Contract 1) 8/30/2024 (Contract 2, estimated)

## NESPS Pump and Electrical Upgrades Project

**Budget Status:** \$1,280,139 billed out of current Design Budget of \$1,382,430; \$968,018 out of the current CCA Budget of \$2,443,262. Total construction budget currently established as \$45,309,742.13, including contingencies, through proposed C.O. #19). The total amount invoiced to date as of May 31, 2022, is \$ 26,793,838.53 (including the now completed and operational Control Structure 9 Bulkhead Gate facility, and adjusted for stored material inclusion in major work activities), representing 59% of the combined project (Pump & Electrical Upgrades and CS-9 Gate Installation).

**Schedule Status:** Currently work is approximately 6 months late, resulting from a combination of supply chain issues and other issues. Contractor is trying to make up time but will likely be unable to meet the scheduled completion date. Discussions for additional time and/or schedule adjustments are pending.

The following Design Team and Construction Services Effort is active:

- The new Sewage Pump # 3 and Motor have now been delivered to the NESPS and are in the process of installation. In addition, Sewage Pump and Motor No. 1 are undergoing installation. Factory performance tests have been satisfactorily conducted with each separate component, and the pump and motor assembly will be re-tested when in place at the NESPS.
- Electrical work on the primary cable installation from the transformers to the new metal clad switchgear is in progress and proceeding without issue.
- Structural concrete work is in progress and nearing completion for the Pump # 3 and # 1 foundation bases.



## June 15, 2022 OMIDDD Board Meeting

- A review of alternative energy saving methods and pump sequence remains ongoing, incorporating GLWA SCC comments.
- Construction Phase services (RFIs, Submittals) are ongoing, and the engineering team is reviewing and responding.
- Discharge piping work is underway on Pumps # 1 and # 3, including pressure testing.
- Chemical injection to seal groundwater infiltration at the existing discharge pipe wall penetrations is substantially complete, with final efforts on hold to observe the initial stages of grouting and determine if further measures may be required for final leak control.
- Small diameter conduit runs are being installed in the existing NESPS building with favorable progress, now approaching substantial completion for this activity.
- Pump 1 and Pump 3 have been shop tested and are now onsite undergoing installation.
- Knife Gate 1 is refurbished and has been reinstalled.
- The **draft** line item schedule and budget are summarized:

Work Item/ Milestone		Design/CCA Budget	Const Budget	Estimated Delivery Date
2	Final Basis of Design			5/31/2019
7	MDEQ Submittal (Part 41 Permit)			4/8/2020 (initial pkg)
8	90% Design Submittal			6/30/20
9	Final Package Development			8/14/2020
	Subtotal	\$3,826,000	\$44,100,000	
10	Substantial Completion	\$2,500,000 (est.)	\$44,100,000 (est.)	9/22/2023 (late)
11	Final Completion			12/21/2023 (late)

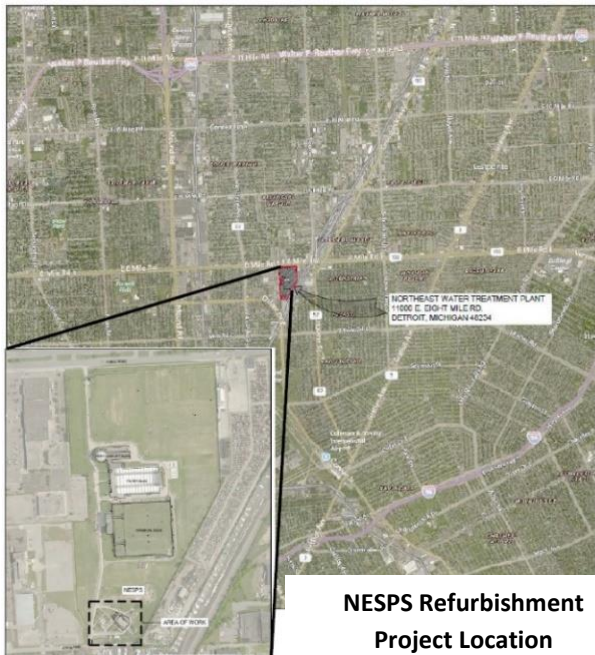

**NESPS Refurbishment  
Project Location**

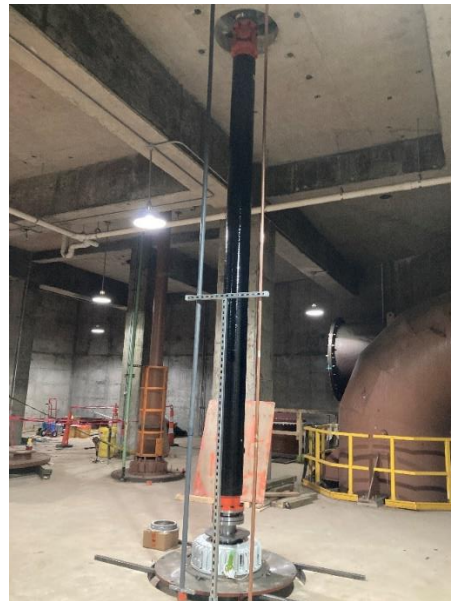

**Pump Drive Shaft Installation**

# June 15, 2022 OMIDDD Board Meeting

---



**Forming Pump 1 Thrust Block**



**Completed Pump 3 Thrust Block**



**Pump 1 Shaft Coupling Installation**

# June 15, 2022 OMIDDD Board Meeting

## CS-9 Gate Installation

**Budget Status:**

Total construction budget currently established as approximately \$3,314,218.01

**Schedule Status:**

Construction complete; Repairs pending

The following work is active:

- All major work is complete and the Hydrogate gate is in regular use for flow control management.
- Site restoration is substantially complete and will be fully completed following Hobas Repairs.
- Doetsch Environmental is engaged to provide Hobas Lining repair and platform repair services. Repairs on hold pending insurance carrier approval



CS-9 Project location

## Summary of OMID Design and Construction Status:

Work In Construction Since 2009							
Seg. No	Contract No. (Description)	Contractor	Const. Comp?	As-Builts Final?	Balancing Change Order?	Contractor Closed Out?	Easements Settled?
1	Contract 1 (CS-9, 5, 3)	Ric-Man	Y	Y	Y	Y	Y
1	Contract 2 (CS-6, 7, 8)	Ric-Man	Y	Y	Y	Y	Y
2	Contract 3-2E (Gatehouse)	IWPC (Weiss)	Y	Y	Y*	Y	N/A
2	Contract 3 (Grouting PCI-5 thru 8)	IWPC	Y	Y	Y	Y	Y
3	Contract 4 (Lining PCI-5 thru 8)	Jay Dee Cont.	Y	Y	Y	Y	Y
4	Contract 5 (Lining PCI-9, 10A/B)	Lanzo	Y	Y	Y	Y	N
4	Contract 6 (Lining PCI-11A)	Lanzo	Y	Y	Y	Y	Y
N/A	Contract 7 (Lining 110' of NIEA)	IWPC	Y	Y	Y	Y	N/A
N/A	Odor/Corrosion Control System	CSM	Y	Y	Y	Y	N/A
N/A	Control Structure Modifications	CSM/Hesco/MCE	Y/Y/Y	Y/Y/N	Y/N/N	Y/N/N	N/A
N/A	OMID Maintenance Repairs	Doetsch	Y	N	N	N	N/A
N/A	CS-9 Gate Modifications	Walsh as CMR	Y	N	N	N	Y
N/A	NESPS Pump & Electrical Upgrade	ASI; Walsh as CMAR	N	N	N	N	Y
N/A	NIEA-OMIDDD Contract 1 (PCI-4)	Marra	N	N	N	N	N

\* In process with Coating Issues Resolution and Change Order and Memo of Understanding approvals in review

# June 15, 2022 OMIDDD Board Meeting

Work Currently in Design/Study/Engineering		
Description	Design Consultant	Status
System-wide Odor/Corrosion Study	Jacobs	Study Complete, data gathering and modifications pending
NESPS & OMID Maintenance & Repairs	Metco	Engineering/Maintenance Ongoing
NIEA-OMIDDD Contract 2 (PCI-18/19)	NTH	Design Complete; pursuing cost sharing w/ GLWA
Emergency Pumping Plan	ASI/FKE	Draft Plan to be modified following ITC bypass pumping modifications

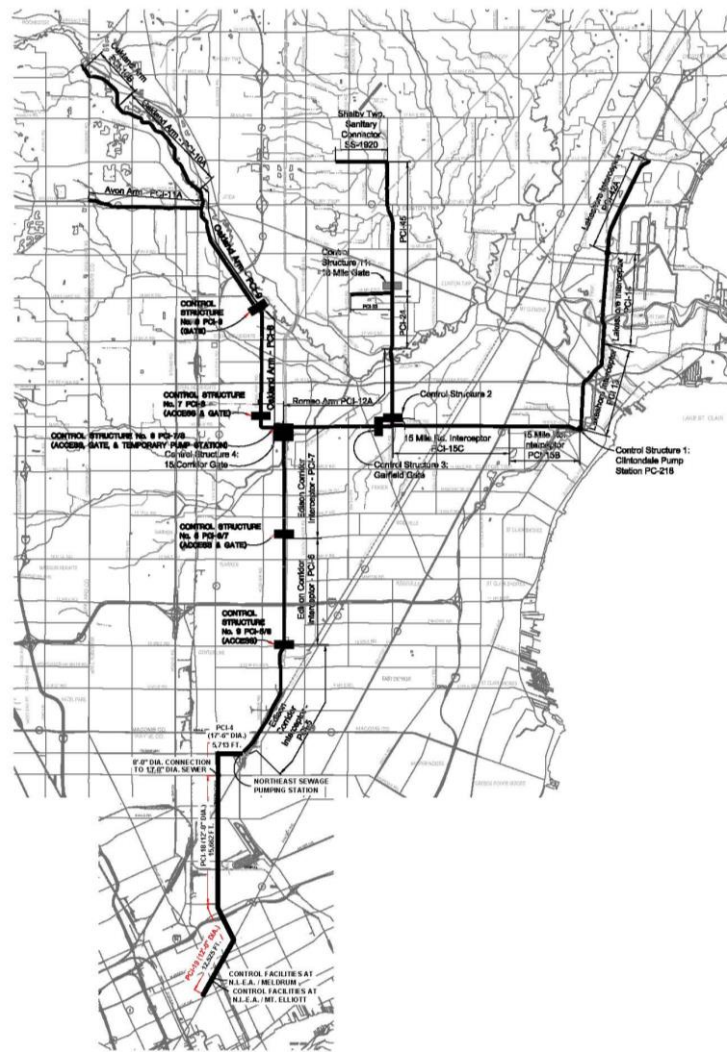

**Overview of OMID System in Oakland, Macomb, and Wayne County**

# June 15, 2022 OMIDDD Board Meeting

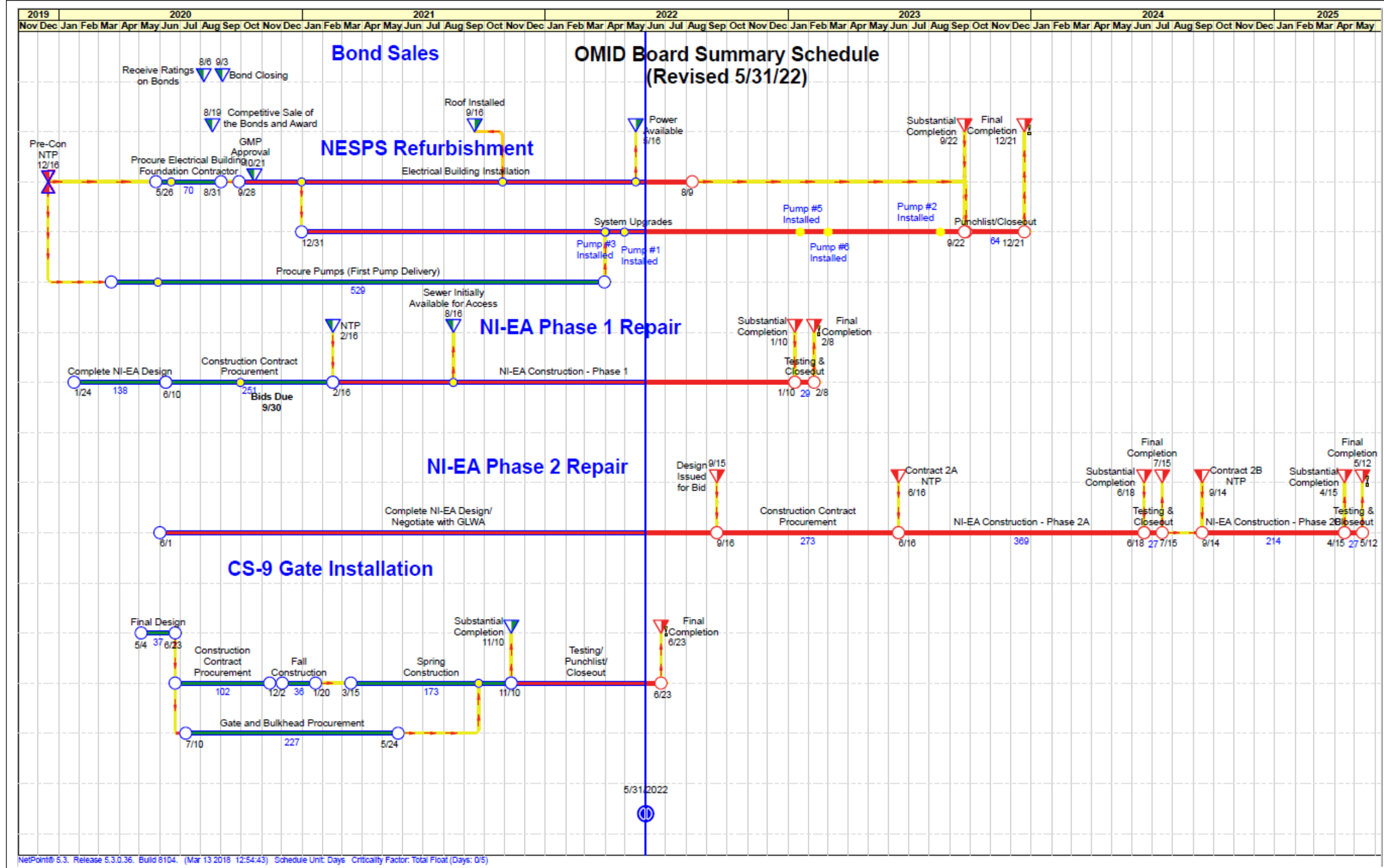



**Agenda Item No. 11**

Financial Reports – General Financial Report and  
Status of State Revolving Fund Financing and  
Other Financing

**OCM Project Work In Progress**

**Company** Oakland County  
**Projects and Project Hierarchies** PRJ-13308 OMID NI-EA CONSTRUCTION  
**Budget Structure** Project Task  
**Budget Name**  
**Period** FY2022 - May

Project	Start Date	Original Budget	Actuals MTD	Obligations YTD	Actuals YTD	Total Spend YTD	Actuals LTD	Variance
Project Expenses	11/1/2020	28,395,600.00	\$752,410.90	\$59,539.78	\$14,088,219.21	14,147,758.99	14,088,219.21	14,307,381
1 > Administration		584,000.00	\$0.00	\$0.00	\$0.00	0.00	0	584,000
1 > Contingency		2,581,000.00	\$0.00	\$0.00	\$0.00	0.00	0	2,581,000
1 > Engineering		478,000.00	\$3,629.60	\$0.00	\$106,063.24	106,063.24	106,063.24	371,937
1 > Engineering Consultants		4,913,000.00	\$58,988.02	\$9,693.45	\$2,328,870.66		2,328,870.66	2,584,129
						2,338,564.11		
1 > Facility Acquisition		17,983,600.00	\$689,624.00	\$0.00	\$11,450,391.26		11,450,391.26	6,533,209
						11,450,391.26		
1 > Inspection		260,000.00	\$0.00	\$0.00	\$0.00	0.00	0	260,000
1 > Legal and Financial		1,259,000.00	\$0.00	\$0.00	\$97,147.50		97,147.50	1,161,853
						97,147.50		
1 > Right of Way		265,000.00	\$169.28	\$0.00	\$76,326.74	76,326.74	76,326.74	188,673
1 > Standard		40,000.00	\$0.00	\$49,846.33	\$29,419.81	79,266.14	29,419.81	10,580
1 > Survey		32,000.00	\$0.00	\$0.00	\$0.00	0.00	0	32,000
Project Revenues	11/1/2020	0	\$0.00	\$0.00	\$24,171,142.65	(24,171,142.65)	24,171,142.65	
RC605572 - Special Assessments Revenue		0	\$0.00	\$0.00	\$2,206,043.00		2,206,043.00	
						(2,206,043.00)		
RC697551 - Issuance of Bonds		0	\$0.00	\$0.00	\$21,965,099.65		21,965,099.65	
						(21,965,099.65)		
<b>Revenue Over/ (Under) Expenses</b>							<b>10,082,923.44</b>	



**OCM Project Work In Progress**

**Company** Oakland County  
**Projects and Project Hierarchies** PRJ-13309 NESPS MECH-ELEC CONSTRUCTION  
**Budget Structure** Project Task  
**Budget Name**  
**Period** FY2022 - May

Project	Start Date	Original Budget	Actuals MTD	Obligations YTD	Actuals YTD	Total Spend YTD	Actuals LTD	Variance
Project Expenses	11/1/2020	54,086,000.00	\$28,984.12	\$1,263,378.00	\$23,789,745.60	25,053,123.60	23,789,745.60	30,296,254
1 > Administration		620,000.00	\$0.00	\$0.00	\$44,200.00	44,200.00	44,200.00	575,800
1 > Contingency		4,917,000.00	\$0.00	\$0.00	\$0.00	0.00	0	4,917,000
1 > Engineering		446,000.00	\$6,642.41	\$0.00	\$159,102.38	159,102.38	159,102.38	286,898
1 > Engineering Consultants		3,987,000.00	\$0.00	\$0.00	\$1,714,554.51	1,714,554.51	1,714,554.51	2,272,445
1 > Facility Acquisition		40,857,000.00	\$0.00	\$1,263,378.00	\$21,176,014.67	22,439,392.67	21,176,014.67	19,680,985
1 > Inspection		285,000.00	\$22,341.71	\$0.00	\$318,353.61	318,353.61	318,353.61	-33,354
1 > Legal and Financial		2,417,000.00	\$0.00	\$0.00	\$179,800.00	179,800.00	179,800.00	2,237,200
1 > Right of Way		393,000.00	\$0.00	\$0.00	\$0.00	0.00	0	393,000
1 > Standard		130,000.00	\$0.00	\$0.00	\$197,720.43	197,720.43	197,720.43	-67,720
1 > Survey		34,000.00	\$0.00	\$0.00	\$0.00	0.00	0	34,000
Project Revenues	11/1/2020	0	\$0.00	\$0.00	\$46,039,857.01	(46,039,857.01)	46,039,857.01	
RC605572 - Special Assessments Revenue		0	\$0.00	\$0.00	\$4,202,235.00		4,202,235.00	
RC697551 - Issuance of Bonds		0	\$0.00	\$0.00	\$41,837,622.01	(41,837,622.01)	41,837,622.01	
<b>Revenue Over/ (Under) Expenses</b>							<b>22,250,111.41</b>	

**OCM Project Work In Progress**

**Company** Oakland County  
**Projects and Project Hierarchies** PRJ-13252 OMID Segment 5  
**Budget Structure** Project Task  
**Budget Name**  
**Period** FY2022 - May

<b>Project</b>	<b>Start Date</b>	<b>Original Budget</b>	<b>Actuals MTD</b>	<b>Actuals YTD</b>	<b>Actuals LTD</b>	<b>Variance</b>
Project Expenses	8/1/2020	0	0.00	\$757,136.57	757,136.57	-757,137
1 > Administration		0	\$0.00	\$242,201.57	242,201.57	-242,202
1 > Legal and Financial		0	\$0.00	\$514,935.00	514,935.00	-514,935
<hr/>						
Project Revenues	8/1/2020	0	\$0.00	\$1,846,608.41	1,846,608.41	
RC605572 - Special Assessments Revenue		0	\$0.00	\$108,835.74	108,835.74	
RC655077 - Accrued Interest Adjustments		0	\$0.00	(\$161,449.04)	(161,449.04)	
RC655385 - Income from Investments		0	\$0.00	\$814,218.62	814,218.62	
RC697219 - Premiums on Bonds Sold		0	\$0.00	\$7,672,724.75	7,672,724.75	
RC697551 - Issuance of Bonds		0	\$0.00	(\$6,587,721.66)	(6,587,721.66)	
<b>Revenue Over/ (Under) Expenses</b>					<b>1,089,471.84</b>	

## **Agenda Item No. 12**

### **Invoices**



# Applied Science, Inc.

21455 Melrose Ave. Bldg R Suite 12 Southfield, MI 48075  
Phone: (313) 567-3990 Fax: (313) 567-3750  
www.asi-detroit.com

June 7, 2022

Project Invoice #40 (ASI Inv. #8151)

Joel Brown, P.E.  
Civil Engineer III  
Oakland County Water Resources Commissioner's Office  
One Public Works Drive, Building 95 West  
Waterford, MI 48328

Re: Northeast Sanitary Pump Station  
Contract #5470  
(ASI Job No. 1815)

**li# 41133 v#352**

Invoice Period: 5/1/22-5/28/22

Task No.	Task Description	Total This Invoice
1	Transition & Basis of Design	
	<b>Total:</b>	<b>\$ -</b>
		<b>Total This Invoice</b>
Task No.	Task Description	Total This Invoice
2	Design Services for Pump & Electrical Upgrades	
	<b>Total:</b>	<b>\$ -</b>
	Subconsultants:	
	<b>FK Engineering:</b>	<b>\$ -</b>
	<b>NTH Consultants</b>	<b>\$ -</b>
	ASI Markup 5%:	<b>\$ -</b>
	<b>Total Due This Invoice:</b>	<b>\$ -</b>
		<b>Total This Invoice</b>
Task No.	Task Description	Total This Invoice
3	Additional Special Services	
	<b>Total:</b>	<b>\$ -</b>
	Subconsultants:	
	<b>FK Engineering:</b>	<b>\$ -</b>
	ASI Markup 5%:	<b>\$ -</b>
	<b>Total Due This Invoice:</b>	<b>\$ -</b>
		<b>Total This Invoice</b>
Task No.	Task Description	Total This Invoice
5	Construction Services	
	<b>Total:</b>	<b>\$ 22,151.50</b>
	Subconsultants:	
	<b>NTH Consultants</b>	<b>\$ 29,963.46</b>
	<b>Metco Services</b>	<b>\$ 13,370.00</b>
	<b>FK Engineering:</b>	<b>\$ 6,721.75</b>
	ASI Markup 5%:	<b>\$ 2,502.76</b>
	<b>Direct Expenses:</b>	<b>\$ 2,025.33</b>
	<b>Total Due This Invoice:</b>	<b>\$ 76,734.80</b>
<b>Total Due This Invoice:</b>		<b>\$ 76,734.80</b>
	Previous Amount Invoiced:	<b>\$ 3,064,444.95</b>
	Total Invoiced To-Date	<b>\$ 3,141,179.75</b>
	Original Contract Task Total:	<b>\$ 4,198,380.00</b>
	Additional Budget:	<b>\$ 284,076.60</b>
	Current Contract Task Total:	<b>\$ 4,482,456.60</b>
	Amount Remaining:	<b>\$ 1,341,276.85</b>

JTB 6/10/2022

**84917-149015-730639-1-3309 engcon**



LG Design is a Subsidiary of CH2M Hill Engineers

Oakland-Macomb Interceptor Drain Drainage District  
Oakland County Water Resources Commissioner  
One Public Works Drive  
Waterford, MI 48328  
248-858-0958

Invoice Contact:  
[Sandy.Pepper@Jacobs.com](mailto:Sandy.Pepper@Jacobs.com)

Remit to:

LG Design, Inc.  
Attn: Judy Rives  
1041 East Butler Road  
Greenville, SC. 29607  
Tax ID : 20-0936384

Invoice Date: 5/31/2022  
CH2M HILL Project No. 705773CH  
CH2M HILL Invoice No. 705773CH039  
Sequential Invoice Number: 40

**PROFESSIONAL SERVICES RENDERED FOR THE OAKLAND-MACOMB INTERCEPTOR DRAIN DRAINAGE DISTRICT (OMIDD)  
BIOTRICKLING FILTER DESIGN AND CONSTRUCTION OVERSIGHT**  
This invoice includes labor and expenses for the period:  
From April 30, 2022 through May 27, 2022

**82912 - 6010101 - 149090 - 730639 - 5456 - Ch 21 - v#22147-  
exp. 6/26/23 - li#41407**

6/10/2022

**Authorized Amount: \$ 1,272,470.46**  
Current Invoice: \$ 1,407.08  
Total Invoiced: \$ 1,261,046.82  
Percent Complete: 99.10%  
Remaining Budget: \$ 11,423.64

**Total Amount Due: \$ 1,407.08**

Project/Task Number	Description	Total Budget	Previously Invoiced	Current Invoice	Total Invoiced	Percent Spent	Remaining Budget
1	PROJECT MANAGEMENT	\$ 33,527.00	\$ 33,504.07	\$ -	\$ 33,504.07	99.93%	\$ 22.93
2	PRELIMINARY DESIGN	\$ 73,599.00	\$ 73,519.37	\$ -	\$ 73,519.37	99.89%	\$ 79.63
3	FINAL DESIGN	\$ 195,027.00	\$ 195,009.84	\$ -	\$ 195,009.84	99.99%	\$ 17.16
4	BIDDING	\$ 31,841.46	\$ 31,840.94	\$ -	\$ 31,840.94	100.00%	\$ 0.52
5	CONSTRUCTION OBSERVATION	\$ 325,731.16	\$ 325,711.92	\$ -	\$ 325,711.92	99.99%	\$ 19.24
6	REVIEW SUBMITTALS	\$ 85,648.00	\$ 85,581.87	\$ -	\$ 85,581.87	99.92%	\$ 66.13
7	CHANGES & CLAIMS	\$ 17,361.00	\$ 17,274.11	\$ -	\$ 17,274.11	99.50%	\$ 86.89
8	SITE INSPECTION	\$ 31,998.07	\$ 31,975.53	\$ -	\$ 31,975.53	99.93%	\$ 22.54
9	PREPARE O&M MANUAL	\$ 21,715.50	\$ 21,695.78	\$ -	\$ 21,695.78	99.91%	\$ 19.72
10	PROVIDE OPERATING TRAINING	\$ 9,082.00	\$ 9,062.30	\$ -	\$ 9,062.30	99.78%	\$ 19.70
11	ASSIST WITH FACILITY START-UP	\$ 17,129.00	\$ 17,081.46	\$ -	\$ 17,081.46	99.72%	\$ 47.54
12	PREPARE RECORD DRAWINGS	\$ 9,803.00	\$ 9,715.13	\$ -	\$ 9,715.13	99.10%	\$ 87.87
13	WARRANTY & PERFORMANCE REVIEWS	\$ 15,370.00	\$ 15,352.92	\$ -	\$ 15,352.92	99.89%	\$ 17.08
14	PROJECT PLANNING	\$ 25,000.00	\$ 24,997.75	\$ -	\$ 24,997.75	99.99%	\$ 2.25
EX	EXPENSES	\$ 17,175.62	\$ 17,175.62	\$ -	\$ 17,175.62	100.00%	\$ -
SUB.METCO	ELECTRICAL ENGINEERING	\$ 74,194.50	\$ 74,194.50	\$ -	\$ 74,194.50	100.00%	\$ -
SUB.NTH	GEOTECH INVESTIGATION	\$ 262,327.15	\$ 262,327.15	\$ -	\$ 262,327.15	100.00%	\$ -
SUB.SDA	SITE SURVEY	\$ 5,250.00	\$ 5,250.00	\$ -	\$ 5,250.00	100.00%	\$ -
<b>Subtotal:</b>		\$ 1,251,779.46	\$ 1,251,270.26	\$ -	\$ 1,251,270.26	99.96%	\$ 509.20
<b>Allowance</b>		\$ 20,691.00	\$ 8,369.48	\$ 1,407.08	\$ 9,776.56	47.25%	\$ 10,914.44
<b>Total:</b>		\$ 1,272,470.46	\$ 1,259,639.75	\$ 1,407.08	\$ 1,261,046.82	99.10%	\$ 11,423.64

**OUTSTANDING INVOICES:**

INVOICE DATE	INVOICE #	AMOUNT
5/4/2022	705773CH038	\$ 1,190.42
<b>Total:</b>		\$ 1,190.42
Current invoice		\$ 1,407.08
<b>TOTAL DUE:</b>		\$ 2,597.50

**Payment term: 30 calendar days (NET)**

**FINANCE CHARGES WILL BE ASSESSED AT 1½ PERCENT PER MONTH (OR MAXIMUM PERMISSIBLE UNDER STATE LAW) ON ALL ACCOUNTS OVERDUE UNLESS STATED OTHERWISE IN OUR CONTRACT. CH2M HILL IS INCORPORATED.**

**Electronic payment details:**

Beneficiary Bank: **Bank of America**  
Account Name: **CH2M HILL Engineers, Inc.**  
Transit for ACH: **111000012**  
Transit for Wires: **026009593**  
Account No (USD): **4451457732**  
SWIFT: **BOFAUS3N**



Oakland-Macomb Interceptor Drain Drainage District  
 Attn: Megan Koss, Esq.  
 1 Public Works Drive  
 Waterford, MI 48328  
 WRClegalinvoices@oakgov.com

Invoice: 1202217  
 Date: 05/11/2022  
 Client: 58434  
 Matter: 424741

82912 - 6010101 - 149030 - 731073 -5113 - v#2788 - exp.  
 5/15/22

Matter Name: GLWA Model Wastewater Contract

6/10/2022

**LEGAL SERVICES RENDERED AND COSTS ADVANCED THROUGH APRIL 30, 2022**

Total Fees:	\$	1,782.00
<b>Total Due This Invoice:</b>	\$	<b>1,782.00</b>



Oakland-Macomb Interceptor Drain Drainage District  
 Attn: Megan Koss, Esq.  
 1 Public Works Drive  
 Waterford, MI 48328  
 WRClegalinvoices@oakgov.com

Invoice: 1202243  
 Date: 05/11/2022  
 Client: 58434  
 Matter: 404547

**84917 - 6010101 - 149015 - 731073 - 2603 - 1-3308 -  
 LEGAL- Ch.21 v#4716 - li#24138 - exp. 12/31/23**

Matter Name: Northeast Interceptor East Arm Improvements

6/10/2022

**LEGAL SERVICES RENDERED AND COSTS ADVANCED THROUGH APRIL 30, 2022**

Total Fees:	\$	5,157.00
Total Expenses:		178.00
<b>Total Due This Invoice:</b>	<b>\$</b>	<b>5,335.00</b>



CSM Mechanical, LLC

1235 Holden Ave.  
Milford, MI 48381

# Invoice

Date	Invoice #
5/31/2022	21OMIDD016

Bill To
OMIDD One Public Works Drive Building 95 West Waterford, MI 48328

Ship To
OMIDD 11010 E. State Fair St. Detroit, MI

82912 - 6010101 -149090- 730660 - 5817  
- Ch. 21- V#15750 li#44348 exp. 9/30/23

*John Brown*

6/10/2022

P.O. Number	Terms	Due Date
	Net 60	7/30/2022

Description	Amount
MAU2 VFD Replacement	12,964.30
<i>TM-6-6-22</i>	

<b>Total</b>		\$12,964.30
<b>Payments/Credits</b>		\$0.00
<b>Balance Due</b>		\$12,964.30

WE ACCEPT MASTER CARD, VISA, AND DISCOVER CARD

**“Relentlessly Helping Our Customers Achieve Success by Being an Integral, Caring and Innovative Mechanical Solutions Provider.”**





**INVOICE**

www.glwater.org

Account Name	OMID
Account Number	900-2101-W
Billing Date	06/02/2022
Due Date	07/04/2022

Billing Inquiries: (313) 965-9775

OMID  
 JOEL BROWN  
 OCWRC ASSISTANT CHIEF ENGINEER  
 ONE PUBLIC WORKS DR, BLDG 95 WEST  
 WATERFORD, MI 48328

**REMIT TO:**  
**Great Lakes Water Authority**  
**Attn: Treasury**  
**P.O. Box 441370**  
**Detroit, MI 48244-1370**

PREVIOUS BALANCE	\$133.00
ADJUSTMENTS AND PAYMENTS APPLIED	\$(133.00)
PREVIOUS AMOUNT DUE	\$0.00

**CURRENT CHARGES**

Quantity	DESCRIPTION	RATE	CHARGE
3	COST SHARING AGREEMENT - OMID DRONE USE - AIRTIME	40.00	\$120.00
1	COST SHARING AGREEMENT - OMID DRONE USE - O&M COST	13.00	\$13.00

**84917 - 149015 - 731458 - 1-3309 INS**

6/10/2022

DRONE USAGE ON MAY-19-2022

<b>TOTAL CURRENT CHARGES</b>	<b>\$133.00</b>
<b>TOTAL AMOUNT DUE</b>	<b>\$133.00</b>

PLEASE DETACH AND RETURN THIS PORTION WITH YOUR PAYMENT

Account Name	Account Number	Due Date	Amount Due
OMID	900-2101-W	07/04/2022	\$133.00

OMID  
 OCWRC ASSISTANT CHIEF ENGINEER  
 ONE PUBLIC WORKS DR, BLDG 95 WEST  
 WATERFORD, MI 48328

**AMOUNT REMITTED \$**

**REMIT TO: Great Lakes Water Authority**  
**Attn: Treasury**  
**P.O. Box 441370**  
**Detroit, MI 48244-1370**



**Knowledgeable • Professional • Attentive • Likeable**  
 29770 Hudson Drive Novi, MI 48377  
 Phone: (586) 978-7200  
 hesco-mi.com

Invoice No. 2213585

Date: 04/27/2022

**Billed To:** OMID Drainage District  
 1 Public Works Drive  
 Waterford MI 48328

**82912 - 149130 - 730660 - 5819 - Ch. 21 -  
 v#3091 - exp. 6/30/22 - li#42703**

6/10/2022

**Project:** 2019807S OMID Flow Control Structures

**Contact:** Terry Moore      **P.O.#** Sewer Fund #149130      **Salesperson:** David Burkel      **Due Date:** 05/27/2022

Description	Unit	Qty	Rate	Amount
<b>3/30/22 CS-6 Counterbalance Valve Removal</b> ✓				
WO 00585 – CS-6				
<b>Senior Tech</b>	Hours	7.00	185.00	1,295.00
Michael Sieron				
<b>Tech 1</b>	Hours	7.00	120.00	840.00
Jason Dietz				
<b>Tech 1</b>	Hours	7.00	120.00	840.00
Ken Jahn				
<b>Tech 1</b>	Hours	7.00	120.00	840.00
Matt Kierczak				

**Notes:**

WO 00585 – CS-6

*TM. 6.6.22*

Non-Taxable Amount:	3,815.00
Taxable Amount:	0.00
Sales Tax:	0.00
Total Invoice	3,815.00
Payments/Credits:	0.00
<b>Amount Due</b>	<b>3,815.00</b>



# KENNEDY INDUSTRIES

INNOVATE  
SOLVE  
MONITOR  
REPAIR

INVOICE		
DATE	NUMBER	PAGE
5/27/2022	631379	1 of 1

B OMI100  
I OAKLAND MACOMB INTERCEPTOR DRA  
L 1 PUBLIC WORKS DR.  
L SUBMIT INVOICES TO NEXGEN  
T WATERFORD, MI 48328  
O

S NORTH EAST PUMPING STATION  
H 8598 E. STATE FAIR AVE  
I DETROIT, MI 48234  
P

**82912-6010101-149090-730660-5825-ch.21-  
v#239 exp. 6/30/22**

6/10/2022

ATTENTION:

TERRY MOORE

313-8297207

TMOORE@METCOSERVICES.COM

CUSTOMER REF/PO #	JOB #	JOB TITLE	SLP	SHIPPING TYPE	TERMS
	0105960	NORTHEAST PUMP STATION, FIELD SERVICE, SANITARY	KES/PM	FIELD SERVICE	NET 60

QUANTITY		PART NO.	DESCRIPTION	UNIT PRICE	EXTENDED
B/O	Ship				
0.00	3.00	GRE550NORTHEASTPS	GLWA, NORTHEAST PUMP STATION KENNEDY INDUSTRIES PROVIDED (1) FIELD SERVICE TECHNICIAN(S) ONSITE ON 5/24/2022. PLEASE SEE THE ATTACHED SERVICE REPORT.	\$110.00	\$330.00
0.00	1.00	TRAVEL	SERVICE TRUCK	\$66.00	\$66.00

*TM. 6-6-22*

**PLEASE REMIT TO:  
KENNEDY INDUSTRIES, INC.  
P.O. BOX 930079  
WIXOM, MI 48393**

<p>This invoice is subject to and incorporates by reference Kennedy Industries, Inc.'s ("Kennedy") Terms &amp; Conditions (Rev'd 4/2019) and Customer Warranty available at <a href="http://www.kennedyind.com">www.kennedyind.com</a> which will be provided by email upon written request. Buyer expressly agrees to the provisions set forth in the Terms &amp; Conditions and Customer Warranty posted on Kennedy's website</p> <p><b>*TERMS OF PAYMENT ARE NET 30 DAYS FROM DATE OF INVOICE *A 7% PER ANNUM SERVICE CHARGE SHALL BE APPLIED TO ANY BALANCE *CREDIT CARD PAYMENTS ARE SUBJECT TO AN ADDITIONAL 3% CHARGE</b></p>	SUBTOTAL:	\$396.00
	TAX:	\$0.00
	TOTAL:	\$396.00

P.O. Box 930079 Wixom, MI 48393 - 4925 Holtz Drive Wixom, MI 48393 - Phone: 248-684-1200 - Fax: 248-684-6011

**www.KennedyInd.com**



16142 Collection Center Drive  
 Chicago, IL 60693-0002  
 (877) 759-4365

Oakland-Macomb Interceptor Drain **Drainage District (OMIDD)**  
**Attn: Joel Brown**  
 Building 95 West, One Public Works Dr  
 Waterford, MI 48328

Project: Northeast Sewage Pump Station

**84917 - 6010101 - 149015 - 730940 - STD - 4724 - 1-3309 - Ch. 21**

**JTB 6/10/2022**

Invoice # 7933	Page 1 of 1
Account Number	Date
OAKLINT-01	5/16/2022
BALANCE DUE ON	
6/20/2022	
AMOUNT PAID	Amount Due
	\$44,200.00

Payment Methods:

ACH/Wire Information

Bank of America

Acct Name: Meadowbrook Inc.

Acct Number: 5401978514

ACH: Acct ABA #: 071000039

Wire: Acct ABA #: 026009593

Mail and Make Checks Payable to:

Meadowbrook Insurance Agency

16142 Collection Center Drive

Chicago, IL 60693-0002

<b>NESPS Safety Consultant &amp; Administration</b>	Policy Number	OCIPNESPSADMIN21	Effective: 9/20/2021 to 9/20/2022
---	---------------	------------------	-----------------------------------

Item #	Trans Eff Date	Due Date	Trans	Description	Amount
385860	9/20/2021	6/20/2022	RENB	Final of 4 Quarterly Installments	\$44,200.00

Total Invoice Balance: \$44,200.00

Payment due upon receipt.



INVOICE NO. 1811-41

DATE: June 1, 2022

METCO PROJECT NO. 1811

INVOICE PERIOD: 5/2 thru 5/29/2022

Contract ID 0000000000000000000517

Vendor ID 000020486

TO: OMIDD

Water Resources Commissioner  
One Public Works Drive  
Waterford, MI 48328

Attn: Mr. Sid Lockhart, PE  
Deputy Chief Engineer/Special Projects Manager

TITLE: OMID & NESPS Operation and Maintenance

**Operational Plan**

**OMID Operations - Fund 82912, Program 149130, Account 730373 (3.1-3.4A & 3.4B) JTB 6/10/22**

Name	Title	Hrs.	Rate/Hr.	Amount
Raj Vijayendran, PE	Principal Engineer	0.0	\$ 215.00	\$ -
Terry Moore	Operations Manager	40.0	\$ 145.00	\$ 5,800.00
Terry Moore	Operations Manager (Overtim	7.0	\$ 195.00	\$ 1,365.00
Darrin Green	Staff Engineer	27.0	\$ 90.00	\$ 2,430.00
Darrin Green	Staff Engineer-(Overtime)	0.0	\$ 135.00	\$ -
Anthony Vozza	Staff Engineer	67.0	\$ 90.00	\$ 6,030.00
Anthony Vozza	Staff Engineer-(Overtime)	4.0	\$ 135.00	\$ 540.00
Rosana Santos	Administrative Assoc.	0.0	\$ 73.79	\$ -
<b>Subtotal OMID Operatons:</b>			<b>\$</b>	<b>16,165.00</b>

**NEPS Operations - Fund 82912, Program 149090, Account 730373 (3.1-3.4A & 3.4B) JTB 6/10/22**

Name	Title	Hrs.	Rate/Hr.	Amount
Raj Vijayendran, PE	Principal Engineer	8.0	\$ 215.00	\$ 1,720.00
Terry Moore	Operations Manager	40.0	\$ 145.00	\$ 5,800.00
Terry Moore	Operations Manager (Overtim	4.0	\$ 195.00	\$ 780.00
Darrin Green	Staff Engineer	32.0	\$ 90.00	\$ 2,880.00
Darrin Green	Staff Engineer-(Overtime)	0.0	\$ 135.00	\$ -
Anthony Vozza	Staff Engineer	16.0	\$ 90.00	\$ 1,440.00
Anthony Vozza	Staff Engineer-(Overtime)	8.0	\$ 135.00	\$ 1,080.00
Rosana Santos	Administrative Assoc.	4.0	\$ 73.79	\$ 295.16
<b>Subtotal NEPS Operations</b>			<b>\$</b>	<b>13,995.16</b>
<b>Subtotal Operations</b>			<b>\$</b>	<b>30,160.16</b>

**Maintenance & Asset Management**

**OMID Maintenance - Fund 82912, Program 149130, Account 730646 (3.2-3.3-3.4C & ALLOWANCE) JTB 6/10/22**

Name	Title	Hrs.	Rate/Hr.	Amount
Terry Moore	Operations Manager	40.0	\$ 145.00	\$ 5,800.00
Terry Moore	Operations Manager (Overtim	0.0	\$ 195.00	\$ -
Anthony Vozza	Staff Engineer	0.0	\$ 90.00	\$ -
Darrin Green	Staff Engineer	24.0	\$ 90.00	\$ 2,160.00
<b>Subtotal OMID Maintenance:</b>			<b>\$</b>	<b>7,960.00</b>

**NEPS Maintenance - Fund 82912, Program 149090, Account 730646 (3.2-3.3-3.4C & ALLOWANCE) JTB 6/10/22**

Name	Title	Hrs.	Rate/Hr.	Amount
Raj Vijayendran, PE	Principal Engineer	8.0	\$ 215.00	\$ 1,720.00
Terry Moore	Operations Manager	40.0	\$ 145.00	\$ 5,800.00
Terry Moore	Operations Manager (Overtim	1.0	\$ 195.00	\$ 195.00
Daniel Martel	Sr. Project Coordinator	0.0	\$ 145.00	\$ -
Sean Grant	Sr. Project Engineer	0.0	\$ 145.00	\$ -

Travis Ford	Sr. Project Engineer	0.0	\$	145.00	\$	-
Shailesh Patel	Sr. Project Engineer	0.0	\$	145.00	\$	-
Darrin Green	Staff Engineer	54.0	\$	90.00	\$	4,860.00
Darrin Green	Staff Engineer-(Overtime)	0.0	\$	135.00	\$	-
Anthony Vozza	Staff Engineer	55.0	\$	90.00	\$	4,950.00
Anthony Vozza	Staff Engineer-(Overtime)	0.0	\$	135.00	\$	-
Brandon Brochue	Designer/Drafter	0.0	\$	85.00	\$	-
<b>Subtotal:</b>					<b>\$</b>	<b>17,525.00</b>
<b>Maintenance Services (see attached invoices):</b>					<b>\$</b>	<b>581.83</b>
<b>Subtotal NEPS Maintenance:</b>					<b>\$</b>	<b>18,106.83</b>
<b>Subtotal Maintenance:</b>					<b>\$</b>	<b>26,066.83</b>

**NEPS Maintenance – Fund 82912, Program 149090, Account 730646 (Under NEXGEN ALLOWANCE) JT B 6/10/22**

<u>Name</u>	<u>Title</u>	<u>Hrs.</u>		<u>Rate/Hr.</u>		<u>Amount</u>
Raj Vijayendran, PE	Principal Engineer	0.0	\$	215.00	\$	-
Terry Moore	Operations Manager	0.0	\$	145.00	\$	-
Terry Moore	Operations Manager (Overtim	0.0	\$	195.00	\$	-
Sean Grant	Sr. Project Engineer	11.0	\$	145.00	\$	1,595.00
Darrin Green	Staff Engineer	0.0	\$	90.00	\$	-
Darrin Green	Staff Engineer-(Overtime)	0.0	\$	135.00	\$	-
Anthony Vozza	Staff Engineer	0.0	\$	90.00	\$	-
Abhishek Shah	Staff Engineer	98.0	\$	90.00	\$	8,820.00
Brandon Brochue	Designer/Drafter	0.0	\$	85.00	\$	-
<b>Subtotal Maintenance:</b>					<b>\$</b>	<b>10,415.00</b>

**Task 12.0 - As-Needed Services - Fund 82912, Program 149130, Account 730373 (3.1-3.4A & 3.4B) JT B 6/10/2022**

<b>Additional General/Excess Liability Insurance Fee:</b>	<b>\$</b>	<b>31,763.62</b>
<b>Subtotal 12.0:</b>	<b>\$</b>	<b>31,763.62</b>

**TOTAL AMOUNT DUE THIS INVOICE: \$ 98,405.61**



**MOTOR CITY ELECTRIC TECHNOLOGIES INC.**  
 AUTOMATION AND CONTROLS SOLUTIONS  
 9440 GRINNELL  
 DETROIT, MI 48213-1151  
 PHONE (313) 921-5300 FAX (313) 921-5310  
 "AN EQUAL OPPORTUNITY EMPLOYER"

# INVOICE

OMID  
 ONE PUBLIC WORKS DRIVE, BUILDING 95  
 WATERFORD, MI 48328-

Customer  
 PO Number

Job Number	Sub Job	Contract Number	Date Performed	Application	
				Date	Number
922567	0	001	5/5/2022	6/2/2022	94498

SID LOCKHART

Item No	Description of Work	Contract Amount	Previous Billings	Current Amount	To Date Complete & Stored	Balance To Finish	Current Retainage
001	NESP SCADA CUTOVER	\$180.00	-	\$180.00	\$180.00	-	-
<b>Totals:</b>		<b>\$180.00</b>		<b>\$180.00</b>	<b>\$180.00</b>		
Less Retained:				-			
<b>Invoice Total:</b>				<b>\$180.00</b>			

AS NEEDED ELECTRICAL AND ENGINEERING SERVICE

SEE ATTACHED INVOICE SUMMARY AND FIELD REPORT

WORK PERFORMED 5/5/2022 - WORK ORDER NO. 00631

*TM. 6.6.22*

**82912 - 6010101 - 149090- 730660 - 5469 - Ch. 21 - v# 7755 - li# 41132 - exp. 12/31/23**

*JL Ben*

6/10/2022

complete electrical construction

"We hereby certify that the articles and services covered by this invoice were produced and performed in compliance with all applicable requirements of Section 6, 7 and 12 of the Fair Labor Standards Act, as amended, and of regulations and orders of the United States Department of Labor issued under Section 14 thereof."



**MOTOR CITY ELECTRIC TECHNOLOGIES INC.**

AUTOMATION AND CONTROLS SOLUTIONS

9440 GRINNELL

DETROIT, MI 48213-1151

PHONE (313) 921-5300 FAX (313) 921-5310

"AN EQUAL OPPORTUNITY EMPLOYER"

# INVOICE

OMID  
ONE PUBLIC WORKS DRIVE, BUILDING 95  
WATERFORD, MI 48328-

Customer  
PO Number

Job Number	Sub Job	Contract Number	Date Performed	Application	
				Date	Number
922567	0	001	5/18/2022	6/2/2022	94499

SID LOCKHART

Item No	Description of Work	Contract Amount	Previous Billings	Current Amount	To Date Complete & Stored	Balance To Finish	Current Retainage
001	NESP SCADA CUTOVER	\$225.00	-	\$225.00	\$225.00	-	-
<b>Totals:</b>		<b>\$225.00</b>		<b>\$225.00</b>	<b>\$225.00</b>		
Less Retained:				-			
<b>Invoice Total:</b>				<b>\$225.00</b>			

AS NEEDED ELECTRICAL AND ENGINEERING SERVICE

SEE ATTACHED FIELD REPORT AND INVOICE SUMMARY

**82912 - 6010101 - 149130-730660 - 5469 - Ch. 21 - v# 7755 - li# 41132 - exp. 12/31/23**

*Jed Ben*

6/10/2022

WORK PERFORMED 5/18/2022 - WORK ORDER NO. 00639

*TM - 6.6.22*

complete electrical construction

"We hereby certify that the articles and services covered by this invoice were produced and performed in compliance with all applicable requirements of Section 6, 7 and 12 of the Fair Labor Standards Act, as amended, and of regulations and orders of the United States Department of Labor issued under Section 14 thereof."





**MOTOR CITY ELECTRIC TECHNOLOGIES INC.**

AUTOMATION AND CONTROLS SOLUTIONS

9440 GRINNELL

DETROIT, MI 48213-1151

PHONE (313) 921-5300 FAX (313) 921-5310

"AN EQUAL OPPORTUNITY EMPLOYER"

# INVOICE

OMID  
ONE PUBLIC WORKS DRIVE, BUILDING 95  
WATERFORD, MI 48328-

Customer  
PO Number

Job Number	Sub Job	Contract Number	Date Performed	Application	
				Date	Number
922567	0	001	5/19/2022	6/2/2022	94501

SID LOCKHART

Item No	Description of Work	Contract Amount	Previous Billings	Current Amount	To Date Complete & Stored	Balance To Finish	Current Retainage
001	NESP SCADA CUTOVER	\$90.00	-	\$90.00	\$90.00	-	-
<b>Totals:</b>		<b>\$90.00</b>		<b>\$90.00</b>	<b>\$90.00</b>		
Less Retained:				-			
<b>Invoice Total:</b>				<b>\$90.00</b>			

AS NEEDED ELECTRICAL AND ENGINEERING SERVICE

SEE ATTACHED INVOICE SUMMARY AND FIELD REPORT

**82912 - 6010101 - 149090- 730660 - 5469 - Ch. 21 - v# 7755 - li# 41132 - exp. 12/31/23**

6/10/2022

WORK PERFORMED 5/19/2022 WORK ORDER NO. 00640

*TM - 6.6.22*

complete electrical construction

"We hereby certify that the articles and services covered by this invoice were produced and performed in compliance with all applicable requirements of Section 6, 7 and 12 of the Fair Labor Standards Act, as amended, and of regulations and orders of the United States Department of Labor issued under Section 14 thereof."



**NTH Consultants, Ltd.**  
Infrastructure Engineering  
and Environmental Services

**82912 - 6010101 - 149662 - 730639 - 2603 - 1-3015 - ch 21 -  
engcon v#4716 - li#24138 - exp. 12/31/23**

OMI Drain Drainage District  
One Public Works Drive  
Building 95 West  
Waterford, MI 48328

6/10/2022

Invoice # : 629630  
Project : 61-190044  
Invoice Group : REPAIRS  
Invoice Date : 6/2/2022

Attention: Sid Lockhart

For Professional Services Rendered from **01/22/2022 - 05/20/2022**

OMID System Immediate Repairs

AMP/Inspection Reports (Task 01) \$4,587.37  
Rehabilitation Design (Task 02) \$71,617.66  
Construction Observation (Task 03) \$178,109.97  
**\$254,315.00**

Analysis of Costs		This Invoice	Cumulative
Direct Salaries (Task 01 & 02)		\$ 161.45	\$ 59,267.23
Overhead %	188.00	303.53	111,422.39
Total Regular Labor Expense		464.98	170,689.62
<b>Total Direct Labor</b>		<b>464.98</b>	<b>170,689.62</b>
<b>Profit / Fixed Fee %</b>	<b>12.00</b>	<b>55.80</b>	<b>20,482.75</b>
Direct Expenses Charge		0.00	3,685.50
Expense Multiplier %	5.00	0.00	234.29
Direct Subcontractor Charge		0.00	40,248.30
Subcontractor/Subconsultant Multiplier %	5.00	0.00	2,012.46
<b>Total Other Direct Charges Reimbursables</b>		<b>0.00</b>	<b>46,180.55</b>
<b>Total Costs:</b>		<b>520.78</b>	<b>237,352.92</b>
<b>Total Due This Invoice</b>		<b>\$ 520.78</b>	<b>\$ 237,352.92</b>



**84917 - 6010101 - 149015 - 730639 - 2603 - 1-3308 - Ch.21**  
**v#4716 - li#24138 - exp. 12/31/23**

JTB

6/10/2022

Omi Drain Drainage District  
One Public Works Drive  
Building 95 West  
Waterford, MI 48328

Invoice #: 629631  
Project: 61-190078  
Invoice Group: NI-EA  
Invoice Date: 6/2/2022

Attention: Sid Lockhart

For Professional Services Rendered from

4/23/2022 - 5/20/2022

Engineering Design Services for Rehabilitation of NI-EA Sections PCI-4

Task 01	Project Management	\$276,159.00
Task 02	Condition Assessment	\$241,609.00
Task 03	Subsurface Utility Engineering	\$65,579.00
Task 04	Basemap Survey	\$89,327.00
Task 05	Geotechnical Investigation	\$134,797.00
Task 05A	7-Mile Utility Exploration/Design	\$0.00
Task 05B	Additional Geotech for PCI-4 Shaft	\$0.00
Task 06	Environmental Study	\$60,642.00
Task 07	Basis of Design	\$379,785.00
Task 08	Rehabilitation Design	\$282,099.00
Task 09	Contract Drawings	\$235,070.00
Task 10	Contract Specifications	\$188,178.00
Task 11	Construction Costs	\$27,761.00
Task 12	Permits & Coordination	\$25,655.00
Task 13	Bidding Assistance	\$198,402.00
Task 14	Gate Automation	\$68,770.00
Task 15	Odor & Air Flow Study	\$84,926.00

Preliminary Budget Amount **\$2,358,759.00**  
Percent Complete: 92.42%

Analysis of Costs	This Invoice	Cumulative
Direct Salaries	\$ 588.86	\$ 310,231.45
Overhead %	188.00 1,107.06	583,235.15
Total Regular Labor Expense	1,695.92	893,466.60
<b>Total Direct Labor</b>	<b>1,695.92</b>	<b>893,466.60</b>
<b>Profit / Fixed Fee %</b>	<b>12.00 203.51</b>	<b>107,215.98</b>
Direct Expenses Charge	0.00	27,671.41
Expense Multiplier %	5.00 0.00	1,383.61
Direct Subcontractor Charge	46,399.23	1,085,160.19
Subcontractor/Subconsultant Multiplier %	6.00 2,783.96	65,109.77
<b>Total Other Direct Charges Reimbursables</b>	<b>49,183.19</b>	<b>1,179,324.98</b>
<b>Total Costs:</b>	<b>51,082.62</b>	<b>2,180,007.56</b>
<b>Total Due This Invoice</b>	<b>\$ 51,082.62</b>	<b>\$ 2,180,007.56</b>



**84917 -6010101 -149015 -731444 - 2603 -1-3308- ch 21 v#4716 - li#24138  
- exp. 12/31/23**

**JTB 6/10/2022**

**OMI Drain Drainage District  
One Public Works Drive  
Building 95 West  
Waterford, MI 48328**

**Invoice # : 629632  
Project : 61-200186  
Invoice Group : \*\*  
Invoice Date : 6/2/2022**

**Attentior Sid Lockhart**

**For Professional Services Rendered from 4/23/2022 - 5/20/2022**

Provide Engineering Services for OMID NI-EA Contract No.1 PCI-4 Rehabilitation Project and CS-9 Gate Installation Project D-425

<b>Task 01</b>	<b>NI-EA OMID Contract No. 1 CCA</b>	<b>\$2,257,340.89</b>
<b>Task 02</b>	<b>OMID CS-9 Gate CCA</b>	<b>\$217,468.00</b>
	<b>Preliminary Budget Amount</b>	<b>\$2,474,808.89</b>
	<b>Percent Complete:</b>	56.86%

Analysis of Costs		This Invoice	Cumulative
Direct Salaries	\$	25,432.44	\$ 265,645.64
Overhead %	188.00	47,812.99	499,413.81
Total Regular Labor Expense		73,245.43	765,059.45
<b>Total Direct Labor</b>		<b>73,245.43</b>	<b>765,059.45</b>
<b>Profit / Fixed Fee %</b>	12.00	8,789.45	91,807.15
Direct Expenses Charge		2,459.42	12,186.58
Expense Multiplier %	5.00	122.98	609.33
Direct Subcontractor Charge		6,805.01	507,149.21
Subcontractor/Subconsultant Multiplier %	6.00	408.31	30,429.01
Direct Unit Rate Charge		0.00	0.00
<b>Total Other Direct Charges Reimbursables</b>		<b>9,795.72</b>	<b>550,374.13</b>
<b>Total Costs:</b>		<b>91,830.60</b>	<b>1,407,240.73</b>
<b>Total Due This Invoice</b>		<b>\$ 91,830.60</b>	<b>\$ 1,407,240.73</b>



**84917- 6010101 - 149015 - 731458 - 2603 - 1-3309- ch 21 -  
engcon v#4716 - li#24138 - exp. 12/31/23**

*Jed Ben*

6/10/2022

Omi Drain Drainage District  
One Public Works Drive  
Building 95 West  
Waterford, MI 48328

Invoice # : 629634  
Project : 61-200280  
Invoice Group : CMT  
Invoice Date : 6/2/2022

Attentior Sid Lockhart

For Professional Services Rendered from **4/23/2022 - 5/20/2022**

Provide Engineering and Consulting Services regarding NESPS Pumping and Electrical System Upgrade (D-421)

Task 01	CMT Services	<b>\$130,138.00</b>
Task 02	Tnemec Coating Observation	<b>\$0.00</b>
	<b>Preliminary Budget Amount</b>	<b>\$130,138.00</b>
	<b>Percent Complete:</b>	80.58%

Analysis of Costs	This Invoice	Cumulative
Direct Salaries	\$ 297.81	\$ 27,706.87
Overhead %	188.00 559.88	52,088.94
Total Regular Labor Expense	857.69	79,795.81
<b>Total Direct Labor</b>	<b>857.69</b>	<b>79,795.81</b>
<b>Profit / Fixed Fee %</b>	<b>12.00 102.92</b>	<b>9,575.50</b>
Direct Expenses Charge	28.57	14,751.25
Expense Multiplier %	5.00 1.43	737.57
Direct Subcontractor Charge	0.00	10.00
Subcontractor/Subconsultant Multiplier %	6.00 0.00	0.60
Direct Unit Rate Charge	0.00	0.00
<b>Total Other Direct Charges Reimbursables</b>	<b>30.00</b>	<b>15,499.42</b>
<b>Total Costs:</b>	<b>990.61</b>	<b>104,870.73</b>
<b>Total Due This Invoice</b>	<b>\$ 990.61</b>	<b>\$ 104,870.73</b>



**NTH Consultants, Ltd.**  
 Infrastructure Engineering  
 and Environmental Services

**82912 - 6010101 - 149662 - 731458- 2603 - Ch. 21 - v#238 - li#24138 - exp. 12/31/23**

*JL Brun*

6/10/2022

Omi Drain Drainage District  
 One Public Works Drive  
 Building 95 West  
 Waterford, MI 48328

Invoice # : 629635  
 Project : 61210124  
 Invoice Group : \*\*  
 Invoice Date : 6/2/2022

Attention Sid Lockhart

For Professional Services Rendered from 4/23/2022 - 5/20/2022

Consulting Services Regarding 2021 OMID System Inspection

Task 01 Inspection and Reporting \$526,974.00  
 Preliminary Budget Amount \$526,974.00  
 Percent Complete: 49.19%

Analysis of Costs	This Invoice	Cumulative
Direct Salaries	\$ 802.59	\$ 15,696.48
Overhead %	188.00 1,508.87	29,509.38
Total Regular Labor Expense	2,311.46	45,205.86
<b>Total Direct Labor</b>	<b>2,311.46</b>	2,311.46
<b>Profit / Fixed Fee %</b>	<b>12.00 277.38</b>	<b>5,424.70</b>
Direct Expenses Charge	0.00	855.92
Expense Multiplier %	5.00 0.00	42.82
Direct Subcontractor Charge	468.40	195,936.20
Subcontractor/Subconsultant Multiplier %	6.00 28.10	11,756.17
Direct Unit Rate Charge	0.00	0.00
<b>Total Other Direct Charges Reimbursables</b>	<b>496.50</b>	<b>208,591.11</b>
<b>Total Costs:</b>	<b>3,085.34</b>	<b>259,221.67</b>
<b>Total Due This Invoice</b>	<b>\$ 3,085.34</b>	<b>\$ 259,221.67</b>



**NTH Consultants, Ltd.**  
Infrastructure Engineering  
and Environmental Services

**82912 - 149090 - 730639 - 2603 - Ch 21 - v#4716 exp. 12/31/23**  
**li#24138**

OMI Drain Drainage District *Jed Bru* 6/10/2022  
One Public Works Drive  
Building 95 West  
Waterford, MI 48328

Invoice #: 629636  
Project: 61-210313  
Invoice Group: \*\*  
Invoice Date: 6/2/2022

Attention Sid Lockhart

For Professional Services Rendered from **4/23/2022** - **5/20/2022**

Consulting Services Regarding Additional OMID Rehabilitation Program 2021 Closeout Services and As-Needed NESPS Maintenance Tasks

Task 01	Contract 3 NESPS Rehab Closeout	\$9,563.00
Task 02	PCI-4 Liner Deterioration Closeout	\$10,939.00
Task 03	Discharge Pipe Coating Rehabilitation	\$27,930.00
Task 04	NESPS Wet Well Sediment Survey	\$19,639.00
	<b>Preliminary Budget Amount</b>	<b>\$68,071.00</b>
	<b>Percent Complete:</b>	63.84%

		This Invoice	Cumulative
<b>Analysis of Costs</b>			
Direct Salaries		\$ 56.23	\$ 8,460.73
Overhead %	188.00	105.71	15,906.17
Total Regular Labor Expense		161.94	24,366.90
<b>Total Direct Labor</b>		<b>161.94</b>	<b>24,366.90</b>
<b>Profit / Fixed Fee %</b>	12.00	<b>19.43</b>	<b>2,924.02</b>
Direct Expenses Charge		0.00	0.00
Expense Multiplier %	5.00	0.00	0.00
Direct Subcontractor Charge		697.91	15,393.62
Subcontractor/Subconsultant Multiplier %	5.00	34.90	769.69
<b>Total Other Direct Charges Reimbursables</b>		<b>732.81</b>	<b>16,163.31</b>
<b>Total Costs:</b>		<b>914.19</b>	<b>43,454.23</b>
<b>Total Due This Invoice</b>		<b>\$ 914.18</b>	<b>\$ 43,454.23</b>



**NTH Consultants, Ltd.**  
Infrastructure Engineering  
and Environmental Services

OMI Drain Drainage District  
One Public Works Drive  
Building 95 West  
Waterford, MI 48328

Invoice # : 629637  
Project : 61210495  
Invoice Group :  
Invoice Date : 6/2/2022

Attention: Sid Lockhart

For Professional Services Rendered from 4/23/2022 - 5/20/2022

Authorization per Engineering Work Order D 439 date 12/03/2021  
82912-149662-730639-Cont#1-2603 Exp (12/31/21-Rev)  
82912- 6010101- 149662-730639- 2603 - Ch.21 - v# 4716 - li #24138 - exp. 12/31/23

6/10/2022

Additional OMID NESPS Maintenance Engineering Services

Task 01	NESPS Health and Safety Audit	\$16,137.00
Task 02	Control Structure 6 (CS-6) Emergency Bypass System Design	\$39,643.00
Task 03	Wet Wall Screen Cleaning Equipment	\$17,069.00
Task 04	Control Structure Gate Inspection	\$10,022.00

Preliminary Budget Amount \$82,871.00  
Percent Complete: 63.87%

Analysis of Costs	This Invoice	Cumulative
Direct Salaries	\$ 191.26	\$ 11,790.86
Overhead %	188.00 <u>359.57</u>	<u>22,166.81</u>
Total Regular Labor Expense	550.83	33,957.67
<b>Total Direct Labor</b>	<b>550.83</b>	<b>33,957.67</b>
<b>Profit / Fixed Fee %</b>	12.00 <b>66.09</b>	4,074.91
Direct Expenses Charge	0.00	319.94
Expense Multiplier %	5.00 0.00	16.00
Direct Subcontractor Charge	0.00	13,738.10
Subcontractor/Subconsultant Multiplier %	6.00 0.00	824.29
<b>Total Other Direct Charges Reimbursables</b>	<u>0.00</u>	<u>14,898.33</u>
<b>Total Costs:</b>	<u>616.92</u>	<u>52,930.91</u>
<b>Total Due This Invoice</b>	<u>\$ 616.93</u>	<u>\$ 52,930.92</u>





Oakland County Water Resources Commissioner  
Attn: Sid Lockhard, P.E.  
One Public Works Drive  
Building 95-West  
Waterford 48328

June 7, 2022

Invoice No: 03559.01 - 24

**84917 - 6010101 - 149015 - 731458- 6096- 1-3308 - ch21 - engcon - v#16918**  
**- exp. 5/29/23**

**6/10/2022**

Project 03559.01 Oakland-Macomb Interceptor Drainage 2020

**Professional Services from May 1, 2022 to May 31, 2022**

**Professional Personnel**

		<b>Hours</b>	<b>Rate</b>	<b>Amount</b>	
Zann, John		66.00	94.00	6,204.00	
	Totals	66.00		6,204.00	
	<b>Total Labor</b>				<b>6,204.00</b>

**Additional Fees**

Overhead	149.10 % of 6,204.00	9,250.16	
Profit	10.00 % of 15,454.16	1,545.42	
	<b>Total Additional Fees</b>		<b>10,795.58</b>

**Billing Limits**

	<b>Current</b>	<b>Prior</b>	<b>To-Date</b>
Total Billings	16,999.58	226,661.08	243,660.66
Limit			450,000.00
Remaining			206,339.34

**Total this Invoice                    \$16,999.58**

Please remit payment to PMA CONSULTANTS LLC, PO BOX 675234, DETROIT, MI 48267-5234. Please direct any questions regarding this invoice to Samantha Zeisler, Project Administrator, at 734-418-7897 or szeisler@pmaconsultants.com

## **Agenda Item No. 13**

Other Business

**Agenda Item No. 14**

Adjourn