

AGENDA

Oakland-Macomb Interceptor Drain Drainage Board Macomb and Oakland Counties

March 16, 2022 – 11:30 a.m.

Office of the Oakland County Water Resources Commissioner
One Public Works, Building 95 West
Waterford, Michigan, and Microsoft Teams

1. Call meeting to order

Board Members:

Michael Gregg, Chair, Michigan Department of Agriculture and Rural Development
Candice Miller, Macomb County Public Works Commissioner
Jim Nash, Oakland County Water Resources Commissioner

2. Motion to approve the meeting agenda for March 16, 2022
3. Motion to approve the Drainage District Board Meeting Minutes from February 16, 2022
4. Public Comment
5. Memorandum requesting the Board approve the Budget and Flow Allocations for 2022/2023
6. Motion to approve the following Change Orders:
 - a) Walsh Construction Change Order No.20 for the NESPS Pump & Electrical Upgrades Project for a net increase in the amount of \$215,255.18
 - b) Marra Services, Inc. Change Order No.2 for the NIEA OMID Contract 1 PCI-4 Rehabilitation Project for a net increase in the amount of \$143,806.88
7. Motion to approve the following Construction Estimates:
 - a) Construction Estimate No.17 for Walsh Construction for NESPS Pump & Electrical Upgrades Project (GMP Phase) in the amount of \$24,647.47 with a partial retainage overpayment to the contractor in the amount of \$63,886.32
 - b) Construction Estimate No. 12 for Walsh Construction for CS-9 Gate Installation with a reserve payment to the Contractor in the amount of \$48,629.00
 - c) Construction Estimate No.12 for Marra Services for NI-EA Contract No. One for PCI 4 Rehabilitation in the amount of \$175,867.60 with a transfer to the Oakland County Treasurer in the amount of \$19,543.85
8. Report/Update – Status of OMID Repairs Project
9. Financial Reports – General Financial Report and Status of State Revolving Fund Financing and Other Financing

10. Motion to approve the following invoices:

a) Reimbursement of Oakland County WRC-Incurred Expenses and Costs			
1)	Labor/Fringes/Non-Direct Labor Factor		
	• Segment 5 NI-EA Construction	\$	3,894.57
	• Segment 5 NESPS Mech./Elect. Construction	\$	18,111.49
2)	Equipment Charges		
	• Segment 5 NI-EA Construction	\$	158.01
	• Segment 5 NESPS Mech./Elect. Construction	\$	1,709.78
b) ASI, Inc.			
	Invoice No. 37	NESPS	\$ 72,559.95
c) Clark Hill			
1)	Invoice No. 1174160	NI-EA	\$ 5,913.00
2)	Invoice No. 1174161	O&M	\$ 4,698.00
d) CH2M			
	Invoice No. 37	O&M	\$ 4,409.10
e) CSM Mechanical			
1)	Invoice No. 21OMIDD002	O&M	\$ 3,480.55
2)	Invoice No. 21OMIDD007	O&M	\$ 562.50
3)	Invoice No. 21OMIDD009	O&M	\$ 4,961.00
4)	Invoice No. 21OMIDD011	O&M	\$ 3,099.26
5)	Invoice No. 21OMIDD013	O&M	\$ 360.00
6)	Invoice No. 22OMIDD-003	O&M	\$ 645.00
f) Hesco			
1)	Invoice No. 2213446	O&M	\$ 6,724.75
2)	Invoice No. 2213447	O&M	\$ 1,202.50
3)	Invoice No. 2213456	O&M	\$ 4,579.75
4)	Invoice No. 20212685	O&M	\$ 4,543.75
g) Metco			
1)	Invoice No. 1811-38	O&M	\$ 70,448.33
2)	Invoice No. 1811-37	O&M	\$ 84,877.13
h) Motor City Electric Company			
1)	Invoice No. 94246	O&M	\$ 189.00
2)	Invoice No. 94247	O&M	\$ 180.00
3)	Invoice No. 94264	O&M	\$ 725.64
4)	Invoice No. 94265	O&M	\$ 54.00
5)	Invoice No. 94266	O&M	\$ 63.00
6)	Invoice No. 94267	O&M	\$ 315.00
7)	Invoice No. 94319	O&M	\$ 716.64
8)	Invoice No. 94320	O&M	\$ 135.00
i) NTH Consultants, Ltd			
1)	Supplementary Support Services at NESPS Invoice No. 2	O&M	\$ 9,901.20
2)	Consulting Services for System Inspect. Invoice No. 7	O&M	\$ 7,323.35
3)	Contract No. 1 PCI-4 Invoice No. 15	NI-EA	\$ 88,099.04
4)	NI-EA – Engineering Design Services Rehabilitation of NI-EA Sections PCI-4 Invoice No. 33	NI-EA	\$ 16,596.70
5)	Eng./Consult. Services NESPS CMT		

6)	Invoice No. 15	NESPS	\$	2,078.78
7)	Rehabilitation Program 2021 Closeout Services Invoice No. 62	O&M	\$	6,455.97
j)	PMA Consultants Invoice No. 03559.01-20	NESPS	\$	15,711.73

11. Other Business

12. Adjourn

Next Regular Meeting: April 20, 2022 11:30 a.m., Eastern Standard Time.

Agenda Item No. 3

Board Meeting Minutes from February 16, 2022

**MINUTES OF THE REGULAR MEETING OF THE DRAINAGE BOARD
FOR THE OAKLAND-MACOMB INTERCEPTOR DRAIN DRAINAGE DISTRICT**

February 16, 2022

Minutes of the regular meeting of the Drainage Board of the Oakland-Macomb Interceptor Drain Drainage District held at the office of the Oakland County Water Resources Commissioner, One Public Works Drive, Building 95 West, Waterford, Michigan on the 16th day of February at 11:30 a.m. Eastern Standard Time and via Microsoft Teams.

PRESENT:

Michael Gregg, Chairperson and Deputy for Gary McDowell, Director of the Michigan Department of Agriculture and Rural Development; Brian Baker for Candice Miller, Member and Macomb County Public Works Commissioner; and Jim Nash, Secretary and Oakland County Water Resources Commissioner.

OTHERS PRESENT:

Representing the office of the Macomb County Public Works Commissioner: Stephen Downing and Norb Franz. Representing the office of the Oakland County Water Resources Commissioner: Steve Korth, Brian Coburn, Sid Lockhart, Joel Brown, Evans Bantios, Megan Koss, and Stephanie Lajdziak. Others in attendance: Brady Harrington, MDARD; John Michalski, ASI; Fritz Klingler, FK Engineering; Larry Gilbert, Saju Sachidanandan, and Michelle Kitzinger, NTH Consultants; Jeff Ragle and Shawn Phelps, OC Fiscal Services; Terry Moore, Metco; Dave Pauline, Walsh Construction

1. Call meeting to order.

Chairperson Gregg called the meeting to order at 11:30 a.m.

2. Agenda.

Motion by Baker, supported by Nash, to approve the February 16, 2022 agenda as presented.

ADOPTED: Yeas - 3
 Nays - 0

3. Minutes.

Motion by Nash, supported by Baker, to approve the minutes of the January 19, 2022 meeting.

ADOPTED: Yeas - 3
 Nays - 0

4. Public Comment.

None.

5. Memorandum Requesting Approval of the Engineering Service Agreement with Jacobs for the Design of Odor and Corrosion Control System.

Mr. Brown provided the Board with a brief overview of the Request for Proposals for the Design of an Odor and Corrosion Control System. He advised that Tetra Tech and Jacobs

both scored high. The panel agreed Jacobs was the preferred option due to previous study experience and knowledge of the system. Mr. Brown advised the design will be completed by the end of the year and further updates on the project will be available once the design is complete.

It was moved by Nash, supported by Baker, to approve the engineering services agreement with Jacobs to provide engineering services related to the Design of an Odor and Corrosion Control System as presented.

ADOPTED: Yeas - 3
Nays - 0

6. Change Order.

The following Change Orders were submitted to the Board for approval:

- a) Walsh Construction Change Order No. 19 for the NESPS Pump & Electrical Upgrades Project for a net increase in the amount of \$20,518.24. Motion by Baker, supported by Nash, to approve the Change Order as presented.

ADOPTED: Yeas - 3
Nays - 0

- b) Doetsch Industrial Services, Inc. Change Order No.4 for the OMID Immediate Repairs Project for a net decrease in the amount of \$7,435.00. Motion by Nash, supported by Baker, to approve the Change Order as presented.

ADOPTED: Yeas - 3
Nays - 0

7. Construction Pay Estimates.

The following Construction Pay Estimates were submitted to the Board for approval:

- a) Construction Estimate No. 16 for Walsh Construction for NESPS Pump & Electrical Upgrades Project (GMP Phase) in the amount of \$915,238.14 with a transfer to the Oakland County Treasurer in the amount of \$99,820.91. Motion by Baker, supported by Nash, to approve the Construction Pay Estimate as presented.

ADOPTED: Yeas - 3
Nays - 0

- b) Construction Estimate No. 11 for Marra Services for NIEA Contract No. One for PCI 4 Rehabilitation in the amount of \$558,333.90 with a transfer to the Oakland County Treasurer in the amount of \$62,037.09. Motion by Nash, supported by Baker, to approve the Construction Pay Estimate as presented.

ADOPTED: Yeas - 3
Nays - 0

8. Report/Update – Status of OMI Project, Segments 1 through 4, NESPS and NI-EA.

Fritz Klingler of FK Engineering presented the Project Progress Update to the Board and summarized the status of various projects. Motion by Nash, supported by Baker, to receive and file the report and summary.

ADOPTED: Yeas - 3
 Nays - 0

9. Financial Reports.

Shawn Phelps of OC Fiscal Services presented the financial reports for Segments 1 through 5 and the NESPS. Motion by Baker, supported by Nash, to receive and file the financial reports.

ADOPTED: Yeas - 3
 Nays - 0

10. Invoices.

The following invoices were submitted to the Board for approval:

- a) Reimbursement of Oakland County WRC-Incurred Expenses and Costs
 - 1) Labor/Fringes/Non-Direct Labor Factor
 - Segment 5 NI-EA Construction \$ 7,497.31
 - Segment 5 NESPS Mech./Elect. Construction \$ 30,119.43
 - 2) Equipment Charges
 - Segment 5 NI-EA Construction \$ 319.88
 - Segment 5 NESPS Mech./Elect. Construction \$ 2,692.89
- b) ASI, Inc.
 - 1) Invoice No. 35 NESPS \$ 80,669.03
 - 2) Invoice No. 36 NESPS \$ 75,960.15
- c) Clark Hill
 - 1) Invoice No. 1168115 NI-EA \$ 495.10
 - 2) Invoice No. 1168195 NI-EA \$ 4,770.50
 - 3) Invoice No. 1168196 O&M \$ 3,510.00
- d) CSM Mechanical
 - 1) Invoice No. NEPS Maintenance O&M \$ 1,703.00
 - 2) Invoice No. 22OMIDDD-001 O&M \$ 13,946.50
 - 3) Invoice No. 21OMIDDD-019 O&M \$ 2,160.00
 - 4) Invoice No. 21OMIDDD-017 O&M \$ 1,333.20
- e) Hesco
 - 1) Invoice No. 2213372 O&M \$ 9,609.50
 - 2) Invoice No. 2213373 O&M \$ 13,957.50
 - 3) Invoice No. 2213381 O&M \$ 5,485.00
 - 4) Invoice No. 2213371 O&M \$ 4,690.00
- f) Konecranes
 - 1) Invoice No. 154604811 O&M \$ 4,646.19
 - 2) Invoice No. 154604812 O&M \$ 9,244.90
- g) Motor City Electric Company
 - 1) Invoice No. 93771 O&M \$ 405.00
 - 2) Invoice No. 93797 O&M \$ 180.00
 - 3) Invoice No. 93798 O&M \$ 135.00

4)	Invoice No. 93800	O&M	\$	306.00
5)	Invoice No. 93801	O&M	\$	270.00
6)	Invoice No. 93802	O&M	\$	135.00
7)	Invoice No. 93803	O&M	\$	90.00
8)	Invoice No. 93804	O&M	\$	180.00
9)	Invoice No. 93952	O&M	\$	135.00
10)	Invoice No. 94001	O&M	\$	90.00
11)	Invoice No. 94002	O&M	\$	657.74
12)	Invoice No. 94003	O&M	\$	180.00
h)	NTH Consultants, Ltd			
1)	Supplementary Support Services at NESPS Invoice No. 1	O&M	\$	21,931.16
2)	Consulting Services for System Inspect. Invoice No. 6	O&M	\$	10,882.74
3)	Contract No. 1 PCI-4 Invoice No. 14	NI-EA	\$	58,988.02
4)	NI-EA – Engineering Design Services Rehabilitation of NI-EA Sections PCI-4 Invoice No. 32	NI-EA	\$	9,693.45
5)	Repairs – OMID System Immediate Repairs Invoice No. 36	O&M	\$	1,445.84
6)	Rehabilitation Program 2021 Closeout Services Invoice No. 61	O&M	\$	5,134.30
i)	Rotor Electric Company			
1)	Invoice No. 12476	O&M	\$	3,120.23
2)	Invoice No. 12477	O&M	\$	1,918.00
3)	Invoice No. 12478	O&M	\$	46,764.30
4)	Invoice No. 12479	O&M	\$	6,072.05
5)	Invoice No. 12480	O&M	\$	7,404.05

Motion by Nash, supported by Baker to approve the invoices as presented.

ADOPTED: Yeas - 3
Nays - 0

11. Other Business.

12. Adjourn.

Motion by Nash, supported by Baker, to adjourn the February 16, 2022, meeting at 12:28 p.m.

ADOPTED: Yeas - 3
Nays - 0

Next Regular Meeting: March 16, 2022 at the *Office of the Oakland County Water Resources Commissioner, One Public Works, Building 95 West, Waterford, Michigan* and electronically at 11:30 a.m., Eastern Standard Time.

I hereby certify that the foregoing constitutes the minutes of the Drainage Board for the Oakland-Macomb Interceptor Drain Drainage District, at a meeting held on February 16, 2022 and that the meeting was conducted and public notice was given in compliance with the Open Meetings Act being Act 267, Public Acts of Michigan, 1976, as amended, and that the minutes were kept and will be or have been made available to the public as required by the Act.

IN WITNESS WHEREOF, I have hereunto affixed my official signature on this 16th day of February 2022.



Jim Nash, Secretary
Oakland-Macomb Interceptor Drain Drainage Board

Agenda Item No. 4

Public Comment

Agenda Item No. 5

Budget and Flow Allocations for
Rate Year 2022/2023



Oakland-Macomb Interceptor Drain Drainage District

TO: Mike Gregg, Chairman
Oakland-Macomb Interceptor Drain Drainage District (OMIDDD)

FROM: Raphael Chirolla; Financial Services OCWRC
Bruce Manning, Financial Manager MCPWO

SUBJECT: Rate Year (RY) 2022/23 Budget Recommendation

DATE: March 16, 2022

Staff of the Macomb County Public Works Commissioner's Office and the Oakland County Water Resources Commissioner's Office recently met to discuss the budget, cost allocation, and capital improvement plan for the upcoming rate year. Staff recommends that the Board approve the proposed sewer charges contained herein for the rate year beginning July 1, 2022.

The main elements of the proposed budget and sewer charges are as follows:

- 1) The Great Lakes Water Authority (GLWA) approved a 3.2% increase in sewer charges to OMIDDD.
- 2) The proposed operation and maintenance budget includes an increase of 22.9% (see Exhibit A)
- 3) The proposed revenue requirement is increasing by 4.0%.
- 4) The method for determining the split between Oakland and Macomb was approved on March 20, 2019 and will remain in place through RY 2024/25 unless GLWA modifies the sewer charge methodology. The cost allocation using this methodology is as follows:
 - a. GLWA common-to-all and OMIDDD operations and maintenance costs are allocated based on the ten-year rolling average as shown in Exhibit B. This year's allocation is 31.77% Clinton Oakland Sewage Disposal System (COSDS) and 68.23% to the Macomb Interceptor Drain Drainage District (MIDDD).
 - b. GLWA's Combined Sewage Overflow Program is allocated 39.48% to COSDS and 60.52% to MIDDD per the 1999 Rate Settlement Agreement.
 - c. Capital Improvement Reserve contributions are allocated based on the current GLWA Contract Capacity split of 33.10% for the COSDS and 66.90% for the MIDDD.
- 5) The budget proposes to fund \$1,050,000 of new major maintenance work and \$10,782,500 of new capital improvements from the OMIDDD operation and maintenance fund, in addition to projects that are not revenue financed (see Exhibit C).

Recommended Action: Approve the proposed operating budget (Exhibit A), cost allocation (Exhibit B), and the Capital Improvement Program (Exhibit C) for the rate year beginning July 1, 2022, as presented.

Effective July 1, 2022

Exhibit A

Annual Operating Charges

	Current 2022	2023	COSDS	MIDD	Annual		Monthly	
	Budget	Budget	%	%	COSDS	Macomb	COSDS	MIDD
GLWA								
Common-to-all and OMIDDD Charges	\$ 68,038,100	\$ 70,241,700	31.77%	68.23%	\$ 22,315,788	\$ 47,925,912		
CSO Program	1,671,700	1,692,300	39.48%	60.52%	668,120	1,024,180		
Total	69,709,800	71,934,000			22,983,908	48,950,092	\$ 1,915,325.67	\$ 4,079,174.33
OMIDDD								
Operations and Maintenance Expense								
Sewer System Maintenance	1,078,400	595,360	31.77%	68.23%	189,146	406,214		
Sewer System Engineering	52,210	68,220	31.77%	68.23%	21,673	46,547		
Pump Maintenance Unit	2,191,860	2,237,780	31.77%	68.23%	710,943	1,526,837		
Systems Control Unit	260	410	31.77%	68.23%	130	280		
Mapping Unit	2,070	1,300	31.77%	68.23%	413	887		
Miss Dig	360	110	31.77%	68.23%	35	75		
General and Administrative	63,090	1,261,030	31.77%	68.23%	400,629	860,401		
Subtotal	3,388,250	4,164,210			1,322,969	2,841,241	110,247.42	236,770.08
Non Operating	-	-	31.77%	68.23%	-	-	-	-
Major Maintenance	1,150,000	1,150,000	31.77%	68.23%	365,355	784,645	30,446.25	65,387.08
Emergency Maintenance	500,000	500,000	31.77%	68.23%	158,850	341,150	13,237.50	28,429.17
Capital Improvement	802,400	800,000	33.10%	66.90%	264,800	535,200	22,066.67	44,600.00
Subtotal	2,452,400	2,450,000			789,005	1,660,995		
O&M Non-Rate Revenue	(200,420)	(210,060)	31.77%	68.23%	(66,736)	(143,324)	(5,561.33)	(11,943.67)
FY 2023 Total Fixed Charges	\$ 75,350,030	\$ 78,338,150			\$ 25,029,146	\$ 53,309,004	2,085,762.18	4,442,416.99

Capital Improvements are defined as investments that are made to assets that exceed \$5,000 and increase the useful life of assets by five years or more.

Debt Service*		
2010A mfa 5368-02	1,671,500	1,673,875
2010B	-	-
2011A mfa 5368-02	1,624,750	1,619,688
2013A mfa 5368-03	3,954,400	3,953,400
2014A	468,344	471,844
2015A mfa 2001-01	543,625	544,250
2019 refunding	437,280	445,528
2019 revenue	1,069,018	507,315
2020A	3,278,650	3,273,900
2022 Issuance Projected Debt**	392,900	887,750
Total Debt Service	13,440,466	13,377,549
Total OMIDDD Related Revenue Requirements	88,790,496	91,715,699

* Estimated annual debt service for the 2023 budget updated February 2022

** 2022 issuance projected debt for 2023 using dated date of 9/1/2022, funding of approximately \$15 million, final maturity 7/1/2042, and true interest cost of approximately 2.6%.

Oakland-Macomb Interceptor Drain Drainage District

Fiscal Year (FY) 2022/23 Budget

March 16, 2022

Effective July 1, 2022

Exhibit B

Flow Data

Year	Fiscal Year	OMID FMWG Flows		DWSD Rate Simplification Flows		OMIDDD Allocation Flows	
		COSDS (cfs)	Macomb (cfs)	COSDS (cfs)	Macomb (cfs)	COSDS (cfs)	Macomb (cfs)
1	FY2011/12	33.25	71.00	32.44	68.00	32.85	69.50
2	FY2012/13	29.89	62.82	NA	NA	29.89	62.82
3	FY2013/14	30.74	64.80	NA	NA	30.74	64.80
4	FY2014/15	29.74	64.76	NA	NA	29.74	64.76
5	FY2015/16	29.36	65.08	NA	NA	29.36	65.08
6	FY2016/17	30.63	66.50	NA	NA	30.63	66.50
7	FY2017/18	34.05	69.60	NA	NA	34.05	69.60
8	FY2018/19	34.05	69.60	NA	NA	34.05	69.60
9	FY2019/20	32.51	70.79	NA	NA	32.51	70.79
10	FY2020/21	27.02	64.16	NA	NA	27.02	64.16
Current FY2021/22 (9-Yr Average)						31.54	67.05
Current FY2021/22 Percent						31.99%	68.01%
Prop. FY2022/23 (10-Yr Average)						31.08	66.76
Prop. FY2022/23 Percent						31.77%	68.23%

1. All annual flows are based on the average monthly flow rates, proportioned based on the number of days in each month.
2. COSDS Flows for fiscal years FY2011/12 thru FY2014/15 include a 30% adjustment to account for diversion to the Clinton River Wastewater Resource Reclamation Facility (CRWRRF).
3. Due to a catastrophic failure at the CRWRRF (COSDS's non-OMID outlet), COSDS delivered more than 70% of its flow to OMID in FY2017/18. For the FY1920 calculations, the actual FY2017/18 COSDS-to-OMID flow was replaced with a COSDS-to-OMID flow adjusted to equal 70% of the total COSDS flow. The adjustment was made to reflect the intent to deliver 70% of COSDS flow and minimize rate volatility. In FY2018/19, COSDS offset the high FY2017/18 COSDS-to-OMID flow with a low FY2018/19 COSDS-to-OMID flow. With the actual flows from these two years paired, volatility is minimized and the intent to deliver 70% of COSS flow is reflected. Therefore, the FY2017/18 actual COSDS-to-OMID flow is used for the FY2020/21 calculations instead of the FY2017/18 adjusted COSDS-to-OMID flow.
4. In FY2017/18 and FY2018/19, there was volatility in the flow delivered from COSDS to OMID (see note 3 for details). When paired, these two years offset each other and the volatility is mitigated. The OMID rates are based on a rolling 9-year average flow rate. In Rate Years 2829 and 2930, these volatile years will roll off the average, which will create volatility in the average. To reduce this future volatility, the COSDS-to-OMID flows and MIDDD flows for FY2017/18 (COSDS = 37.74 cfs, MIDDD = 67.29 cfs) and FY2018/19 (COSDS = 30.35 cfs, MIDDD = 71.90 cfs) have both been replaced with the average for these two years (COSDS = 34.045 cfs, Macomb = 69.595 cfs).
5. Except as noted above, COSDS fiscal year flows are based on measured flow, which includes actual diversion to CRWRRF.

EXHIBIT C
OAKLAND MACOMB INTERCEPTOR DRAIN DRAINAGE DISTRICT
CAPITAL IMPROVEMENT PROGRAM
February 11, 2022

Maintenance Reserve (Fund 82912)

Project No.	Project Description	2021 Actual	2022 Updated	2023 Proposed
	MAINTENANCE RESERVE BALANCE BEGIN OF YEAR	\$2,848,992	\$1,808,945	\$1,628,945
	Total Maintenance Reserve Revenue	\$1,037,500	\$1,150,000	\$1,150,000
1-2842	NESPS Operational Transition (Includes NEXGEN AM)	\$47,829	\$60,000	\$0
1-3014	NESPS Emergency Contingencies Project	\$188,690	\$70,000	\$0
1-3015	OMID Immediate Repairs Project	\$1,432,617	\$150,000	\$0
1-3275	OMID Odor-Corrosion Study 2	\$201,580		
N/A	Major Maintenance General	\$204,892		
N/A	P4 VFD Replacement		\$300,000	\$300,000
N/A	CCTV Inspection	\$1,940	\$250,000	\$250,000
N/A	PLC Replacement at NESPS Generator		\$0	\$0
NEW	Wet Well Cleaning-Check (Note 2021 in Immediate Repairs)		\$500,000	\$500,000
	Total Maintenance Reserve Expenses	\$2,077,548	\$1,330,000	\$1,050,000
	MAINTENANCE RESERVE BALANCE END OF YEAR	\$1,808,945	\$1,628,945	\$1,728,945

Capital Reserve (Fund 82912)

Project No.	Project Description	2021 Actual	2022 Updated	2023 Proposed
	Total Capital Reserve Revenue	\$1,082,984	\$802,400	\$800,000
1-3016	OMID Flow Control Improvements (Gates)	-\$10,988	\$400,000	\$5,600,000
1-3017	NESPS Security Upgrades	\$1,735		
1-3018	OMID NESPS Elevator	\$218,801		
1-3019	OMID NIEA Sewer Rehabilitation Design	\$81,216	-\$2,236,912.57	\$0
1-3020	NESPS Mechanical and Electrical Upgr/Design	-\$83,655	-\$3,905,971.57	\$0
N/A	Capital General	\$1,756		
XX	ITC Bypass			\$1,000,000
XX	NESPS Discharge Chamber Correction		\$500,000	\$1,500,000
XX	OMID Odor and Corrosion Facility Design		\$700,000	\$300,000
XX	NESPS Wet Well Heaters		\$275,000	\$300,000
N/A	OMID PCI-7 Bypass Feasibility Analysis		\$0	\$450,000
N/A	Pipe Lining PCI-7		\$0	\$500,000
N/A	Hydrogen Sulfide Mitigation in OMID/NI-EA		\$500,000	\$500,000
NEW	MIDDD Segment 5-OMID Portion		\$0	\$562,500
NEW	Macomb SCADA Upgrades OMIDDD Portion		\$0	\$70,000
	Total Capital Reserve Expense	\$208,865	-\$3,767,884	\$10,782,500
	CAPITAL RESERVE BALANCE	\$3,287,994	\$7,858,278	-\$2,124,222

Emergency Maintenance (Fund 82912)

Project No.	Project Description	2021 Actual	2022 Updated	2023 Proposed
	Total Emergency Reserve Revenue	\$500,000	\$500,000	\$500,000
	No Planned Work			
	Total Emergency Reserve Expenses	\$0	\$0	\$0
	Ending Emergency Reserve Balance	\$1,500,000	\$2,000,000	\$2,500,000

Summary of Reserve Balances (Fund 82912)

Reserve	2021 Actual	2022 Updated	2023 Proposed
Undesignated	\$7,804,956	\$7,804,956	\$7,804,956
Major Maintenance	\$1,808,945	\$1,628,945	\$1,728,945
Emergency Maintenance	\$1,500,000	\$2,000,000	\$2,500,000
Capital	\$3,287,994	\$7,858,278	-\$2,124,222
Net Position	\$14,401,894	\$19,292,179	\$9,909,679
<i>12.5% of the Operations and Maintenance Budget</i>		\$9,137,256	\$9,466,933

Current Construction Funds 2/11/22

Project No.	Project Description	Funds Committed for Capital Projects (In-progress)
1-3308	NESPS Mechanical and Electrical Construction	\$54,086,000
1-3309	NIEA Phase I First Bond	\$28,395,600
Total Remaining Expense in Construction Funds		\$82,481,600

Future Bonded Projects Through 2023

Project No.	Project Description	Project Estimate
NEW	NIEA Phase II Bond	\$15,000,000
NEW	OMID Odor/Corrosion Facility Construction	\$9,000,000
Total Bonded Projects		\$24,000,000

Agenda Item No. 6

Change Orders

CHANGE ORDER NO. TWENTY

Oakland Macomb Interceptor Drain, Drainage District (OMIDDD)

For Construction of the Pump and Electrical Upgrades Project

Northeast Sewage Pumping Station (NESPS)

Located in the City of Detroit, Wayne County, Michigan

**CONSTRUCTION MANAGER,
AT RISK (CMAR)
Walsh Construction Co. II, LLC**

Authorization for:

- 1.) Modifications to the existing NESPS Gatehouse Pump Discharge Riser Cover Plates to provide for surface access.

Address:

Walsh Construction Co. II LLC
3031 West Grand Blvd., Suite 640
Detroit, MI 48202

Change Order No. 20 Date: March 04, 2022

	Location-Description-Reason	Unit	Est. Quant.	Unit Price	Amount Increase	Amount Decrease
20 -1	<p><u>LOCATION:</u></p> <p>The Northeast Sewage Pumping Station; Detroit, Wayne County, Michigan</p> <hr/> <p><u>DESCRIPTION (Extra/ Add):</u></p> <p>Furnish labor, material, and equipment to perform shop and field modifications to each of the twelve existing NESPS Gatehouse Chamber Pump Discharge "Riser Cover Plates" to provide a means for manned access from the ground surface..</p> <p><u>REASON:</u></p> <p>The existing pump discharge risers were installed in conjunction with the previous Gatehouse Emergency Repair Project as a means to provide full discharge conveyance from the main sewage pumps, as well as ventilation and air relief for the system. The risers were originally provided with a welded end cap at finish grade that was considered as an interim measure pending final construction of the overall NESPS air quality improvement project (referred to as the Odor and Corrosion Control Project).</p>	LS	1 ea.	\$215,255.18	\$215,255.18	-0-

OMID DD NESPS; Pump & Electrical Upgrades Project; C.O. # 20

	Location-Description-Reason	Unit	Est. Quant.	Unit Price	Amount Increase	Amount Decrease
20 -1	<p>Upon completion of that project, and with the current identified need to provide a means of access into the individual risers to address upgrades to the existing internal deteriorated coating system, a revised riser end cap entry detail was developed.</p> <p>The proposed "flanged entry" detail will allow for both planned riser lining upgrades to be completed as well as provide for simplified future maintenance access to each of the individual risers, when needed.</p> <p>In addition, the new riser cover plates will each be equipped with small diameter (8") inspection ports to allow the insertion of a video camera into each riser for routine condition assessment tasks.</p> <p>Attachment: Walsh PCI No.970113, Rev. 02</p> <p align="center">*****</p> <p align="center">End of Change Order No. 20 Line Items</p>					
					Amount Increase	Amount Decrease
	Totals	\$215,255.18	-0-		Net Changes (Increase)	\$215,255.18

OMID DD NESPS; Pump & Electrical Upgrades Project; C.O. # 20

Prepared By: James S. Gilbert Date: 03-09-2022
Lawrence T. Gilbert, P.E.
NTH Consultants, Ltd.

Recommended By: [Signature] Date: 3/9/2022
John Michalski, P.E.
Engineer of Design, Applied Science, Inc.

Approved By: Joel Brown Date: 3/11/2022
Joel Brown, P.E.
Project Manager, WRC

Approved By: Stephen Downing Date: 3/11/2022
Stephen Downing
Construction and Maintenance Manager, Macomb County Public Works

Approved By: [Signature] Date: 3/11/2022
Sid Lockhart, P.E.
Manager of Special Projects, WRC

Approved by: _____ Date: _____
Steve Korth, P.E.
Manager, WRC

All of Construction Manager's contractual obligations remain in place and are applicable to all work and payments identified herein. No adjustment to contract time or price shall be made for these issues except as set out in this, or by a subsequent related, Change Order.

The Construction Manager agrees to do the work described above and agrees to accept Contract time adjustments in full on the basis indicated.

Accepted by: DocuSigned by: [Signature] Date Mar-09-2022 | 8:25 AM CST
588F73D8A99D45 Vice President
Title
of: Walsh Construction Co. II, Inc.

The Construction Manager is hereby authorized and instructed to do the Work described above in accordance with the terms of the Contract, as amended.

This Change Order No. 20 was approved by the Drainage Board on: Date: _____

Attachment No. 1 to Change Order No. Twenty

The Engineer has reviewed the items included in this Change Order and confirms that these adjustments to the Contract are reasonable and in accordance with industry standards and the requirements of the Contract.

Contract Status Summary
Change Order No. Twenty
OMID NESPS Pump & Electrical Upgrades Project

Construction Manager at Risk: Walsh Construction Co. II

Project Award Date (Pre-Construction Services)	December 16, 2019
Notice to Proceed Date (Construction Phase)	October 23, 2020
Contract Substantial Completion Date	March 24, 2023
Contract Final Completion Date	June 23, 2023
Original GMP Contract Value (Including Control Structure 9)	\$ 42,863,185.19
Pre-Construction Phase, Unused Budget	\$ 70,196.70
Prev. C.O. Values, # 7, 8, 9, 10, 11, 12, 13, 14, 15,16, 17,18, & 20	\$ 2,005,035.45
Change Order Value, this C.O. # 20	\$ 215,255.18
<i>Adjusted GMP Contract Value (incl. this C.O. # 20)</i>	\$ 45,153,672.52

CHANGE ORDER NO. TWO

NIEA OMID Contract One, PCI-4 Rehabilitation
Oakland Macomb Interceptor Drain, Drainage District (OMIDDD)
For Lining of the PCI-4 Interceptor and Access Structure Construction

Located in the City of Detroit, Wayne County, Michigan

Authorization for:

- 1.) Modifications to Project Laydown Yard and Site entrance improvements; 2.) Adjustments to the Contract Times resulting from increased flow control delay times resulting from various OMID operational requirements; 3.) Additional costs resulting from repairs to the DWSD Outer Drive Sewer resulting from Dewatering System Construction.

CONTRACTOR:

: **Marra Services, Inc.**

 700 East 73 rd. Street

 Cleveland, OH 44103

Date: February 14, 2022

No.	Location-Description-Reason	Unit	Est. Quant.	Unit Price	Amount Increase	Amount Decrease
	<p><u>LOCATION:</u></p> <p>This reach of the PCI-4 Interceptor Sewer is located beneath segments of the Northeast Sewage Pump Station (NESPS) campus, and the East State Fair Ave, Conner Ave., and East Outer Drive Ave. thoroughfares in the City of Detroit, MI. . The Project Laydown yard is located on GLWA property adjacent to the NESPS facility, north of State Fair Ave.</p>					
2-1	<p><u>DESCRIPTION: (Add/ Extra):</u></p> <p>Modify the proposed Construction Laydown area to provide an alternative site entrance location, temporary gate and fence line alterations, and entrance roadway improvements.</p>	1	LS	\$49,520.20	\$49,520.20	-0-

NIEA OMID Contract One, PCI-4 Rehabilitation; C.O. # 2

No.	Location-Description-Reason	Unit	Est. Quant.	Unit Price	Amount Increase	Amount Decrease						
2-1	<p><u>REASON:</u></p> <p>Provisions in the Contract require the construction of a short driveway entrance into the proposed NIEA Contract 1 laydown area. This site is located on vacant property owned by the GLWA and was made available for material storage following an agreement with GLWA for temporary use that also included additional provisions for protection of existing GLWA underground facilities.</p> <p>The Contract plans for the entrance road provided for an entrance location within the NESPS Pump & Electrical Rehabilitation project site and utilized the main NESPS site entrance roadway as a means of access to the proposed NIEA C-1 laydown yard. This access route was deemed objectionable to the NESPS project management for reasons of potential construction traffic congestion and site security. Accordingly, an alternative entrance road location was devised to alleviate these problems.</p> <p>This optional arrangement required additional access road improvements and repair and realignment of existing site fencing. Additionally, GLWA requested that several temporary protective devices (construction fencing and steel road plate crossings) be provided to ensure the security of the major underground water line within the laydown area perimeter.</p> <p>The construction cost for this additional effort was partially offset by the credit due for the deletion of the original site entrance. In addition, the acquisition of the steel road plates (\$13,713.38) for GLWA water main protection will become the property of the OMID DD and available for future re-use.</p> <p>Cost Summary:</p> <table border="0"> <tr> <td>New Entry Construction:</td> <td align="right">\$55,959.83</td> </tr> <tr> <td>Credit for Deleted Work</td> <td align="right">(\$ 6,439.63)</td> </tr> <tr> <td>Total Cost, New Site Entry</td> <td align="right">\$49,520.52</td> </tr> </table> <p>Attachment: Cost Documentation; Marra Services</p>	New Entry Construction:	\$55,959.83	Credit for Deleted Work	(\$ 6,439.63)	Total Cost, New Site Entry	\$49,520.52					
New Entry Construction:	\$55,959.83											
Credit for Deleted Work	(\$ 6,439.63)											
Total Cost, New Site Entry	\$49,520.52											
2-2	<p><u>DESCRIPTION (Change/ Add):</u></p> <p>Adjust the Contract Time to reflect the increase in anticipated Flow Management delay days due to the operational requirements of the NESPS and the overall OMID system, and provide compensation for the costs resulting from these delays.</p>	<p>Days (Cal)</p> <p>LS</p>	<p>67 ea.</p> <p>1 ea.</p>	<p>-0-</p> <p>\$88,000.00</p>	<p>67 Days (Cal.)</p> <p>\$88,000.00</p>	<p>-0-</p> <p>-0-</p>						

NIEA OMID Contract One, PCI-4 Rehabilitation; C.O. # 2

No.	Location-Description-Reason	Unit	Est. Quant.	Unit Price	Amount Increase	Amount Decrease
2-2	<p><u>REASON:</u></p> <p>The Contract Specifications indicate that the Contractor should anticipate an overall period of 30 days where work within the PCI-4 Interceptor will not be available due to circumstances occurring elsewhere in the system.</p> <p>These circumstances may include operational issues at the NESPS or elsewhere in the OMID system, as well as the need to grant flow control priority to other active OMID Contracts, thereby preventing the NIEA C-1 Contract from manned work in the interceptor.</p> <p>An initial evaluation period was selected based on the key milestone activity of temporary support rib installation in the interceptor at the Access Structure Location. This period extended from June 21,2021 to November 05, 2021, and during that period the project experienced a total of 44 documented delay dues attributable to OMID Operational issues.</p> <p>This significant increase in the anticipated number of operational days was largely the result of two major downtime events at the NESPS that were not anticipated in the original 30 Operational Day projection. During this period, the Contractor also experienced continuing costs resulting from idled equipment and site-related general conditions costs.</p> <p>Following extended negotiations with the Contractor, it was concluded that the best interests of the project would be served to address these delay times and resulting costs for the period indicated, and move forward with a Contract adjustment that included the following issues:</p> <ul style="list-style-type: none"> • A thirty day period "re-established" for future Operational Delays, • The additional 14 delay days beyond the initial 30 day Contract operational delay day period, and • The overall costs attributable to this delay being brought into full resolution. The total adjustment to the Contract Time is accordingly 44 work days with the equivalent of \$2.000/ work-day <p>The cost for these delays was calculated at \$2,000 per delay-work day, and was based on idled equipment and continuing identifiable general conditions costs experienced by the Contractor.</p>					

NIEA OMID Contract One, PCI-4 Rehabilitation; C.O. # 2

No.	Location-Description-Reason	Unit	Est. Quant.	Unit Price	Amount Increase	Amount Decrease
2-2	<p>SUMMARY:</p> <p>A.) Adjustment to the Contract Time (44 work days, equal to 67 calendar days equal to an adjusted Substantial Completion date of December 02, 2022</p> <p>B.) Adjustment to the Contract Value (44 days at \$2,000 per cal. day, with LS value = \$88,000.00</p> <p>Attachment: Marra Services Cost Documentation</p>					
2-3	<p><u>DESCRIPTION (Extra/ Add):</u></p> <p>Provide compensation for repairs to the DWSD Outer Drive Storm Sewer resulting from damages incurred during installation of the Outer Drive Access Shaft Dewatering System.</p> <p><u>REASON:</u></p> <p>The installation of individual deep wells for the Access Shaft Ejector dewatering system resulted in inadvertent damage to the concrete secondary lining of a discrete section of the DWSD Outer Drive sewer. Despite significant precautions in advance to avoid contact with the sewer, the depth and imprecise sewer alignment combined with drill hole variations resulted in one borehole contacting the sewer. Repairs to the sewer interior by manned entry as well as additional efforts to stabilize the exterior surface through bore hole cementitious stabilization were completed.</p> <p>This task was determined to be the result of an unanticipated physical site condition, and compensation for the repairs was considered justified.</p> <p>Attachment: Marra Services Cost Documentation</p> <p align="center">*****</p> <p align="center">END OF CHANGE ORDER NO. TWO LINE ITEMS</p>	LS	1 ea.	\$6,286.68	\$6,286.68	-0-

NIEA OMID Contract One, PCI-4 Rehabilitation; C.O. # 2

No.	Location-Description-Reason	Unit	Est. Quant.	Unit Price	Amount Increase	Amount Decrease
Totals					\$143,806.88	-0-
Net Change Cost (Add)					\$143,806.88	-0-
Change (Time- Add)					+67 Days	

END OF CHANGE ORDER NO. TWO (NIEA OMID C-1), LINE ITEM DESCRIPTIONS

NIEA OMID Contract One, PCI-4 Rehabilitation; C.O. # 2

Prepared By:
Lawrence T. Gilbert, P.E.
NTH Consultants, Ltd.

Lawrence T. Gilbert

Date: 3-10-2022

Recommended By:
Saju Sachidanandan, P.E.
Engineer of Design, NTH Consultants, Ltd.

Saju Sachidanandan

Date: 3/10/2022

Approved By:
Joel Brown, P.E.
Project Manager, WRC

Joel Brown

Date: 3/11/2022

Approved By:
Stephen Downing
Construction and Maintenance Manager, Macomb County Public Works

Stephen Downing

Date: 3/11/2022

Approved By:
Sid Lockhart, P.E.
Manager of Special Projects, WRC

Date: _____

Approved by:
Steve Korth, P.E.
Manager, WRC

Date: _____

All of Contractor's contractual obligations remain in place and are applicable to all work and payments identified herein. No adjustment to contract time or price shall be made for these issues except as set out in this, or by a subsequent related, Change Order.

The Contractor agrees to do the work described above and agrees to accept Contract time adjustments in full on the basis indicated.

Accepted by:

Chris Koepf

*Chris Koepf, Project
Manager*

Date: 3/10/2022

of: MARRA SERVICES, INC..

The Contractor is hereby authorized and instructed to do the Work described above in accordance with the terms of the Contract, as amended.

This Change Order No. 2 was approved by the Drainage Board on: Date: _____

NIEA OMID Contract One, PCI-4 Rehabilitation; C.O. # 2

Attachment No. 1 to Change Order No. Two

The Engineer has reviewed the items included in this Change Order and confirms that these adjustments to the Contract are reasonable and in accordance with industry standards and the requirements of the Contract.

Contract Status Summary
Change Order No. Two

NIEA OMID CONTRACT ONE, PCI-4 REHABILITATION
January 18, 2022

Contractor: Marra Services, Inc.

Project Award Date	January 21, 2021
Notice to Proceed Date	February 16, 2021
Contract Substantial Completion Date (Adjusted by C.O. 1)	September 29, 2022
Contract Final Completion Date (Adjusted by C.O. 1)	October 29, 2022
Original Contract Value	\$ 14,732,510.00
Previous Change Order Values (C.O. # 1)	\$ 664,392.00
Change Order Value, this C.O. # 2	\$ 143,806.88
<i>Adjusted Contract Value, including C.O. # 2 :</i>	\$ 15,540,708.88

Agenda Item No. 7

Construction Estimates

OAKLAND MACOMB INTERCEPTOR DRAIN DRAINAGE BOARD
Northeast Sewage Pumping Station- Pump and Electrical Upgrades Project
Located in the City of Detroit, Wayne County, Michigan

Regular Construction Estimate No. SEVENTEEN
Page One of Two

February 01, 2022 through February 28, 2022

Department No.:	6010101	Account No.:	731472
Fund No.:	84917	Program No.:	149015
Project No.:	1-3309	Activity:	FAC

Construction Manager at Risk:	Vendor # 23191	LI 43331; exp. 12/16/22	
Walsh Construction Co.		Date of Contract:	Dec. 16, 2019
3031 West Grand Boulevard, Suite 640		Final Completion Date:	July 28, 2023
Detroit, MI 48202	Contract No. 5977		

Orig. GMP amount for Pump & Elec. Upgrades Project, not including CS-9 and Pre-Const. Balance	\$44,107,745.18
Expended Pre-Construction Phase Amount	(\$1,174,363.30)
<i>Unused Pre-Construction Phase Budget</i>	(\$70,196.70)
<i>CS-9 Budget from GMP</i>	(\$3,251,117.72)
NESPS Pump & Elec. Upgrades Original Contract Budget	\$39,612,067.46
Change Orders, This Estimate: C.O. No. 19	\$20,518.24
Previous C.O.s: (C.O.# 7, 8, 9, 10, 11,12, 13, 14, 15, 16, 17,and 18)- <i>Corrected Value</i>	\$1,984,517.21
Unused Pre-Construction Phase Budget	\$70,196.70
Adjusted Construction Contract Amount:	\$41,687,299.61
<hr/>	
Sub-Total To Date: (CS-9 Costs are Not included on this Estimate)	\$19,553,495.23
Less Deductions:	None
Gross Estimate: (Work in Place) Complete = 47.0%	\$19,553,495.23
Less Amount Reserved (Incl. Partial Subcon. Reductions - See Schedule)	\$1,827,821.99
Total Amount Allowed To Date:	\$17,725,673.24
Less Previous Estimates:	\$17,701,025.77
Current Payment Due	\$24,647.47
Reserve Pay to Contractor:	
Balance to Finish: \$ 22,133,804.38	Accounting Auditor:
<hr/>	
Amount To Be Reserved (From Above):)	\$1,827,821.99
Less Previous Transfers To Reserve (N/I CS-9 Contract Retention)	\$1,891,708.31
Amount of Current Transfer (Partial Retainage Overpayment by Contractor; App. # 16)	(\$63,886.32)

OAKLAND MACOMB INTERCEPTOR DRAIN DRAINAGE BOARD
Northeast Sewage Pumping Station- Pump and Electrical Upgrades Project
Located in the City of Detroit, Wayne County, Michigan
Walsh Construction Co. II; Construction Manager at Risk

Regular Construction Estimate No. Seventeen
Page Two of Two

1/01/ 2022 through 1/31/ 2022

Prepared by: Lawrence T. Gilbert

Date: 03-09-2022

Lawrence T. Gilbert, P.E.; NTH Consultants Ltd.

Recommended by: John Michalski

Date: 3/10/2022

John Michalski, P.E., ASI

Recommended by: Joel Brown

Date: 3/11/2022

Joel Brown, P.E. Oakland County WRC

Recommended by: Stephen Downing

Date: 3/11/2022

Stephen Downing; Macomb County OPWC

Approved for Payment by: Sid Lockhart

Date: 3/11/2022

Sid Lockhart, P.E.; Special Projects Manager, Oakland County WRC

Regular Construction Estimate No. 16 (January, 2022)

Approved By Board On: _____

OAKLAND MACOMB INTERCEPTOR DRAIN DRAINAGE BOARD
For Construction of the Control Structure 9 Gate Installation
Located in the City of Warren, Macomb County, Michigan
Project ID 1-3308

Application No.12 (12/01/21 to 2/31/22; Three Month Period)

Department No.:	6010101	Account No.:	730352
Fund No.:	84917	Program No.:	149015
Project No.:	514263	Activity:	FAC

Construction Manager at Risk, Walsh Construction Co. 3031 West Grand Boulevard, Suite 640 Detroit, MI 48202	Vendor # 23191	LI 43331; exp. 12/16/22	Date of Contract: Dec. 16, 2019
			Final Completion Date: July 28, 2023
	Contract No. 5977		

Original Construction Contract Amount: (CS-9 Gate Gate Installation)	\$3,251,117.72
Previous Change Orders: C.O. # 9-1, 9-2, #2, #3 and 11-7 (Including CO-11, Item 7 ; \$4,717.51)	\$63,100.29
Change Orders This Estimate: None	\$0.00
Total Net Change Orders:	\$63,100.29
Adjusted Contract Amount:	\$3,314,218.01
Sub-Total To Date: (CS-9 Charges only are included on this Estimate)	\$3,258,292.25
Less Deductions:	None
Gross Estimate: (Work in Place) 98% Complete	\$3,258,292.25
Less Amount Reserved: L.S. Value, with partial subcon. Reductions- See Schedule)	\$122,530.96
Total Amount Allowed To Date:	\$3,135,761.29
Less Previous Estimates: Paid under CS-9, App # 10	\$3,087,132.29
Net Pay Request To Be Paid To Contractor:	\$0.00
Reserve Payment to Contractor:	\$48,629.00
Balance to finish: \$55,925.76	Accounting Auditor:
Reserve Payment	\$122,530.96
Less Previous Transfers To Reserve:	\$171,159.96
Amount of Current Transfer: Retention Reduction Paid to Contractor	\$48,629.00

Prepared by: *Lawrence T. Gilbert*
 Lawrence T. Gilbert, P.E.; NTH Consultants Ltd.

Date: 3-9-2022

Recommended by: *Saju Sachidanandan*
 Saju Sachidanandan, P. E.

Date: 3/9/2022

Recommended by: *Joel Brown*
 Joel Brown, P.E. Oakland County WRC

Date: _____

Recommended by: *Stephen Downing*
 Stephen Downing; Macomb County OPWC

Date: 3/11/2022

Approved for Payment by: *Sid Lockhart*
 Sid Lockhart, P.E.; Special Projects Manager, Oakland County WRC

Date: 3/11/2022

OAKLAND MACOMB INTERCEPTOR DRAIN DRAINAGE BOARD
For Construction of the NI-EA OMID Contract 1 - PCI 4 Rehabilitation
Located in the City of Detroit, Wayne, Michigan
Project ID 1-00000003308

Regular Construction Estimate No. 12

Period: 2/01/22 through 2/28/22

Department No.:	6010101	Account No.:	731472
Fund No.:	84917	Program No.:	149015
Project No.:	100000003308	Activity:	FAC

Contractor:	Vendor # 29656 Contract # 6323	Date of Contract:	January 21, 2021
Marra Services, Inc.	LI # 44838 exp. 1/20/23	Final Completion Date:	September 9, 2022
700 E. 73 rd. Street			
Cleveland, OH 44103			

Original Construction Contract Amount	\$14,732,510.00
Previous Change Orders: No. One	\$664,392.00
Change Orders This Estimate: None	\$0.00
Total Net Change Orders:	\$664,392.00
Adjusted Contract Amount:	\$15,396,902.00
Sub-Total To Date	\$7,234,266.20
Less Deductions: None	\$0.00
Gross Estimate, Work in Place (46.98% Complete)	\$7,234,266.20
Less Amount Reserved (10%)	\$723,426.62
Total Amount Allowed To Date:	\$6,510,838.58
Less Previous Estimates	\$6,334,971.98
Net Payment Request To Be Paid To Contractor:	\$175,867.60
Reserve Payment to Contractor:	\$0.00
Balance to Finish: \$8,162,635.80	Accounting Auditor: <i>Jeff Ragle</i>
Amount to be Reserved from Above	\$723,426.62
Less Previous Transfers To Reserve:	\$703,885.77
Amount of Current Transfer	\$19,543.85

Prepared by: *Lawrence T. Gilbert*
 Lawrence T. Gilbert, P.E.; NTH Consultants Ltd.

Date: 03-09-2022

Recommended by: *Saju Sachi / AYA*
 Saju Sachidanandan, P. E.; NTH Consultants Ltd.

Date: 3/10/2022

Recommended by: *Joel Brown*
 Joel Brown, P.E. Oakland County WRC

Date: 3/11/2022

Recommended by: *Stephen Downing*
 Stephen Downing; Macomb County OPWC

Date: 3/11/2022

Approved for Payment by: *Sid Lockhart*
 Sid Lockhart, P.E.; Special Projects Manager, Oakland County WRC

Date: 3/11/2022

Agenda Item No. 8

Report/Update – Status of OMID
Project, Segments 1 through 4, NESPS,
NI-EA

Oakland Macomb Interceptor Drain (OMID) Repairs Project Progress Update

Prepared by:

F. Klingler, P.E., B. Kelly, P.E., FK Engineering Assoc.
S. Sachidanandan, P.E., L. Gilbert, P.E., NTH Consultants, Ltd.
J. Michalski, P.E., Applied Science, Inc.; T. Moore, Metco Services, Inc.
J. Matteo, P.E., Jacobs Engineering, Inc.

March 16, 2022 OMIDDD Board Meeting

The following provides a status update as of the writing of this report (March 7, 2022) for the work completed for the Oakland-Macomb Interceptor Drain Repair Program (SRF Segments 1-4; Contract 7 PCI-4 repairs; Maintenance Repairs in PCI-5 through PCI-11A; Control Structure Modifications; NIEA Repairs; NESPS Upgrades; Odor/ Corrosion Control System, and other related work):

SRF Segment 1 Status:

Contracts 1&2: Complete

System-wide Odor/Corrosion Study – Contract Extended to 5/15/2022

Engineering Consultant: Jacobs

Project Budget Summary (including EWOs):

- | | |
|---|--------------|
| • Adjusted Project Budget (including EWOs and Fan Testing Allowance): | \$567,447.00 |
| • Total Spent (through May 2021): | \$566,441.58 |
| • Additional Data Gathering Budget Expenditure to date: | \$ 0.00 |

Status of Major Project Tasks:

- System-wide Odor/Corrosion Study and additional requested work is substantially complete. Jacobs delivered on May 28, 2021 a draft technical memorandum that summarizes the NI-EA Phase 1 odor sampling recently performed at the NESPS and in PCI-4. Jacobs is currently performing additional data gathering (H2S and pressure readings) within the NIEA and OMID portions of the system to further evaluate impacts from flow control sequencing. Final Report will be updated to reflect new data.

SRF Segment 2 Status:

Contract 3 (Base Contract & C.O. 2E-2J): Complete

SRF Segment 3 Status:

Contract 4: Complete

March 16, 2022 OMIDDD Board Meeting

SRF Segment 4 Status:

Contract 5A/5B: Complete

- City of Utica Use Agreement for access paths is pending; awaiting final authorization.

Contract 6: Complete

Contract 7 (NIEA 110 feet of Emergency Rehab) – Complete

Deterioration was noted in early 2021; also see NIEA Contract 1 Summary. Following several manned inspections, report from the manufacturer's representatives has now been received and reviewed by the Engineering Team. Final conclusions remain pending; however, the consensus of the engineering team is that this lining material may not be appropriate in the extreme H₂S concentrations experienced at the Gatehouse location, and potentially other atypical locations in the interceptor. This initial section of PCI-4 is currently planned for re-lining (using GFRPMP) under NIEA OMID Contract 1 (PCI-4 Rehabilitation).

NESPS Odor/Corrosion Control System (No Segment or Contract No.): Construction Complete

NESPS & OMID Maintenance & Repairs Status:

Amt Invoiced: \$199,701 thru July, 2021 out of current \$353,000 ASI engineering budget; Does not include Metco budget for ongoing flow control, maintenance, and coordination.

Schedule Status: Ongoing

Status of Emergency Contingency Plan for pumping during total power loss or other catastrophic system failure:

- Mersino Dewatering is under contract for standby emergency bypass pumping.
- The OMIDDD Project Team is currently designing an approach for keeping the 15 Mile Road bypass pumping arrangement intact. Plans are now in place for demobilization of the pumping and support equipment, with the bypass piping remaining on site pending final decisions on a potential permanent installation.
- Remaining items in the final emergency plan include punch-list and optimization steps for electrification, the modification of one manhole, modifications at the 15-Mile Road Site, and overall optimization of the Emergency Plan per above.

March 16, 2022 OMIDDD Board Meeting

Additional work being performed under Metco Maintenance Contract for NESPS:

- Flow control operations related to OMID/MID/NIEA sewer repair and upgrade projects are ongoing.
- Mechanical and Electrical corrective/preventative maintenance schedules continue.
- Coordination between GLWA, MID, NESPS, and Pump/Electrical Upgrade Project has not affected station operations nor hindered performance or abilities to meet demands.
- Wet well sediment inspection and barscreen cleaning took place Jan 21, 2022. Very minor changes since last inspection about 8 weeks before. Sediment levels averages slightly over 4.5 feet. Bar screens remain clear of blockages. Complete report on file. Following discussions of the design team, further inspections will resume on a quarterly basis, based on report history. Sediment level has plateaued and, in some cases, dropped. Bar screens will be monitored and cleaned on an as-needed basis.
- The OMIDDD Project Team continues to research methods for using high pressure water onsite for bar screen cleaning. National Liquid Blasting has now submitted a Proposal for a “Proof of Concept” approach to the cleaning methodology, and it is under review by the Team members.
- NESPS Health and Safety Plan finalized.

Overall Station Performance Report:

- Sanitary Pumps #2 #4, #5, and #6 ready for duty with no issues to report, excepting #2 (see below). Total pump capacity equals 500-cfs (including Pump 2).
- Sanitary Pump #2 VFD (Variable Frequency Drive) enclosure has multiple issues. (1) HVAC Fan Motor failure on two of the four Bard AC units. (2) One of the three VFD cell cabinet exhaust blowers seized. Parts availability impacts both scenarios. HVAC contractor (Dunbar Mechanical) along with Rotor are working toward resolve. The pump can be used in case of emergency as the VFD Drive has internal protections to trip or shut-down in overheated conditions. Extra precautions are taken to keep pump out of rotation until issues are resolved. In any case, pump is available for use if necessary.
- Specific data logging software has been installed within the VFD drive PLC. Siemens maintains the ability to monitor VFD performance and fault/trip conditions.
- Sanitary Pump #1 remains out of service as part of the upgrade project. The Pump #1 knife gate valve has been removed under flow control. It is flanged off with no leaks. The knife gate has been refurbished and is being shipped back to the site for re-installation (see NESPS Rehab Report below)
- New transformer (T3) has been energized and tied to the existing switchgear. Station now in preferred “double ended status whereby T3 and T4 utility transformers are both under load conditions.
- NEXGEN asset management in use.
- Gas detection faults/alarms have been investigated by contractor and reviewed by the OMID team in both dry and wet wells. Protocols related to alarming have been modified by OMIDDD.
- NESPS HVAC system performing as designed after two failed components were replaced by Dunbar Mechanical.

March 16, 2022 OMIDDD Board Meeting

- Bio Filter performance normal with no odor complaints or issues to report. Parameters checked daily and shared with Bio Aire on a weekly basis.
- Overall General Housekeeping tasks in order. Minor maintenance activities addressed in a timely manner.

Control Structures Performance Report (CS-5, CS-6, CS-7, CS-8):

- Daily flow control operations now support MID/OMID/NIEA repair and improvement projects.
- All LOTO protocols are in-place with no major issues to report.
- System-wide communications are good.
- CS-6 gate remains out of service.
- Preventative maintenance tasks are underway. Emergency inspections (to confirm no similar damage as the CS-6 event) are complete at each OMID Control Structure sites. (CS-5, CS-6, CS-7 and CS-8). All inspections and preventative maintenance are complete. Minor issues addressed. Reports are on file. Corrective work orders have been generated in NEXGEN.
- CS-7 in stand-by mode ready for service.
- CS-8 in stand-by mode ready for service.
- CS-5 in stand-by mode ready for service.
- CS-9 in stand-by mode ready for service.
- PCI-5 Hobas lining repair scheduled for upcoming spring.
- Routine daily rounds and inspection made with no major maintenance issues to report at this time.

Other System Operation Issues

- O&M Manual currently being revised to include new structures, recently modified structures, new monitoring equipment, and recent inspection and repair status.
- EGLE has informally agreed to consent to use of all flow control structures for long term flow control. Request for formal consent is under review by them.

OMID Control Structure Upgrades Status:

Amt Invoiced: \$69,772 Engineering services to date; Total design and construction budget currently established as \$500,000 (including contingencies and admin/legal).

Schedule Status: Construction of cover mods substantially complete 8/14/20

- Hatch and Access improvements complete, CSM Contract closed-out.
- CS-5, CS-6, CS-7, and CS-8 mechanical repairs have been completed by HESCO and control structures are in stand-by mode, ready for service.
- HESCO has provided a study of control structures that evaluates long-term operability. This document is currently under review, and design for upgrades is in planning stages (ASI preparing a design scope and budget for consideration).

March 16, 2022 OMIDDD Board Meeting

OMID System 3-Year Spot Repairs and 6-Year Inspection Status:

Amt Invoiced: Total design and construction budget for 3-Year repairs currently is established as \$1,352,801 (including contingencies and admin/legal).

Schedule and Progress Status:

- Remaining 3-year spot repair work consists of step removal at one manhole in PCI-8, delayed due to access issues and timing of other work.
- The 6-Year inspection began July 8, 2021. After delays due to flow control, inspections have resumed and are nearing completion.
- Some damage noted to the CIPP Liner installed in 42" section of PCI-11A. Current plan is for Doetsch to remove the damaged section, grind the edges, and assess if anything more is necessary.

NIEA Repairs (Design/Construction)

Amt Invoiced: \$2,188,595 out of currently projected study/design budget of \$2,400,570; Total design and construction budget currently is \$44,168,770 (including contingencies and admin/legal). The current value of work completed is \$7,234,266.20 that represents 47% of the Contract sum., based on the current application for payment, and including stored materials.

Schedule Status: Contract 1: The Project Owner, the Engineer, and the Contractor have resolved current schedule delay issues related to Flow Control Management that resulted in an extension of Contract Time as well as a schedule replenishment of available "Operational Control" days. This time extension in addition to a more aggressive work schedule by the Contractor has resulted in a projected on-time completion for an adjusted Substantial Completion date of December 2, 2022.
Contract 2: 100% design work complete; expected to bid in early to mid 2022 pending permit resolution and coordination with GLWA projects that impact flow control requirements.

Progress for both contracts is summarized:

Contract 1 (PCI-4 Rehabilitation):

- Access shaft excavation and liner-plate TERS has advanced to the approximate springline of the PCI-4 Interceptor and placing of the concrete mud-mat is complete; structural headwalls to follow. Soil and groundwater conditions continue to be favorable.
- Geotechnical monitoring of construction activities indicates continuing stable conditions.
- Delivery of Channeline lining segments to the jobsite is now complete with 100% of the lining segments received.
- Manufacture of the QuakeWrap Carbon Fiber lining material continues at a facility in Hastings, MI and will be delivered to the jobsite on an "as-needed" basis.

March 16, 2022 OMIDDD Board Meeting



Solid Cast Polymer Panels at the Manufacturing Plant in Indiana



Quakewrap pipe section at the Manufacturing Plant in Hastings, MI

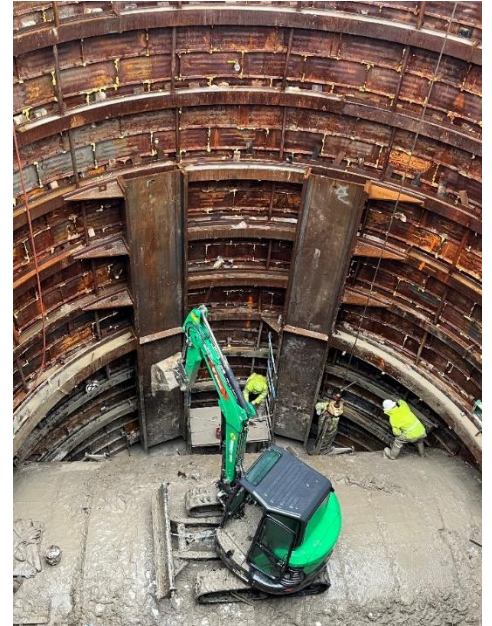

Status of excavation on February 2, 2022

Contract 2 (PCI -18/19 Rehabilitation)

- NI-EA OMID Contract No. 2 PCI-18 & 19 Rehabilitation 100% drawing set has been workshopped with OMIDDD and is ready for advertisement, pending final easements and GLWA agreement.
- Flow control necessary to complete Contract 2 work is expected to impact a downstream GLWA project (DB-226). Contract 2 is being structured such that potential interference between the two contracts can be mitigated.
- Current City of Detroit permitting issues are nearly resolved; certain follow-up issues remaining.
- Working with GLWA to develop cost sharing agreement; Draft agreement is currently being reviewed by GLWA Legal.

The **draft** line item schedule and budget are summarized:

March 16, 2022 OMIDDD Board Meeting

Work Item/ Milestone	Estimated Budget Expenditure (Engineering)	Estimated Budget Expenditure (Contractor)	Estimated Delivery Date
Lining Study Final Report	\$126,744		10/30/2019
90%, 100% Design Package			3/20/2020 and 4/28/2020 (Contract 1) 4/16/2021* and TBD* (Contract 2)
MDEQ Submittal (Part 41)			4/28/2020 (Contract 1) Pending* (Contract 2)
Issued for Bid			6/10/2020 (Contract 1) 4/2022* (Contract 2)
Bid Opening			9/30/2020 (Contract 1) April 2022* (Contract 2)
Contract Award and NTP			12/16/2020 and 1/04/2021 (Contract 1) TBD* (Contract 2)
Subtotal - Design	\$2,400,570		
Final Completion of Construction	\$3,500,000	\$35,000,000	07/23/2022* (Contract 1) 10/30/2023* (Contract 2)

*Estimated Date

NESPS Pump and Electrical Upgrades Project

Budget Status: \$1,280,139 billed out of current Design Budget of \$1,382,430; \$968,018 out of the current CCA Budget of \$2,443,262. Total construction budget currently established as \$45,001,517.63, including contingencies, through proposed C.O. #19). The total amount invoiced to date as of February 28, 2022 is \$22,741,992.48 (including the now completed and operational Control Structure 9 Bulkhead Gate facility, and adjusted for stored material inclusion in major work activities.), representing 50.5% of the combined project (Pump & Electrical Upgrades and CS-9 Gate Installation).

Schedule Status: Current reported delivery dates of the main sewage pumps and motors are delayed, due to manufacturing issues; however, resolution of these problems is in progress and pump and motor installation is moving forward. The Construction Manager is working to find options for schedule improvement and is now installing the major "Metal-Clad Substation gear" which represents a major milestone in the overall schedule.

The following Design Team and Construction Services Effort is active:

- A review of alternative energy saving methods and pump sequence remains ongoing, incorporating GLWA SCC comments.
- Construction Phase services (RFI's, Submittals) are ongoing, and the engineering team is reviewing and responding.
- Knife gate #1 has been removed and is currently undergoing rehabilitation.
- Interior electrical work is approaching completion with conduit and switchgear installation proceeding favorably. The Electrical building is now enclosed with the installation of overhead doors complete and temporary heat sources in operation.
- Discharge piping work is underway on Pumps # 1 and # 3, including pressure testing.

March 16, 2022 OMIDDD Board Meeting

- Chemical injection to seal groundwater infiltration at the existing discharge pipe wall penetrations is substantially complete, with final efforts on hold to observe the initial stages of grouting and determine if further measures may be required for final leak control.
- Small diameter conduit runs are being installed in the existing NESPS building with favorable progress, now approaching substantial completion for this activity.
- Pump 1 is to be shop tested later in March and shipped to the site.
- Knife Gate 1 is refurbished; shipping back to the site is pending.
- The **draft** line item schedule and budget are summarized:

Work Item/ Milestone		Design/CCA Budget	Const Budget	Estimated Delivery Date
2	Final Basis of Design			5/31/2019
7	MDEQ Submittal (Part 41 Permit)			4/8/2020 (initial pkg)
8	90% Design Submittal			6/30/20
9	Final Package Development			8/14/2020
	Subtotal	\$3,826,000	\$44,100,000	
10	Substantial Completion	\$2,500,000 (est.)	\$44,100,000 (est.)	3/24/2023
11	Final Completion			6/23/2023

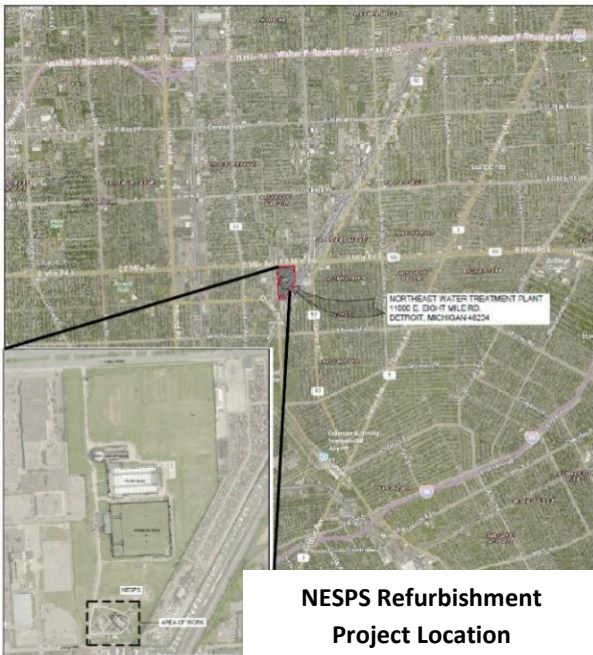

**NESPS Refurbishment
Project Location**

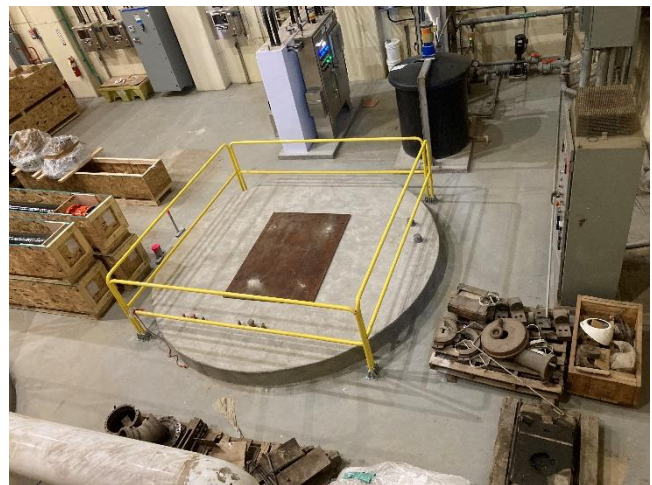

New Pump #1 Motor Foundation Pad

March 16, 2022 OMIDDD Board Meeting



Pump #3 Motor Foundation Pad



Pump #3 volute support foundations



Metal-clad switchgear in the new electrical building

CS-9 Gate Installation

Budget Status:

Total construction budget currently established as approximately \$3,314,218.01

Schedule Status:

Engineering/Design efforts complete; Work is now estimated at 99% complete based on current Progress Payment Applications, and the project is moving through final adjustments for equipment operation and flow control monitoring.

The following work is active:

- All major work is complete and the Hydrogate gate is in regular use for flow control management.

March 16, 2022 OMIDDD Board Meeting

- Site restoration is substantially complete and will be fully completed in Spring 2022.
- HOBAS representatives and Insurance Adjusters (Builder's Risk Insurance Claim) have been on-site to assess the damage from hatch covers that fell into the sewer. Doetsch Environmental is engaged to provide repair services. Repairs will also be necessary on the platform. This work will be performed in Spring 2022, with efforts underway to provide estimated cost documentation to the Insurance Carrier.

CS-9 Project location

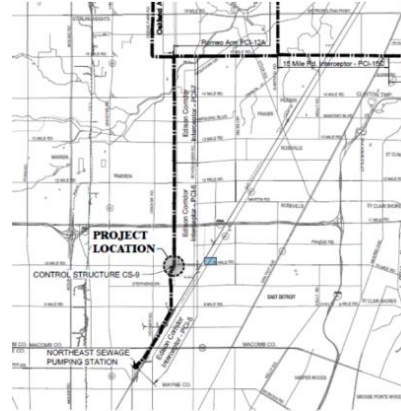

Summary of OMID Design and Construction Status:

Work In Construction Since 2009							
Seg. No	Contract No. (Description)	Contractor	Const. Comp?	As-Builts Final?	Balancing Change Order?	Contractor Closed Out?	Easements Settled?
1	Contract 1 (CS-9, 5, 3)	Ric-Man	Y	Y	Y	Y	Y
1	Contract 2 (CS-6, 7, 8)	Ric-Man	Y	Y	Y	Y	Y
2	Contract 3-2E (Gatehouse)	IWPC (Weiss)	Y	Y	Y*	Y	N/A
2	Contract 3 (Grouting PCI-5 thru 8)	IWPC	Y	Y	Y	Y	Y
3	Contract 4 (Lining PCI-5 thru 8)	Jay Dee Cont.	Y	Y	Y	Y	Y
4	Contract 5 (Lining PCI-9, 10A/B)	Lanzo	Y	Y	Y	Y	N
4	Contract 6 (Lining PCI-11A)	Lanzo	Y	Y	Y	Y	Y
N/A	Contract 7 (Lining 110' of NIEA)	IWPC	Y	Y	Y	Y	N/A
N/A	Odor/Corrosion Control System	CSM	Y	Y	Y	Y	N/A
N/A	Control Structure Modifications	CSM/Hesco/MCE	Y/Y/Y	Y/Y/N	Y/N/N	Y/N/N	N/A
N/A	OMID Maintenance Repairs	Doetsch	Y	N	N	N	N/A
N/A	CS-9 Gate Modifications	Walsh as CMR	Y	N	N	N	Y
N/A	NESPS Pump & Electrical Upgrade	ASI; Walsh as CMAR	N	N	N	N	Y
N/A	NIEA-OMIDDD Contract 1 (PCI-4)	Marra	N	N	N	N	N

* In process with Coating Issues Resolution and Change Order and Memo of Understanding approvals in review

March 16, 2022 OMIDDD Board Meeting

Work Currently in Design/Study/Engineering		
Description	Design Consultant	Status
System-wide Odor/Corrosion Study	Jacobs	Study Complete, modifications pending
NESPS & OMID Maintenance & Repairs	Metco	Engineering/Maintenance Ongoing
NIEA-OMIDDD Contract 2 (PCI-18/19)	NTH	Design Complete; pursuing cost sharing w/ GLWA
Emergency Pumping Plan	ASI/FKE	Design Complete; minor field work remains. System successfully tested; Draft Plan to be modified

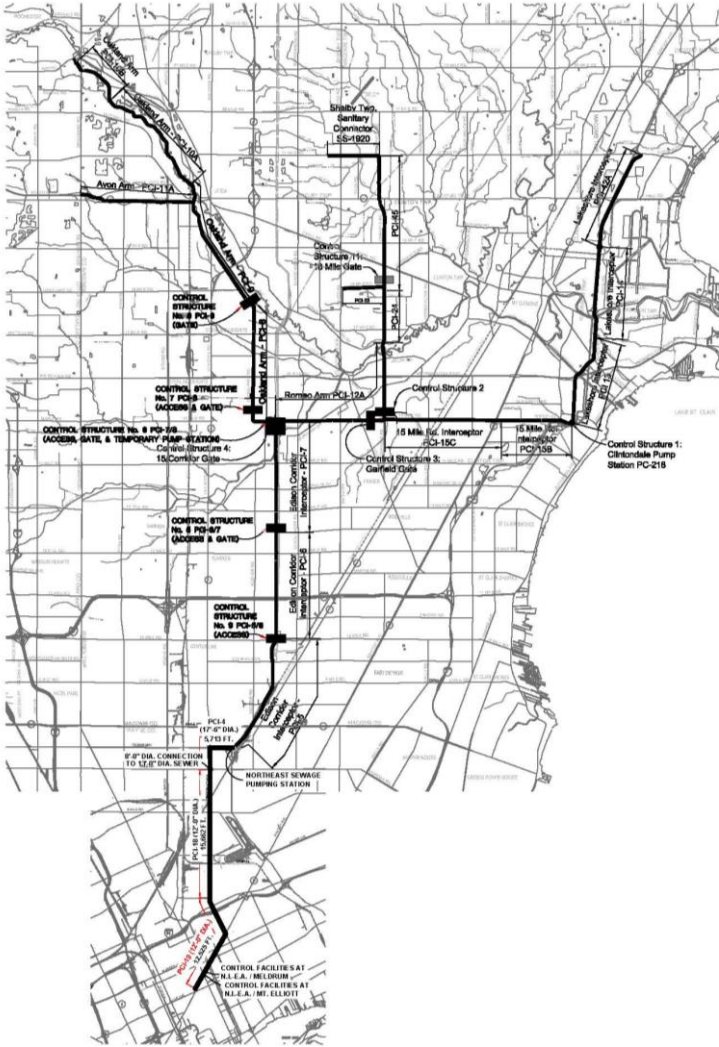

Overview of OMID System in Oakland, Macomb, and Wayne County

March 16, 2022 OMIDDD Board Meeting

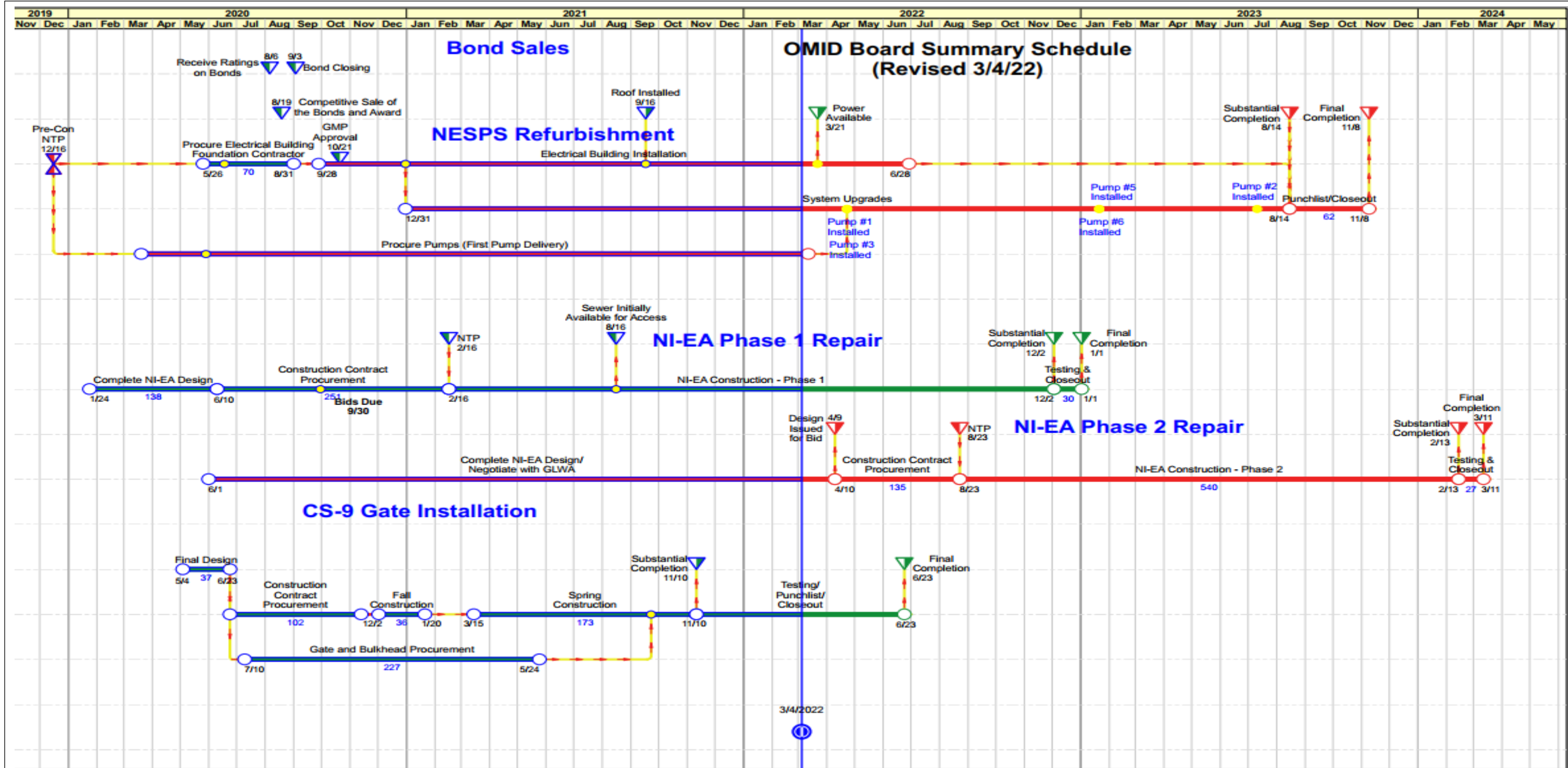

OMID Project Schedule Summary

March 16, 2022 OMIDDD Board Meeting

MID/OMID Construction Schedule

Project	Work Location	Owner	Lead Engineer	Contractor	2022												2023												MID/OMID Control Devices Required to Store Flow										Concurrent Work Notes														
					M	A	M	J	J	A	S	O	N	D	J	F	M	A	M	J	J	A	S	O	N	D	CS-2	CS-3	CS-5	CS-6	CS-6 PS	CS-7	CS-8	CS-9	CS-12	CPS																	
MID Grouting (Preliminary schedule has GI and LSI work beginning when	Lakeshore Interceptor (LSI)	MID	AEW	Doetsch	/	/	/	/	/	/	/	/	/	/	/	/	/	/	/	/	/	/	/	/	/	/	/	/	/	/	/	/	/	/	/	/	/	/	n/a	N	Work is Random - If other work requires CS-3 closure, then LSI work will be concurrent. CPS can not be used for storage. Schedule duration is TBD based on grout takes.		
MID Inspection	Routine Inspection of MID Manholes & Interceptors	MID	Fishbeck	Doetsch	/	/	/	/	/	/	/	/	/	/	/	/	/	/	/	/	/	/	/	/	/	/	/	/	/	/	/	/	/	/	/	/	/	n/a	.	Work may require brief flow control to inspect certain reaches. Work will be coordinated around active construction.				
Segment 6 Lining	15 Mile upstream of Garfield (15 Mile Interceptor)	MID	FKE	Ric-Man	/	/	/	/	/	/	/	/	/	/	/	/	/	/	/	/	/	/	/	/	/	/	/	/	/	/	/	/	/	/	/	/	/	n/a	Y	Flow control on pause but upcoming. May work concurrent with Segment 5 or NIEA rehabilitation. Schedule is preliminary.				
	15 Mile upstream of Garfield & between CS-2/CS-3 (Romeo Arm)	MID	FKE	Ric-Man	/	/	/	/	/	/	/	/	/	/	/	/	/	/	/	/	/	/	/	/	/	/	/	/	/	/	/	/	/	/	/	/	/	/	/	Y	Y	May work concurrent with Segment 5 or NIEA rehabilitation. Flow control conditions at the CS gates is similar with the exception of utilizing CS-2. Schedule is preliminary.		
Segment 5 Lining*	15 Mile between ITC Corridor & Eberlein	MID	FKE	OR	/	/	/	/	/	/	/	/	/	/	/	/	/	/	/	/	/	/	/	/	/	/	/	/	/	/	/	/	/	/	/	/	/	/	Y	H	If work is concurrent with NIEA rehabilitation; CS-9 is required. Flow control dates may change depending on sediment removal means and methods. Current projected finish is 2 months late.	
NIEA Rehabilitation (Downstream of NESPS)	PCI-4 Shaft & Lining	OMID	NTH	MARRA	/	/	/	/	/	/	/	/	/	/	/	/	/	/	/	/	/	/	/	/	/	/	/	/	/	/	/	/	/	/	/	/	/	/	H	If work is concurrent with Segments 5 & 6 Lining; CS-9 is required.	
	PCI-18/19 Spot Repairs, Lining, and Flow Controls	OMID	NTH	TBD	/	/	/	/	/	/	/	/	/	/	/	/	/	/	/	/	/	/	/	/	/	/	/	/	/	/	/	/	/	/	/	/	/	/	/	Shaft construction. MID/OMID flow control may be required depending on 7-Mile Relief Inter-Connection and PC-663 Gate status. Coordination with GLWA and downstream system when flow is diverted to 7 Mile Relief.
OMID CCTV Inspection	Throughout System	OMID	NTH	Doetsch	/	/	/	/	/	/	/	/	/	/	/	/	/	/	/	/	/	/	/	/	/	/	/	/	/	/	/	/	/	/	/	/	/	/	n/a	H	Present work is in upstream manholes so limited flow control necessary. Flow control will be required within certain reaches to facilitate.			
CS-9 Gate Installation & Hobas Repair	CS-9	OMID	NTH	Walsh	/	/	/	/	/	/	/	/	/	/	/	/	/	/	/	/	/	/	/	/	/	/	/	/	/	/	/	/	/	/	/	/	/	/	n/a	H	Hobas Repair Moved to Spring.			
NESPS Improvements	NESPS Pump Replacement	OMID	ASI	Walsh	/	/	/	/	/	/	/	/	/	/	/	/	/	/	/	/	/	/	/	/	/	/	/	/	/	/	/	/	/	/	/	/	/	/	H	Will require brief flow control for pump installation, gate installation, and electrical work.	
DB-226 DRI Repairs	GLWA - DRI	GLWA	FKE	Jay Dee	/	/	/	/	/	/	/	/	/	/	/	/	/	/	/	/	/	/	/	/	/	/	/	/	/	/	/	/	/	/	/	/	/	/	/	Can be effected by flows rerouted from the NIEA to the DRI.
PSPS / COSDS Work (PSPS Shutdown)	PSPS	WRC	n/a	n/a	/	/	/	/	/	/	/	/	/	/	/	/	/	/	/	/	/	/	/	/	/	/	/	/	/	/	/	/	/	/	/	/	/	/	/	Reduced diversion to PSPS this Fall to SMGD. Scheduled shut down of PSPS in September; no flow diversion to Pontiac WWTP (CRWRRF). Will significantly impact storage capabilities on the Oakland Arm CS gates.

- Y = Required to store
- N = Required to not store
- H = Helpful to extend work times. *if available when not required for concurrent work.*
- . = Irrelevant

Table updated on 3/1/2022. Estimates to be updated as necessary.

* Flow control will be required for sewer cleaning, currently estimated in 2022. Flow control requirements are TBD based on contractor means & methods, not reflected in "Control Devices Required to Store Flow" section.

* Flow control will be required for sewer lining (Schedule TBD). Flow control CS requirements are defined in the "Control Devices Required to Store Flow" section.

PSPS and ELPS operations can significantly impact storage times upstream of CS-6, 7 & 8 and subsequently downstream control structures. Coordination & alerting for ELPS, PSPS, WRC Meters 1222/1223 & 1000 required.

Estimated Project Window

Flow Control Required

Flow Control May Be Required

Note CS-6 is currently out of service

Agenda Item No. 9

Financial Reports – General Financial Report and
Status of State Revolving Fund Financing and
Other Financing

YTD Trial Balance
Fund: 84915 Oakland Macomb InterceptorSeg4
As of Fiscal Period: Month 5, 2022

Run By: WRC_REPORTING
Run: 03/05/2022 at 04:49 PM
Scope: 84915 Oakland Macomb InterceptorSeg4

ACCOUNT		Oakland Macomb InterceptorSeg4 100000001913	OMI NESPS GATEHOUSE SEG4 100000002232	NESPS Odor Corrosion Stdy Seg4 100000002708	YTD Balance
100100	Cash - Operating	0.00	0.00	0.00	0.00
104100	Accrued Interest on Investment	42,295.44	0.00	0.00	42,295.44
	Revenues	507.61	(7,602.55)	7,094.94	0.00
697551	Issuance of Bonds	561.05	(8,402.83)	7,841.78	0.00
	Expenditures	151.20	8,598.91	350.82	9,100.93
	Special Items- Uses	0.00	0.00	0.00	0.00
382100	FB Committed for Capital Proj	(43,515.30)	7,406.47	(15,287.54)	(51,396.37)
		(0.00)	0.00	(0.00)	0.00

SRF (SAW Loan) final draw request received January 2017.

	Cash as of 2/28/2022	\$	-
	Invoices/Reimbursements for Seg 4 on Current Agenda impacting Cash Balance		0.00
	Invoices/Reimbursements for NESPS NIEA-East Arm on Current Agenda impacting Cash Balance		0.00
	Invoices/Reimbursements for NESPS Odor Corrosion Study on Current Agenda impacting Cash Balance		0.00
	Total Net Cash Balance	\$	-

Water Resources Commissioner
PROJECT WORK IN PROGRESS
Oakland Macomb Interceptor Seg4
10000001913
 (as of February 28, 2022)

	Budget Amount	Month-to-Date Expenses	Life-to-Date Expenses	LTD Variance
ADM - Administration				
730926 - Indirect Costs		0.00	63,879.05	
730940 - Insurance		0.00	67,871.13	
731115 - Licenses and Permits		0.00	320,000.00	
731521 - Public Services		0.00	14,235.58	
732165 - Workshops and Meeting		0.00	29.66	
771638 - Drain Equip Labor		0.00	4,607.71	
771639 - Drain Equipment		0.00	269.47	
Administration TOTALS				
	390,165.00	0.00	470,892.60	(\$80,727.60)
ENG - Engineering				
731346 - Personal Mileage		0.00	18,616.01	
731521 - Public Services		0.00	40,605.00	
771638 - Drain Equip Labor		0.00	791,387.01	
771639 - Drain Equipment		0.00	84,680.70	
Engineering TOTALS				
	484,153.00	0.00	935,288.72	(\$451,135.72)
ENGCON - Engineering Consultant				
730639 - Engineering Services-Other		0.00	3,594,242.60	
731073 - Legal Services		0.00	108.00	
Engineering Consultant TOTALS				
	3,275,248.00	0.00	3,594,350.60	(\$319,102.60)
FAC - Facility Acquisition				
731472 - Project Construction and Impr		0.00	14,058,313.68	
731521 - Public Services		0.00	6,798.84	
750294 - Material and Supplies		0.00	228.00	
Facility Acquisition TOTALS				
	15,225,614.00	0.00	14,065,340.52	\$1,160,273.48
INS - Inspection				
730373 - Contracted Services		0.00	473.03	
731521 - Public Services		0.00	16,935.91	
Inspection TOTALS				
	17,408.00	0.00	17,408.94	(\$0.94)
LEGAL - Legal and Financial				
730639 - Engineering Services-Other		0.00	8,398.96	
730940 - Insurance		0.00	54,526.58	
731073 - Legal Services		0.00	124,753.11	
793938 - Discount on Bonds		0.00	6,964.10	
Legal and Financial TOTALS				
	191,321.00	0.00	194,642.75	(\$3,321.75)
ROW - Right of Way				
731563 - Recording Fees		0.00	50.67	
Right of Way TOTALS				
	0.00	0.00	50.67	(\$50.67)

Water Resources Commissioner

PROJECT WORK IN PROGRESS

Oakland Macomb InterceptorSeg4

10000001913

(as of February 28, 2022)

Budget Amount	Month-to-Date Expenses	Life-to-Date Expenses	LTD Variance
Project 10000001913 - Oakland Macomb InterceptorSeg4			
Total Project Expenses			
Budget Amount	Month-to-Date Expenses	Life-to-Date Expenses	LTD Variance
\$19,583,909.00	\$0.00	\$19,277,974.80	\$305,934.20
Total Project Revenue			
Account	Month-to-Date Revenue	Life-to-Date Revenue	
605572-Special Assessments	\$0.00	\$8,332,360.91	
615572-State Capital Grants	\$0.00	\$1,105,350.77	
655077-Accrued Interest Adjustments	\$0.00	\$42,295.44	
655385-Income from Investments	\$0.00	\$651,137.07	
697551-Issuance of Bonds	\$0.00	\$699,126.05	
697753-State Revolving Fund Loans	\$0.00	\$8,490,000.00	
TOTAL REVENUE	\$0.00	\$19,320,270.24	
REVENUE OVER/(UNDER) EXPENSES		\$42,295.44	

Water Resources Commissioner
PROJECT WORK IN PROGRESS
OMI NESPS GATEHOUSE SEG4
10000002232
 (as of February 28, 2022)

	Budget Amount	Month-to-Date Expenses	Life-to-Date Expenses	LTD Variance
ADM - Administration				
730926 - Indirect Costs		0.00	1,217.23	
771638 - Drain Equip Labor		0.00	53.43	
Administration TOTALS	9,472.00	0.00	1,270.66	\$8,201.34
CONT - Contingency				
Contingency TOTALS	93,209.00	0.00	0.00	\$93,209.00
ENG - Engineering				
771638 - Drain Equip Labor		0.00	13,790.23	
771639 - Drain Equipment		0.00	598.96	
Engineering TOTALS	59,699.00	0.00	14,389.19	\$45,309.81
ENGCON - Engineering Consultant				
730639 - Engineering Services-Other		0.00	1,290,710.41	
Engineering Consultant TOTALS	496,981.00	0.00	1,290,710.41	(\$793,729.41)
FAC - Facility Acquisition				
731472 - Project Construction and Impr		0.00	3,456,264.64	
Facility Acquisition TOTALS	3,748,637.00	0.00	3,456,264.64	\$292,372.36
INS - Inspection				
771638 - Drain Equip Labor		0.00	1,277.93	
771639 - Drain Equipment		0.00	59.93	
Inspection TOTALS	5,000.00	0.00	1,337.86	\$3,662.14
LEGAL - Legal and Financial				
731073 - Legal Services		0.00	1,456.00	
Legal and Financial TOTALS	6,000.00	0.00	1,456.00	\$4,544.00

Project 10000002232 - OMI NESPS GATEHOUSE SEG4			
Total Project Expenses			
Budget Amount	Month-to-Date Expenses	Life-to-Date Expenses	LTD Variance
\$4,418,998.00	\$0.00	\$4,765,428.76	(\$346,430.76)
Total Project Revenue			
Account	Month-to-Date Revenue	Life-to-Date Revenue	
605572-Special Assessments	\$0.00	\$2,442,316.94	
697551-Issuance of Bonds	\$0.00	\$2,323,111.82	
TOTAL REVENUE	\$0.00	\$4,765,428.76	
REVENUE OVER/(UNDER) EXPENSES			(\$0.00)

Water Resources Commissioner

PROJECT WORK IN PROGRESS

NESPS Odor Corrosion Study Seg4

10000002708

(as of February 28, 2022)

	Budget Amount	Month-to-Date Expenses	Life-to-Date Expenses	LTD Variance
ADM - Administration				
730926 - Indirect Costs		0.00	25,041.48	
730940 - Insurance		0.00	184,130.93	
Administration TOTALS	188,148.00	0.00	209,172.41	(\$21,024.41)
CONT - Contingency				
Contingency TOTALS	637,000.00	0.00	0.00	\$637,000.00
ENG - Engineering				
771638 - Drain Equip Labor		0.00	123,668.71	
771639 - Drain Equipment		0.00	4,628.70	
Engineering TOTALS	206,253.00	0.00	128,297.41	\$77,955.59
ENGCON - Engineering Consultant				
730373 - Contracted Services		0.00	1,317,523.99	
Engineering Consultant TOTALS	1,073,000.00	0.00	1,317,523.99	(\$244,523.99)
FAC - Facility Acquisition				
730352 - Construction		0.00	779,225.00	
731472 - Project Construction and Impr		0.00	4,268,094.51	
Facility Acquisition TOTALS	4,600,000.00	0.00	5,047,319.51	(\$447,319.51)
INS - Inspection				
771638 - Drain Equip Labor		0.00	212,352.47	
771639 - Drain Equipment		0.00	32,443.08	
Inspection TOTALS	190,343.00	0.00	244,795.55	(\$54,452.55)
LEGAL - Legal and Financial				
731073 - Legal Services		0.00	1,744.00	
Legal and Financial TOTALS	15,000.00	0.00	1,744.00	\$13,256.00
ROW - Right of Way				
Right of Way TOTALS	46,000.00	0.00	0.00	\$46,000.00
STD - Standard Operation				
730926 - Indirect Costs		0.00	3,729.80	
731906 - Testing Services		0.00	31,382.05	
771638 - Drain Equip Labor		0.00	4,613.57	
771639 - Drain Equipment		0.00	2,460.66	
Standard Operation TOTALS	38,010.00	0.00	42,186.08	(\$4,176.08)
SUR - Survey Crew				
Survey Crew TOTALS	10,246.00	0.00	0.00	\$10,246.00

Water Resources Commissioner

PROJECT WORK IN PROGRESS

NESPS Odor Corrosion Stdy Seg4

10000002708

(as of February 28, 2022)

Budget Amount	Month-to-Date Expenses	Life-to-Date Expenses	LTD Variance
Project 10000002708 - NESPS Odor Corrosion Stdy Seg4			
Total Project Expenses			
Budget Amount	Month-to-Date Expenses	Life-to-Date Expenses	LTD Variance
\$7,004,000.00	\$0.00	\$6,991,038.95	\$12,961.05
Total Project Revenue			
Account	Month-to-Date Revenue	Life-to-Date Revenue	
605572-Special Assessments	\$0.00	\$3,273,276.82	
697551-Issuance of Bonds	\$0.00	\$3,717,762.13	
TOTAL REVENUE	\$0.00	\$6,991,038.95	
REVENUE OVER/(UNDER) EXPENSES		(\$0.00)	

YTD Trial Balance

Fund: 84917 Oakland Macomb InterceptorSeg5

As of Fiscal Period: Month 5, 2022

Run By: WRC_REPORTING

Run: 03/05/2022 at 04:50 PM

Scope: 84917 Oakland Macomb InterceptorSeg5

ACCOUNT		OMID Segment 5 100000003252	OMID NIEA CONSTRUCTION 100000003308	NESPS MECH-ELEC CONSTRUCTION 100000003309	YTD Balance
100100	Cash - Operating	1,421,158.24	13,611,927.06	33,342,702.47	48,375,787.77
104100	Accrued Interest on Investment	(164,104.22)	0.00	0.00	(164,104.22)
151000	Restricted Cash	0.00	3,381,615.00	0.00	3,381,615.00
201210	Vouchers Payable AP Cont	0.00	(5,265.60)	(156,629.18)	(161,894.78)
222300	Unearned Revenues	(208,809.66)	(4,224,457.35)	(8,046,142.99)	(12,479,410.00)
	Revenues	435,973.32	0.00	0.00	33,761.53
	Expenditures	0.00	2,352,504.27	3,808,954.45	6,161,458.72
	Special Items- Uses	0.00	0.00	0.00	0.00
381315	FB Restricted Debt	(47,288,433.00)	0.00	0.00	(47,288,433.00)
382100	FB Committed for Capital Proj	45,804,215.32	(15,116,323.38)	(28,948,884.75)	2,141,218.98
		0.00	0.00	(0.00)	(0.00)

Cash as of 02/28/2022 \$ 48,375,787.77

Invoices/Reimbursements for NIEA Construction on Current Agenda impacting Cash Balance (110,608.74)

Invoices/Reimbursements for NESPS Mech / Electrical Construction on Current Agenda impacting Cash Balance (74,638.73)

Total Net Cash Balance \$ 48,190,540.30

Water Resources Commissioner
PROJECT WORK IN PROGRESS
OMID NI-EA CONSTRUCTION
10000003308
 (as of February 28, 2022)

	Budget Amount	Month-to-Date Expenses	Life-to-Date Expenses	LTD Variance
ADM - Administration				
Administration TOTALS	584,000.00	0.00	0.00	\$584,000.00
CONT - Contingency				
Contingency TOTALS	2,581,000.00	0.00	0.00	\$2,581,000.00
ENG - Engineering				
771638 - Drain Equip Labor		3,894.57	84,056.30	
771639 - Drain Equipment		158.01	3,315.51	
Engineering TOTALS	478,000.00	4,052.58	87,371.81	\$390,628.19
ENGCON - Engineering Consultant				
730639 - Engineering Services-Other		0.00	502,022.23	
731444 - Prof Svc-Consultant		0.00	954,190.99	
731472 - Project Construction and Impr		0.00	539,637.75	
Engineering Consultant TOTALS	4,913,000.00	0.00	1,995,850.97	\$2,917,149.03
FAC - Facility Acquisition				
730352 - Construction		0.00	2,947,868.47	
731472 - Project Construction and Impr		0.00	6,189,272.79	
Facility Acquisition TOTALS	17,983,600.00	0.00	9,137,141.26	\$8,846,458.74
INS - Inspection				
Inspection TOTALS	260,000.00	0.00	0.00	\$260,000.00
LEGAL - Legal and Financial				
730940 - Insurance		0.00	41,250.00	
731073 - Legal Services		4,770.50	43,531.50	
Legal and Financial TOTALS	1,259,000.00	4,770.50	84,781.50	\$1,174,218.50
ROW - Right of Way				
730373 - Contracted Services		0.00	3,625.00	
731038 - Land and Easement		0.00	-300.00	
731073 - Legal Services		495.10	17,746.90	
731661 - RW Negotiation and Expense		0.00	5,000.00	
771638 - Drain Equip Labor		0.00	44,895.09	
771639 - Drain Equipment		0.00	1,791.20	
Right of Way TOTALS	265,000.00	495.10	72,758.19	\$192,241.81
STD - Standard Operation				
730639 - Engineering Services-Other		0.00	29,419.81	
Standard Operation TOTALS	40,000.00	0.00	29,419.81	\$10,580.19
SUR - Survey Crew				

Water Resources Commissioner

PROJECT WORK IN PROGRESS

OMID NI-EA CONSTRUCTION

10000003308

(as of February 28, 2022)

Budget Amount	Month-to-Date Expenses	Life-to-Date Expenses	LTD Variance
Survey Crew TOTALS			
32,000.00	0.00	0.00	\$32,000.00

Project 10000003308 - OMID NI-EA CONSTRUCTION			
Total Project Expenses			
Budget Amount	Month-to-Date Expenses	Life-to-Date Expenses	LTD Variance
\$28,395,600.00	\$9,318.18	\$11,407,323.54	\$16,988,276.46
Total Project Revenue			
Account	Month-to-Date Revenue	Life-to-Date Revenue	
605572-Special Assessments	\$0.00	\$2,206,043.00	
697551-Issuance of Bonds	\$0.00	\$21,965,099.65	
TOTAL REVENUE	\$0.00	\$24,171,142.65	
REVENUE OVER/(UNDER) EXPENSES		\$12,763,819.11	

Water Resources Commissioner
PROJECT WORK IN PROGRESS
NESPS MECH-ELEC CONSTRUCTION
10000003309
 (as of February 28, 2022)

	Budget Amount	Month-to-Date Expenses	Life-to-Date Expenses	LTD Variance
ADM - Administration				
730940 - Insurance		0.00	44,200.00	
Administration TOTALS				
	620,000.00	0.00	44,200.00	\$575,800.00
CONT - Contingency				
Contingency TOTALS				
	4,917,000.00	0.00	0.00	\$4,917,000.00
ENG - Engineering				
731346 - Personal Mileage		0.00	352.80	
771638 - Drain Equip Labor		4,581.74	127,579.22	
771639 - Drain Equipment		141.80	4,955.01	
Engineering TOTALS				
	446,000.00	4,723.54	132,887.03	\$313,112.97
ENGCON - Engineering Consultant				
730639 - Engineering Services-Other		156,629.18	1,314,218.36	
731444 - Prof Svc-Consultant		0.00	130,587.68	
731458 - Professional Services		0.00	94,603.44	
Engineering Consultant TOTALS				
	3,987,000.00	156,629.18	1,539,409.48	\$2,447,590.52
FAC - Facility Acquisition				
731472 - Project Construction and Impr		0.00	18,590,301.58	
Facility Acquisition TOTALS				
	40,857,000.00	0.00	18,590,301.58	\$22,266,698.42
INS - Inspection				
731458 - Professional Services		0.00	532.00	
771638 - Drain Equip Labor		13,529.75	235,175.72	
771639 - Drain Equipment		1,567.98	27,850.90	
Inspection TOTALS				
	285,000.00	15,097.73	263,558.62	\$21,441.38
LEGAL - Legal and Financial				
730940 - Insurance		0.00	179,800.00	
Legal and Financial TOTALS				
	2,417,000.00	0.00	179,800.00	\$2,237,200.00
ROW - Right of Way				
Right of Way TOTALS				
	393,000.00	0.00	0.00	\$393,000.00
STD - Standard Operation				
730940 - Insurance		0.00	149,770.00	
Standard Operation TOTALS				
	130,000.00	0.00	149,770.00	(\$19,770.00)
SUR - Survey Crew				
Survey Crew TOTALS				
	34,000.00	0.00	0.00	\$34,000.00

Water Resources Commissioner

PROJECT WORK IN PROGRESS

NESPS MECH-ELEC CONSTRUCTION

10000003309

(as of February 28, 2022)

Budget Amount	Month-to-Date Expenses	Life-to-Date Expenses	LTD Variance
Project 10000003309 - NESPS MECH-ELEC CONSTRUCTION			
Total Project Expenses			
Budget Amount	Month-to-Date Expenses	Life-to-Date Expenses	LTD Variance
\$54,086,000.00	\$176,450.45	\$20,899,926.71	\$33,186,073.29
Total Project Revenue			
Account	Month-to-Date Revenue	Life-to-Date Revenue	
605572-Special Assessments	\$0.00	\$4,202,235.00	
697551-Issuance of Bonds	\$0.00	\$41,837,622.01	
TOTAL REVENUE	\$0.00	\$46,039,857.01	
REVENUE OVER/(UNDER) EXPENSES		\$25,139,930.30	

Water Resources Commissioner

PROJECT WORK IN PROGRESS

OMID Segment 5

10000003252

(as of February 28, 2022)

Budget Amount	Month-to-Date Expenses	Life-to-Date Expenses	LTD Variance
---------------	------------------------	-----------------------	--------------

ADM - Administration

730177 - Bond Issuing Cost	0.00	242,201.57
----------------------------	------	------------

Administration TOTALS	0.00	0.00	242,201.57	(\$242,201.57)
------------------------------	------	------	------------	----------------

LEGAL - Legal and Financial

730177 - Bond Issuing Cost	0.00	514,935.00
----------------------------	------	------------

Legal and Financial TOTALS	0.00	0.00	514,935.00	(\$514,935.00)
-----------------------------------	------	------	------------	----------------

Project 10000003252 - OMID Segment 5

Total Project Expenses

Budget Amount	Month-to-Date Expenses	Life-to-Date Expenses	LTD Variance
\$0.00	\$0.00	\$757,136.57	(\$757,136.57)

Total Project Revenue

Account	Month-to-Date Revenue	Life-to-Date Revenue	
605572-Special Assessments	\$0.00	\$108,835.74	
655077-Accrued Interest Adjustments	\$14,901.63	(\$164,104.22)	
655385-Income from Investments	\$8,328.67	\$775,646.32	
697219-Premiums on Bonds Sold	\$0.00	\$7,672,724.75	
697551-Issuance of Bonds	\$0.00	(\$6,587,721.66)	
TOTAL REVENUE	\$23,230.30	\$1,805,380.93	
REVENUE OVER/(UNDER) EXPENSES		\$1,048,244.36	

Run by: 32808
 Run: 03/05/2022 at 06:06 PM
 Scope: 82912 Oakland Macomb InterceptorCh21
 Fiscal Period: Month 5 2022

Oakland County - Water Resources Commissioner's Office
Statement of Net Assets
As of Date: Feb 28, 2022
Fund: 82912 Oakland Macomb InterceptorCh21

	MAJOR MAINTENANCE RESERVE	EMERGENCY MAINTENANCE RESERVE	CAPITAL IMPROVEMENT RESERVE	UNDESIGNATED RETAINED EARNINGS	TOTAL
Total Net Assets Beginning	2,848,992.42	1,500,000.00	2,413,875.04	7,639,026.97	14,401,894.43
Increases	479,166.65	208,333.35	339,959.30	30,408,788.85	31,436,248.15
Decreases	18,917.32	1,920,136.89	3,530.11	29,065,699.28	31,008,283.60
Adjustments	0.00	3,211,803.54	0.00	(3,211,803.54)	0.00
Total Net Assets Ending	<u>3,309,241.75</u>	<u>3,000,000.00</u>	<u>2,750,304.23</u>	<u>5,770,313.00</u>	<u>14,829,858.98</u>
Net Assets Invested in Capital as of 02/28/2022				0.00	0.00
Current year adjustments				0.00	0.00
ESTIMATED Undesignated Retained Earnings				<u>5,770,313.00</u>	<u>14,829,858.98</u>

OAKLAND MACOMB INTERCEPTOR DRAINAGE BOARD - APPROVAL OF INVOICES/REIMBURSEMENTS

OMI DD Meeting Date 3/16/2022

Payable To	Invoice #	84915	84915	84915	84917	84917	82912	Total
		1-1913	1-2232	1-2708	1-3308	1-3309		
		<u>Segment 4</u>	<u>Segment 4 - NESPS Gate House</u>	<u>Segment 4 - NESPS Odor Corrosion Study</u>	<u>Segment 5 NIEA Construction</u>	<u>Segment 5 NESPS Mech / Electric Construction</u>	<u>Operations & Maintenance</u>	
Oakland County *	WRC Labor/Fringes/Non-direct Labor				3,894.57	18,111.49		\$22,006.06
Oakland County *	WRC Equipment				158.01	1,709.78		\$1,867.79
Applied Science, Inc	Invoice # 37 (ASI Inv. #8057) Services 01/30/22 to 02/26/22					72,559.95		\$72,559.95
CH2M - LG Design	Invoice # 705773CH036 Services 1/1/22 - 1/28/22						4,409.10	\$4,409.10
Clark Hill PLC	Invoice # 1174160 Matter 404547 Services Through 01/31/2022				5,913.00			\$5,913.00
Clark Hill PLC	Invoice # 1174161 Matter 424741 Services Through 01/31/2022						4,698.00	\$4,698.00
Comerica - P Card reimbursement	Panara Bread OMIDD Meeting Catering 2/16/2022						70.82	\$70.82
CSM Mechanical, LLC	Invoice # 21OMIDD002 Bypass 3" Bio Trickle Drain Invoice Date 08/26/21						3,480.00	\$3,480.00
CSM Mechanical, LLC	Invoice # 21OMIDD007 Pump 5 Valve Replace Invoice Date 12/07/21						562.50	\$562.50
CSM Mechanical, LLC	Invoice # 21OMIDD009 Brackets Wet Well Hatches Invoice Date 10/04/21						4,961.00	\$4,961.00
CSM Mechanical, LLC	Invoice # 21OMIDD011 VFD Repair Invoice Date 06/30/21						3,099.26	\$3,099.26
CSM Mechanical, LLC	Invoice # 21OMIDD013 Pump 6 Preassure Guage Invoice Date 12/07/21						360.00	\$360.00
CSM Mechanical, LLC	Invoice # 22OMIDD-003 Secure Sump House to Wall Invoice Date 02/10/22						645.00	\$645.00
HESCO	Invoice # 2213446 Preventative Maintenance 02/11/2022						6,724.75	\$6,724.75
HESCO	Invoice # 2213447 OMIDD Wet Well Sensor 02/11/2022						1,202.50	\$1,202.50
HESCO	Invoice # 2213456 Preventative Maintenance 02/17/2022						4,579.75	\$4,579.75
HESCO	Invoice # 20212685 Wet Well Level Sensor / Gate Service 02/15/2021						4,543.75	\$4,543.75
METCO	Invoice # 1811-37 Through 01/30/22						84,877.13	\$84,877.13
METCO	Invoice # 1811-38 Through 02/27/22						70,448.33	\$70,448.33
Motor City Electric Technologies	Invoice # 94246 NESP SCADA Cut Over Service Date 01/04/22						189.00	\$189.00
Motor City Electric Technologies	Invoice # 94247 NESP SCADA Cut Over Service Date 01/05/22						180.00	\$180.00
Motor City Electric Technologies	Invoice # 94264 NESP SCADA Cut Over Service Date 02/07/22						725.64	\$725.64
Motor City Electric Technologies	Invoice # 94265 NESP SCADA Cut Over Service Date 02/01/22						54.00	\$54.00
Motor City Electric Technologies	Invoice # 94266 NESP SCADA Cut Over Service Date 02/02/22						63.00	\$63.00
Motor City Electric Technologies	Invoice # 94267 NESP SCADA Cut Over Service Date 02/03/22						315.00	\$315.00
Motor City Electric Technologies	Invoice # 94319 NESP SCADA Cut Over Service Date 03/01/22						716.64	\$716.64
Motor City Electric Technologies	Invoice # 94320 NESP SCADA Cut Over Service Date 02/24/22						135.00	\$135.00
NTH Consultants	Inv # 02 For NESPS Supplementary Support Service Through 02/18/2022						9,901.20	\$9,901.20
NTH Consultants	Inv # 07 For 2021 OMIDD System Inspection Service Through 02/18/2022						7,323.35	\$7,323.35
NTH Consultants	Inv # 15 NI-EA Construction Engineering Service (D-425) Through 02/18/2022				88,099.04			\$88,099.04
NTH Consultants	Inv # 15 NI-EA Construction Engineering Service (D-421) Through 02/18/2022					2,078.78		\$2,078.78
NTH Consultants	Inv # 33 - OMIDD NI-EA Rehab Services Through 02/18/2022				16,596.70			\$16,596.70
NTH Consultants	Inv # 62 - OMIDD NESPS Discharge Chamber Service Through 02/18/2022						6,455.98	\$6,455.98
PMA Consultants	Invoice # 03559.01 - 20 Professional Services Through 01/31/22					15,711.73		\$8,757.36
	Total Invoices/Reimbursements for Approval	\$0.00	\$0.00	\$0.00	\$114,661.32	\$94,460.00	\$220,720.70	\$429,842.02
	* Less WRC Charges already paid from OMI Fund	0.00	0.00	0.00	(4,052.58)	(19,821.27)	0.00	(23,873.85)
	Total Invoices/Reimbursements that will impact Cash Balance listed on Current Trial Balance submitted to OMI Drain Board	\$0.00	\$0.00	\$0.00	\$110,608.74	\$74,638.73	\$220,720.70	\$405,968.17

Agenda Item No. 10

Invoices

OMI Segment 5 NESP Mech - Elect Construction Project - WRC Labor/Fringes/Non-Direct Labor Factor for Trans Dates - 1/29/2021 - 2/25/2022									
WOID	Date Entered	Date Worked	Name/Description	Hours/Units	Cost	Cost Category	Assign Equipment	Project	Activity
984656	02/07/22	01/18/22	BROWN, JOEL	1.50	188.18	REGULAR	WRCCON	100000003309	ENG
984656	02/07/22	01/19/22	BROWN, JOEL	2.00	250.90	REGULAR	WRCCON	100000003309	ENG
984656	02/07/22	01/20/22	BROWN, JOEL	4.00	501.80	REGULAR	WRCCON	100000003309	ENG
984656	02/07/22	01/24/22	BROWN, JOEL	2.00	250.90	REGULAR	WRCCON	100000003309	ENG
984656	02/07/22	01/25/22	BROWN, JOEL	2.00	250.90	REGULAR	WRCCON	100000003309	ENG
984656	02/07/22	01/26/22	BROWN, JOEL	2.50	313.63	REGULAR	WRCCON	100000003309	ENG
984656	02/07/22	01/27/22	BROWN, JOEL	4.00	501.80	REGULAR	WRCCON	100000003309	ENG
984656	02/07/22	01/28/22	BROWN, JOEL	1.00	125.45	REGULAR	WRCCON	100000003309	ENG
984656	02/16/22	01/31/22	BROWN, JOEL	1.50	188.18	REGULAR	WRCCON	100000003309	ENG
984656	02/16/22	02/01/22	BROWN, JOEL	2.00	250.90	REGULAR	WRCCON	100000003309	ENG
984656	02/16/22	02/02/22	BROWN, JOEL	1.00	125.45	REGULAR	WRCCON	100000003309	ENG
984656	02/16/22	02/03/22	BROWN, JOEL	1.50	188.18	REGULAR	WRCCON	100000003309	ENG
984656	02/16/22	02/07/22	BROWN, JOEL	2.00	250.90	REGULAR	WRCCON	100000003309	ENG
984656	02/16/22	02/10/22	BROWN, JOEL	3.00	376.35	REGULAR	WRCCON	100000003309	ENG
			BROWN, JOEL Total		3,763.52				
1050210	02/01/22	01/31/22	CARLEY, JOSEPH	1.00	81.65	REGULAR	WRCCDM	100000003309	INS
1050210	02/08/22	02/07/22	CARLEY, JOSEPH	1.00	81.65	REGULAR	WRCCDM	100000003309	INS
1050210	02/18/22	02/18/22	CARLEY, JOSEPH	2.00	163.30	REGULAR	WRCCDM	100000003309	INS
1050210	02/22/22	02/22/22	CARLEY, JOSEPH	1.00	81.65	REGULAR	WRCCDM	100000003309	INS
			CARLEY, JOSEPH Total		408.25				
984656	02/15/22	02/01/22	LOCKHART, SIDNEY	2.00	272.74	REGULAR	WRCADM	100000003309	ENG
984656	02/15/22	02/04/22	LOCKHART, SIDNEY	2.00	272.74	REGULAR	WRCADM	100000003309	ENG
984656	02/15/22	02/08/22	LOCKHART, SIDNEY	2.00	272.74	REGULAR	WRCADM	100000003309	ENG
			LOCKHART, SIDNEY Total		818.22				
1050210	02/01/22	01/31/22	ROBERTS, PATRICK	8.00	564.24	REGULAR	WRCCDM	100000003309	INS
1050210	02/01/22	01/31/22	ROBERTS, PATRICK	2.00	164.00	OVERTIME	WRCCDM	100000003309	INS
1050210	02/01/22	02/01/22	ROBERTS, PATRICK	8.00	564.24	REGULAR	WRCCDM	100000003309	INS
1050210	02/01/22	02/01/22	ROBERTS, PATRICK	1.00	82.00	OVERTIME	WRCCDM	100000003309	INS
1050210	02/02/22	02/02/22	ROBERTS, PATRICK	8.00	564.24	REGULAR	WRCCDM	100000003309	INS
1050210	02/02/22	02/02/22	ROBERTS, PATRICK	1.00	82.00	OVERTIME	WRCCDM	100000003309	INS
1050210	02/03/22	02/03/22	ROBERTS, PATRICK	8.00	564.24	REGULAR	WRCCDM	100000003309	INS
1050210	02/03/22	02/03/22	ROBERTS, PATRICK	1.00	82.00	OVERTIME	WRCCDM	100000003309	INS
1050210	02/04/22	02/04/22	ROBERTS, PATRICK	8.00	564.24	REGULAR	WRCCDM	100000003309	INS
1050210	02/04/22	02/04/22	ROBERTS, PATRICK	1.00	82.00	OVERTIME	WRCCDM	100000003309	INS
1050210	02/07/22	02/07/22	ROBERTS, PATRICK	8.00	564.24	REGULAR	WRCCDM	100000003309	INS
1050210	02/07/22	02/07/22	ROBERTS, PATRICK	2.00	164.00	OVERTIME	WRCCDM	100000003309	INS
1050210	02/08/22	02/08/22	ROBERTS, PATRICK	8.00	564.24	REGULAR	WRCCDM	100000003309	INS
1050210	02/08/22	02/08/22	ROBERTS, PATRICK	1.00	82.00	OVERTIME	WRCCDM	100000003309	INS
1050210	02/09/22	02/09/22	ROBERTS, PATRICK	8.00	564.24	REGULAR	WRCCDM	100000003309	INS
1050210	02/09/22	02/09/22	ROBERTS, PATRICK	1.00	82.00	OVERTIME	WRCCDM	100000003309	INS
1050210	02/10/22	02/10/22	ROBERTS, PATRICK	8.00	564.24	REGULAR	WRCCDM	100000003309	INS
1050210	02/10/22	02/10/22	ROBERTS, PATRICK	2.00	164.00	OVERTIME	WRCCDM	100000003309	INS
1050210	02/11/22	02/11/22	ROBERTS, PATRICK	8.00	564.24	REGULAR	WRCCDM	100000003309	INS
1050210	02/11/22	02/11/22	ROBERTS, PATRICK	1.00	82.00	OVERTIME	WRCCDM	100000003309	INS
1050210	02/14/22	02/14/22	ROBERTS, PATRICK	8.00	564.24	REGULAR	WRCCDM	100000003309	INS
1050210	02/14/22	02/14/22	ROBERTS, PATRICK	1.00	82.00	OVERTIME	WRCCDM	100000003309	INS
1050210	02/15/22	02/15/22	ROBERTS, PATRICK	8.00	564.24	REGULAR	WRCCDM	100000003309	INS
1050210	02/15/22	02/15/22	ROBERTS, PATRICK	2.00	164.00	OVERTIME	WRCCDM	100000003309	INS
1050210	02/16/22	02/16/22	ROBERTS, PATRICK	8.00	564.24	REGULAR	WRCCDM	100000003309	INS
1050210	02/16/22	02/16/22	ROBERTS, PATRICK	1.00	82.00	OVERTIME	WRCCDM	100000003309	INS
1050210	02/17/22	02/17/22	ROBERTS, PATRICK	6.00	423.18	REGULAR	WRCCDM	100000003309	INS
1050210	02/18/22	02/18/22	ROBERTS, PATRICK	8.00	564.24	REGULAR	WRCCDM	100000003309	INS
1050210	02/18/22	02/18/22	ROBERTS, PATRICK	1.00	82.00	OVERTIME	WRCCDM	100000003309	INS
1050210	02/21/22	02/21/22	ROBERTS, PATRICK	9.00	738.00	HOLIDAY	WRCCDM	100000003309	INS
1050210	02/22/22	02/22/22	ROBERTS, PATRICK	8.00	564.24	REGULAR	WRCCDM	100000003309	INS
1050210	02/22/22	02/22/22	ROBERTS, PATRICK	1.00	82.00	OVERTIME	WRCCDM	100000003309	INS
1050210	02/23/22	02/23/22	ROBERTS, PATRICK	8.00	564.24	REGULAR	WRCCDM	100000003309	INS
1050210	02/23/22	02/23/22	ROBERTS, PATRICK	1.00	82.00	OVERTIME	WRCCDM	100000003309	INS
1050210	02/24/22	02/24/22	ROBERTS, PATRICK	8.00	564.24	REGULAR	WRCCDM	100000003309	INS
1050210	02/24/22	02/24/22	ROBERTS, PATRICK	1.00	82.00	OVERTIME	WRCCDM	100000003309	INS
1050210	02/25/22	02/25/22	ROBERTS, PATRICK	8.00	564.24	REGULAR	WRCCDM	100000003309	INS
1050210	02/25/22	02/25/22	ROBERTS, PATRICK	1.00	82.00	OVERTIME	WRCCDM	100000003309	INS
			ROBERTS, PATRICK Total		13,121.50				
			Grand Total		18,111.49				

OMI Segment 5 NESP Mech - Elect Construction Project - WRC Labor/Fringes/Non-Direct Labor Factor for Trans Dates - 1/29/2021 - 2/25/2022									
WOID	Date Entered	Date Worked	Name/Description	Hours/Units	Cost	Cost Category	Assign Equipment	Project	Activity
984656	02/07/22	01/18/22	BROWN, JOEL	1.50	0.60	ASSIGNED	Cell Phone	10000003309	ENG
984656	02/07/22	01/18/22	BROWN, JOEL	1.50	3.51	ASSIGNED	PC/Computer	10000003309	ENG
984656	02/07/22	01/18/22	BROWN, JOEL	1.50	0.38	ASSIGNED	Tablet/iPad	10000003309	ENG
984656	02/07/22	01/19/22	BROWN, JOEL	2.00	0.80	ASSIGNED	Cell Phone	10000003309	ENG
984656	02/07/22	01/19/22	BROWN, JOEL	2.00	4.68	ASSIGNED	PC/Computer	10000003309	ENG
984656	02/07/22	01/19/22	BROWN, JOEL	2.00	0.50	ASSIGNED	Tablet/iPad	10000003309	ENG
984656	02/07/22	01/20/22	BROWN, JOEL	4.00	1.60	ASSIGNED	Cell Phone	10000003309	ENG
984656	02/07/22	01/20/22	BROWN, JOEL	4.00	9.36	ASSIGNED	PC/Computer	10000003309	ENG
984656	02/07/22	01/20/22	BROWN, JOEL	4.00	1.00	ASSIGNED	Tablet/iPad	10000003309	ENG
984656	02/07/22	01/24/22	BROWN, JOEL	2.00	0.80	ASSIGNED	Cell Phone	10000003309	ENG
984656	02/07/22	01/24/22	BROWN, JOEL	2.00	4.68	ASSIGNED	PC/Computer	10000003309	ENG
984656	02/07/22	01/24/22	BROWN, JOEL	2.00	0.50	ASSIGNED	Tablet/iPad	10000003309	ENG
984656	02/07/22	01/25/22	BROWN, JOEL	2.00	0.80	ASSIGNED	Cell Phone	10000003309	ENG
984656	02/07/22	01/25/22	BROWN, JOEL	2.00	4.68	ASSIGNED	PC/Computer	10000003309	ENG
984656	02/07/22	01/25/22	BROWN, JOEL	2.00	0.50	ASSIGNED	Tablet/iPad	10000003309	ENG
984656	02/07/22	01/26/22	BROWN, JOEL	2.50	1.00	ASSIGNED	Cell Phone	10000003309	ENG
984656	02/07/22	01/26/22	BROWN, JOEL	2.50	5.85	ASSIGNED	PC/Computer	10000003309	ENG
984656	02/07/22	01/26/22	BROWN, JOEL	2.50	0.63	ASSIGNED	Tablet/iPad	10000003309	ENG
984656	02/07/22	01/27/22	BROWN, JOEL	4.00	1.60	ASSIGNED	Cell Phone	10000003309	ENG
984656	02/07/22	01/27/22	BROWN, JOEL	4.00	9.36	ASSIGNED	PC/Computer	10000003309	ENG
984656	02/07/22	01/27/22	BROWN, JOEL	4.00	1.00	ASSIGNED	Tablet/iPad	10000003309	ENG
984656	02/07/22	01/28/22	BROWN, JOEL	1.00	0.40	ASSIGNED	Cell Phone	10000003309	ENG
984656	02/07/22	01/28/22	BROWN, JOEL	1.00	2.34	ASSIGNED	PC/Computer	10000003309	ENG
984656	02/07/22	01/28/22	BROWN, JOEL	1.00	0.25	ASSIGNED	Tablet/iPad	10000003309	ENG
984656	02/16/22	01/31/22	BROWN, JOEL	1.50	0.60	ASSIGNED	Cell Phone	10000003309	ENG
984656	02/16/22	01/31/22	BROWN, JOEL	1.50	3.51	ASSIGNED	PC/Computer	10000003309	ENG
984656	02/16/22	01/31/22	BROWN, JOEL	1.50	0.38	ASSIGNED	Tablet/iPad	10000003309	ENG
984656	02/16/22	02/01/22	BROWN, JOEL	2.00	0.80	ASSIGNED	Cell Phone	10000003309	ENG
984656	02/16/22	02/01/22	BROWN, JOEL	2.00	4.68	ASSIGNED	PC/Computer	10000003309	ENG
984656	02/16/22	02/01/22	BROWN, JOEL	2.00	0.50	ASSIGNED	Tablet/iPad	10000003309	ENG
984656	02/16/22	02/02/22	BROWN, JOEL	1.00	0.40	ASSIGNED	Cell Phone	10000003309	ENG
984656	02/16/22	02/02/22	BROWN, JOEL	1.00	2.34	ASSIGNED	PC/Computer	10000003309	ENG
984656	02/16/22	02/02/22	BROWN, JOEL	1.00	0.25	ASSIGNED	Tablet/iPad	10000003309	ENG
984656	02/16/22	02/03/22	BROWN, JOEL	1.50	0.60	ASSIGNED	Cell Phone	10000003309	ENG
984656	02/16/22	02/03/22	BROWN, JOEL	1.50	3.51	ASSIGNED	PC/Computer	10000003309	ENG
984656	02/16/22	02/03/22	BROWN, JOEL	1.50	0.38	ASSIGNED	Tablet/iPad	10000003309	ENG
984656	02/16/22	02/07/22	BROWN, JOEL	2.00	0.80	ASSIGNED	Cell Phone	10000003309	ENG
984656	02/16/22	02/07/22	BROWN, JOEL	2.00	4.68	ASSIGNED	PC/Computer	10000003309	ENG
984656	02/16/22	02/07/22	BROWN, JOEL	2.00	0.50	ASSIGNED	Tablet/iPad	10000003309	ENG
984656	02/16/22	02/10/22	BROWN, JOEL	3.00	1.20	ASSIGNED	Cell Phone	10000003309	ENG
984656	02/16/22	02/10/22	BROWN, JOEL	3.00	7.02	ASSIGNED	PC/Computer	10000003309	ENG
984656	02/16/22	02/10/22	BROWN, JOEL	3.00	0.75	ASSIGNED	Tablet/iPad	10000003309	ENG
			BROWN, JOEL Total		89.72				
1050210	02/01/22	01/31/22	CARLEY, JOSEPH	1.00	5.69	ASSIGNED	3/4 Ton Pick-up	10000003309	INS
1050210	02/01/22	01/31/22	CARLEY, JOSEPH	1.00	0.40	ASSIGNED	Cell Phone	10000003309	INS
1050210	02/01/22	01/31/22	CARLEY, JOSEPH	1.00	2.34	ASSIGNED	PC/Computer	10000003309	INS
1050210	02/08/22	02/07/22	CARLEY, JOSEPH	1.00	5.69	ASSIGNED	3/4 Ton Pick-up	10000003309	INS
1050210	02/08/22	02/07/22	CARLEY, JOSEPH	1.00	0.40	ASSIGNED	Cell Phone	10000003309	INS
1050210	02/08/22	02/07/22	CARLEY, JOSEPH	1.00	2.34	ASSIGNED	PC/Computer	10000003309	INS
1050210	02/18/22	02/18/22	CARLEY, JOSEPH	2.00	11.38	ASSIGNED	3/4 Ton Pick-up	10000003309	INS
1050210	02/18/22	02/18/22	CARLEY, JOSEPH	2.00	0.80	ASSIGNED	Cell Phone	10000003309	INS
1050210	02/18/22	02/18/22	CARLEY, JOSEPH	2.00	4.68	ASSIGNED	PC/Computer	10000003309	INS
1050210	02/22/22	02/22/22	CARLEY, JOSEPH	1.00	5.69	ASSIGNED	3/4 Ton Pick-up	10000003309	INS
1050210	02/22/22	02/22/22	CARLEY, JOSEPH	1.00	0.40	ASSIGNED	Cell Phone	10000003309	INS
1050210	02/22/22	02/22/22	CARLEY, JOSEPH	1.00	2.34	ASSIGNED	PC/Computer	10000003309	INS
			CARLEY, JOSEPH Total		42.15				
984656	02/15/22	02/01/22	LOCKHART, SIDNEY	2.00	11.38	ASSIGNED	Blazer/Suburbans	10000003309	ENG
984656	02/15/22	02/01/22	LOCKHART, SIDNEY	2.00	0.80	ASSIGNED	Cell Phone	10000003309	ENG
984656	02/15/22	02/01/22	LOCKHART, SIDNEY	2.00	4.68	ASSIGNED	PC/Computer	10000003309	ENG
984656	02/15/22	02/01/22	LOCKHART, SIDNEY	2.00	0.50	ASSIGNED	Tablet/iPad	10000003309	ENG
984656	02/15/22	02/04/22	LOCKHART, SIDNEY	2.00	11.38	ASSIGNED	Blazer/Suburbans	10000003309	ENG
984656	02/15/22	02/04/22	LOCKHART, SIDNEY	2.00	0.80	ASSIGNED	Cell Phone	10000003309	ENG
984656	02/15/22	02/04/22	LOCKHART, SIDNEY	2.00	4.68	ASSIGNED	PC/Computer	10000003309	ENG
984656	02/15/22	02/04/22	LOCKHART, SIDNEY	2.00	0.50	ASSIGNED	Tablet/iPad	10000003309	ENG
984656	02/15/22	02/08/22	LOCKHART, SIDNEY	2.00	11.38	ASSIGNED	Blazer/Suburbans	10000003309	ENG
984656	02/15/22	02/08/22	LOCKHART, SIDNEY	2.00	0.80	ASSIGNED	Cell Phone	10000003309	ENG
984656	02/15/22	02/08/22	LOCKHART, SIDNEY	2.00	4.68	ASSIGNED	PC/Computer	10000003309	ENG
984656	02/15/22	02/08/22	LOCKHART, SIDNEY	2.00	0.50	ASSIGNED	Tablet/iPad	10000003309	ENG
			LOCKHART, SIDNEY Total		52.08				
1050210	02/01/22	01/31/22	ROBERTS, PATRICK	2.00	11.38	ASSIGNED	1/2 Ton Pick-up	10000003309	INS
1050210	02/01/22	01/31/22	ROBERTS, PATRICK	8.00	45.52	ASSIGNED	1/2 Ton Pick-up	10000003309	INS

1050210	02/16/22	02/16/22	ROBERTS, PATRICK	1.00	2.34	ASSIGNED	PC/Computer	10000003309	INS
1050210	02/16/22	02/16/22	ROBERTS, PATRICK	8.00	18.72	ASSIGNED	PC/Computer	10000003309	INS
1050210	02/17/22	02/17/22	ROBERTS, PATRICK	6.00	34.14	ASSIGNED	1/2 Ton Pick-up	10000003309	INS
1050210	02/17/22	02/17/22	ROBERTS, PATRICK	6.00	2.40	ASSIGNED	Cell Phone	10000003309	INS
1050210	02/17/22	02/17/22	ROBERTS, PATRICK	6.00	14.04	ASSIGNED	PC/Computer	10000003309	INS
1050210	02/18/22	02/18/22	ROBERTS, PATRICK	8.00	45.52	ASSIGNED	1/2 Ton Pick-up	10000003309	INS
1050210	02/18/22	02/18/22	ROBERTS, PATRICK	1.00	5.69	ASSIGNED	1/2 Ton Pick-up	10000003309	INS
1050210	02/18/22	02/18/22	ROBERTS, PATRICK	8.00	3.20	ASSIGNED	Cell Phone	10000003309	INS
1050210	02/18/22	02/18/22	ROBERTS, PATRICK	1.00	0.40	ASSIGNED	Cell Phone	10000003309	INS
1050210	02/18/22	02/18/22	ROBERTS, PATRICK	8.00	18.72	ASSIGNED	PC/Computer	10000003309	INS
1050210	02/18/22	02/18/22	ROBERTS, PATRICK	1.00	2.34	ASSIGNED	PC/Computer	10000003309	INS
1050210	02/21/22	02/21/22	ROBERTS, PATRICK	9.00	51.21	ASSIGNED	1/2 Ton Pick-up	10000003309	INS
1050210	02/21/22	02/21/22	ROBERTS, PATRICK	9.00	3.60	ASSIGNED	Cell Phone	10000003309	INS
1050210	02/21/22	02/21/22	ROBERTS, PATRICK	9.00	21.06	ASSIGNED	PC/Computer	10000003309	INS
1050210	02/22/22	02/22/22	ROBERTS, PATRICK	1.00	5.69	ASSIGNED	1/2 Ton Pick-up	10000003309	INS
1050210	02/22/22	02/22/22	ROBERTS, PATRICK	8.00	45.52	ASSIGNED	1/2 Ton Pick-up	10000003309	INS
1050210	02/22/22	02/22/22	ROBERTS, PATRICK	1.00	0.40	ASSIGNED	Cell Phone	10000003309	INS
1050210	02/22/22	02/22/22	ROBERTS, PATRICK	8.00	3.20	ASSIGNED	Cell Phone	10000003309	INS
1050210	02/22/22	02/22/22	ROBERTS, PATRICK	8.00	18.72	ASSIGNED	PC/Computer	10000003309	INS
1050210	02/22/22	02/22/22	ROBERTS, PATRICK	1.00	2.34	ASSIGNED	PC/Computer	10000003309	INS
1050210	02/23/22	02/23/22	ROBERTS, PATRICK	1.00	5.69	ASSIGNED	1/2 Ton Pick-up	10000003309	INS
1050210	02/23/22	02/23/22	ROBERTS, PATRICK	8.00	45.52	ASSIGNED	1/2 Ton Pick-up	10000003309	INS
1050210	02/23/22	02/23/22	ROBERTS, PATRICK	1.00	0.40	ASSIGNED	Cell Phone	10000003309	INS
1050210	02/23/22	02/23/22	ROBERTS, PATRICK	8.00	3.20	ASSIGNED	Cell Phone	10000003309	INS
1050210	02/23/22	02/23/22	ROBERTS, PATRICK	1.00	2.34	ASSIGNED	PC/Computer	10000003309	INS
1050210	02/23/22	02/23/22	ROBERTS, PATRICK	8.00	18.72	ASSIGNED	PC/Computer	10000003309	INS
1050210	02/24/22	02/24/22	ROBERTS, PATRICK	8.00	45.52	ASSIGNED	1/2 Ton Pick-up	10000003309	INS
1050210	02/24/22	02/24/22	ROBERTS, PATRICK	1.00	5.69	ASSIGNED	1/2 Ton Pick-up	10000003309	INS
1050210	02/24/22	02/24/22	ROBERTS, PATRICK	8.00	3.20	ASSIGNED	Cell Phone	10000003309	INS
1050210	02/24/22	02/24/22	ROBERTS, PATRICK	1.00	0.40	ASSIGNED	Cell Phone	10000003309	INS
1050210	02/24/22	02/24/22	ROBERTS, PATRICK	8.00	18.72	ASSIGNED	PC/Computer	10000003309	INS
1050210	02/24/22	02/24/22	ROBERTS, PATRICK	1.00	2.34	ASSIGNED	PC/Computer	10000003309	INS
1050210	02/25/22	02/25/22	ROBERTS, PATRICK	1.00	5.69	ASSIGNED	1/2 Ton Pick-up	10000003309	INS
1050210	02/25/22	02/25/22	ROBERTS, PATRICK	8.00	45.52	ASSIGNED	1/2 Ton Pick-up	10000003309	INS
1050210	02/25/22	02/25/22	ROBERTS, PATRICK	1.00	0.40	ASSIGNED	Cell Phone	10000003309	INS
1050210	02/25/22	02/25/22	ROBERTS, PATRICK	8.00	3.20	ASSIGNED	Cell Phone	10000003309	INS
1050210	02/25/22	02/25/22	ROBERTS, PATRICK	1.00	2.34	ASSIGNED	PC/Computer	10000003309	INS
1050210	02/25/22	02/25/22	ROBERTS, PATRICK	8.00	18.72	ASSIGNED	PC/Computer	10000003309	INS
			ROBERTS, PATRICK Total		1,525.83				
			Grand Total		1,709.78				

OMI Segment 5 NI-EA Construction Project - WRC Labor/Fringes/Non-Direct Labor Factor for Trans Dates - 1/29/2022 - 2/25/2022									
WOID	Date Entered	Date Worked	Name/Description	Hours/Units	Cost	Cost Category	Assign Equipment	Project	Activity
984657	2/7/22	1/18/22	BROWN, JOEL	1.50	188.18	REGULAR	WRCCON	100000003308	ENG
984657	2/7/22	1/19/22	BROWN, JOEL	2.00	250.90	REGULAR	WRCCON	100000003308	ENG
984657	2/7/22	1/24/22	BROWN, JOEL	0.50	62.73	REGULAR	WRCCON	100000003308	ENG
984657	2/7/22	1/25/22	BROWN, JOEL	1.00	125.45	REGULAR	WRCCON	100000003308	ENG
984657	2/7/22	1/26/22	BROWN, JOEL	2.00	250.90	REGULAR	WRCCON	100000003308	ENG
984657	2/7/22	1/28/22	BROWN, JOEL	0.50	62.73	REGULAR	WRCCON	100000003308	ENG
984657	2/16/22	1/31/22	BROWN, JOEL	1.50	188.18	REGULAR	WRCCON	100000003308	ENG
984657	2/16/22	2/1/22	BROWN, JOEL	2.00	250.90	REGULAR	WRCCON	100000003308	ENG
984657	2/16/22	2/2/22	BROWN, JOEL	1.00	125.45	REGULAR	WRCCON	100000003308	ENG
984657	2/16/22	2/3/22	BROWN, JOEL	1.50	188.18	REGULAR	WRCCON	100000003308	ENG
984657	2/16/22	2/7/22	BROWN, JOEL	2.50	313.63	REGULAR	WRCCON	100000003308	ENG
984657	2/16/22	2/11/22	BROWN, JOEL	2.00	250.90	REGULAR	WRCCON	100000003308	ENG
			BROWN, JOEL Total		2,258.13				
984657	2/15/22	1/31/22	LOCKHART, SIDNEY	1.00	136.37	REGULAR	WRCADM	100000003308	ENG
984657	2/15/22	2/1/22	LOCKHART, SIDNEY	1.00	136.37	REGULAR	WRCADM	100000003308	ENG
984657	2/15/22	2/2/22	LOCKHART, SIDNEY	2.00	272.74	REGULAR	WRCADM	100000003308	ENG
984657	2/15/22	2/3/22	LOCKHART, SIDNEY	3.00	409.11	REGULAR	WRCADM	100000003308	ENG
984657	2/15/22	2/4/22	LOCKHART, SIDNEY	2.00	272.74	REGULAR	WRCADM	100000003308	ENG
984657	2/15/22	2/7/22	LOCKHART, SIDNEY	1.00	136.37	REGULAR	WRCADM	100000003308	ENG
984657	2/15/22	2/8/22	LOCKHART, SIDNEY	2.00	272.74	REGULAR	WRCADM	100000003308	ENG
			LOCKHART, SIDNEY Total		1,636.44				
			Grand Total		3,894.57				

OMI Segment 5 NI-EA Construction Project - WRC Labor/Fringes/Non-Direct Labor Factor for Trans Dates - 1/29/2022 - 2/25/2022									
WOID	Date Entered	Date Worked	Name/Description	Hours/Units	Cost	Cost Category	Assign Equipment	Project	Activity
984657	2/7/22	1/18/22	BROWN, JOEL	1.50	0.38	ASSIGNED	Tablet/iPad	100000003308	ENG
984657	2/7/22	1/18/22	BROWN, JOEL	1.50	0.60	ASSIGNED	Cell Phone	100000003308	ENG
984657	2/7/22	1/18/22	BROWN, JOEL	1.50	3.51	ASSIGNED	PC/Computer	100000003308	ENG
984657	2/7/22	1/19/22	BROWN, JOEL	2.00	4.68	ASSIGNED	PC/Computer	100000003308	ENG
984657	2/7/22	1/19/22	BROWN, JOEL	2.00	0.50	ASSIGNED	Tablet/iPad	100000003308	ENG
984657	2/7/22	1/19/22	BROWN, JOEL	2.00	0.80	ASSIGNED	Cell Phone	100000003308	ENG
984657	2/7/22	1/24/22	BROWN, JOEL	0.50	0.20	ASSIGNED	Cell Phone	100000003308	ENG
984657	2/7/22	1/24/22	BROWN, JOEL	0.50	0.13	ASSIGNED	Tablet/iPad	100000003308	ENG
984657	2/7/22	1/24/22	BROWN, JOEL	0.50	1.17	ASSIGNED	PC/Computer	100000003308	ENG
984657	2/7/22	1/25/22	BROWN, JOEL	1.00	0.25	ASSIGNED	Tablet/iPad	100000003308	ENG
984657	2/7/22	1/25/22	BROWN, JOEL	1.00	2.34	ASSIGNED	PC/Computer	100000003308	ENG
984657	2/7/22	1/25/22	BROWN, JOEL	1.00	0.40	ASSIGNED	Cell Phone	100000003308	ENG
984657	2/7/22	1/26/22	BROWN, JOEL	2.00	0.80	ASSIGNED	Cell Phone	100000003308	ENG
984657	2/7/22	1/26/22	BROWN, JOEL	2.00	4.68	ASSIGNED	PC/Computer	100000003308	ENG
984657	2/7/22	1/26/22	BROWN, JOEL	2.00	0.50	ASSIGNED	Tablet/iPad	100000003308	ENG
984657	2/7/22	1/28/22	BROWN, JOEL	0.50	1.17	ASSIGNED	PC/Computer	100000003308	ENG
984657	2/7/22	1/28/22	BROWN, JOEL	0.50	0.20	ASSIGNED	Cell Phone	100000003308	ENG
984657	2/7/22	1/28/22	BROWN, JOEL	0.50	0.13	ASSIGNED	Tablet/iPad	100000003308	ENG
984657	2/16/22	1/31/22	BROWN, JOEL	1.50	0.60	ASSIGNED	Cell Phone	100000003308	ENG
984657	2/16/22	1/31/22	BROWN, JOEL	1.50	3.51	ASSIGNED	PC/Computer	100000003308	ENG
984657	2/16/22	1/31/22	BROWN, JOEL	1.50	0.38	ASSIGNED	Tablet/iPad	100000003308	ENG
984657	2/16/22	2/1/22	BROWN, JOEL	2.00	0.80	ASSIGNED	Cell Phone	100000003308	ENG
984657	2/16/22	2/1/22	BROWN, JOEL	2.00	4.68	ASSIGNED	PC/Computer	100000003308	ENG
984657	2/16/22	2/1/22	BROWN, JOEL	2.00	0.50	ASSIGNED	Tablet/iPad	100000003308	ENG
984657	2/16/22	2/2/22	BROWN, JOEL	1.00	0.40	ASSIGNED	Cell Phone	100000003308	ENG
984657	2/16/22	2/2/22	BROWN, JOEL	1.00	2.34	ASSIGNED	PC/Computer	100000003308	ENG
984657	2/16/22	2/2/22	BROWN, JOEL	1.00	0.25	ASSIGNED	Tablet/iPad	100000003308	ENG
984657	2/16/22	2/3/22	BROWN, JOEL	1.50	3.51	ASSIGNED	PC/Computer	100000003308	ENG
984657	2/16/22	2/3/22	BROWN, JOEL	1.50	0.60	ASSIGNED	Cell Phone	100000003308	ENG
984657	2/16/22	2/3/22	BROWN, JOEL	1.50	0.38	ASSIGNED	Tablet/iPad	100000003308	ENG
984657	2/16/22	2/7/22	BROWN, JOEL	2.50	0.63	ASSIGNED	Tablet/iPad	100000003308	ENG
984657	2/16/22	2/7/22	BROWN, JOEL	2.50	5.85	ASSIGNED	PC/Computer	100000003308	ENG
984657	2/16/22	2/7/22	BROWN, JOEL	2.50	1.00	ASSIGNED	Cell Phone	100000003308	ENG
984657	2/16/22	2/11/22	BROWN, JOEL	2.00	0.80	ASSIGNED	Cell Phone	100000003308	ENG
984657	2/16/22	2/11/22	BROWN, JOEL	2.00	4.68	ASSIGNED	PC/Computer	100000003308	ENG
984657	2/16/22	2/11/22	BROWN, JOEL	2.00	0.50	ASSIGNED	Tablet/iPad	100000003308	ENG
			BROWN, JOEL Total		53.85				
984657	2/15/22	1/31/22	LOCKHART, SIDNEY	1.00	0.25	ASSIGNED	Tablet/iPad	100000003308	ENG
984657	2/15/22	1/31/22	LOCKHART, SIDNEY	1.00	5.69	ASSIGNED	Blazer/Suburbans	100000003308	ENG
984657	2/15/22	1/31/22	LOCKHART, SIDNEY	1.00	0.40	ASSIGNED	Cell Phone	100000003308	ENG
984657	2/15/22	1/31/22	LOCKHART, SIDNEY	1.00	2.34	ASSIGNED	PC/Computer	100000003308	ENG
984657	2/15/22	2/1/22	LOCKHART, SIDNEY	1.00	2.34	ASSIGNED	PC/Computer	100000003308	ENG
984657	2/15/22	2/1/22	LOCKHART, SIDNEY	1.00	0.40	ASSIGNED	Cell Phone	100000003308	ENG
984657	2/15/22	2/1/22	LOCKHART, SIDNEY	1.00	0.25	ASSIGNED	Tablet/iPad	100000003308	ENG
984657	2/15/22	2/1/22	LOCKHART, SIDNEY	1.00	5.69	ASSIGNED	Blazer/Suburbans	100000003308	ENG
984657	2/15/22	2/2/22	LOCKHART, SIDNEY	2.00	0.50	ASSIGNED	Tablet/iPad	100000003308	ENG
984657	2/15/22	2/2/22	LOCKHART, SIDNEY	2.00	11.38	ASSIGNED	Blazer/Suburbans	100000003308	ENG
984657	2/15/22	2/2/22	LOCKHART, SIDNEY	2.00	4.68	ASSIGNED	PC/Computer	100000003308	ENG
984657	2/15/22	2/2/22	LOCKHART, SIDNEY	2.00	0.80	ASSIGNED	Cell Phone	100000003308	ENG
984657	2/15/22	2/3/22	LOCKHART, SIDNEY	3.00	0.75	ASSIGNED	Tablet/iPad	100000003308	ENG
984657	2/15/22	2/3/22	LOCKHART, SIDNEY	3.00	1.20	ASSIGNED	Cell Phone	100000003308	ENG
984657	2/15/22	2/3/22	LOCKHART, SIDNEY	3.00	17.07	ASSIGNED	Blazer/Suburbans	100000003308	ENG
984657	2/15/22	2/3/22	LOCKHART, SIDNEY	3.00	7.02	ASSIGNED	PC/Computer	100000003308	ENG
984657	2/15/22	2/4/22	LOCKHART, SIDNEY	2.00	11.38	ASSIGNED	Blazer/Suburbans	100000003308	ENG
984657	2/15/22	2/4/22	LOCKHART, SIDNEY	2.00	4.68	ASSIGNED	PC/Computer	100000003308	ENG
984657	2/15/22	2/4/22	LOCKHART, SIDNEY	2.00	0.80	ASSIGNED	Cell Phone	100000003308	ENG
984657	2/15/22	2/4/22	LOCKHART, SIDNEY	2.00	0.50	ASSIGNED	Tablet/iPad	100000003308	ENG
984657	2/15/22	2/7/22	LOCKHART, SIDNEY	1.00	0.25	ASSIGNED	Tablet/iPad	100000003308	ENG
984657	2/15/22	2/7/22	LOCKHART, SIDNEY	1.00	5.69	ASSIGNED	Blazer/Suburbans	100000003308	ENG
984657	2/15/22	2/7/22	LOCKHART, SIDNEY	1.00	0.40	ASSIGNED	Cell Phone	100000003308	ENG
984657	2/15/22	2/7/22	LOCKHART, SIDNEY	1.00	2.34	ASSIGNED	PC/Computer	100000003308	ENG
984657	2/15/22	2/8/22	LOCKHART, SIDNEY	2.00	0.80	ASSIGNED	Cell Phone	100000003308	ENG
984657	2/15/22	2/8/22	LOCKHART, SIDNEY	2.00	4.68	ASSIGNED	PC/Computer	100000003308	ENG
984657	2/15/22	2/8/22	LOCKHART, SIDNEY	2.00	11.38	ASSIGNED	Blazer/Suburbans	100000003308	ENG
984657	2/15/22	2/8/22	LOCKHART, SIDNEY	2.00	0.50	ASSIGNED	Tablet/iPad	100000003308	ENG
			LOCKHART, SIDNEY Total		104.16				
			Grand Total		158.01				



Applied Science, Inc.

300 River Place Suite 5400 Detroit, MI 48207
Phone: (313) 567-3990 Fax: (313) 567-3750
www.asi-detroit.com

March 7, 2022

Project Invoice #37 (ASI Inv. #8057)

Joel Brown, P.E.
Civil Engineer III
Oakland County Water Resources Commissioner's Office
One Public Works Drive, Building 95 West
Waterford, MI 48328

Re: Northeast Sanitary Pump Station
Contract #5470
(ASI Job No. 1815)

li # 41133 v#352

Invoice Period: 1/30/22-2/26/22

Task No.	Task Description	Total This Invoice
1	Transition & Basis of Design	
	Total:	\$ -

Task No.	Task Description	Total This Invoice
2	Design Services for Pump & Electrical Upgrades	
	Total:	\$ -
	Subconsultants:	
	FK Engineering:	\$ -
	NTH Consultants	\$ -
	ASI Markup 5%:	\$ -
	Total Due This Invoice:	\$ -

Task No.	Task Description	Total This Invoice
3	Additional Special Services	
	Total:	\$ -
	Subconsultants:	
	FK Engineering:	\$ -
	ASI Markup 5%:	\$ -
	Total Due This Invoice:	\$ -

Task No.	Task Description	Total This Invoice
5	Construction Services	
	Total:	\$ 11,302.00
	Subconsultants:	
	NTH Consultants	\$ 33,127.90
	Metco Services	\$ 21,765.00
	FK Engineering:	\$ 3,448.00
	ASI Markup 5%:	\$ 2,917.05
	Total Due This Invoice:	\$ 72,559.95

Total Due This Invoice:	\$ 72,559.95
Previous Amount Invoiced:	\$ 2,827,862.41
Total Invoiced To-Date	\$ 2,900,422.36
Contract Task Total:	\$ 4,198,380.00
Amount Remaining:	\$ 1,297,957.65

84917-149015-730639-1-3309 engcon



LG Design is a Subsidiary of CH2M Hill Engineers

Oakland-Macomb Interceptor Drain Drainage District
Oakland County Water Resources Commissioner
One Public Works Drive
Waterford, MI 48328
248-858-0958

Invoice Contact:
Sandy.Pepper@jacobs.com

Remit to:

LG Design, Inc.
Attn: Judy Rives
1041 East Butler Road
Greenville, SC. 29607
Tax ID : 20-0936384

**82912 - 6010101 - 149090 - 730639 - 5456 - Ch 21 - v#22147-
exp. 6/26/23 - li#41407**

3/8/22

Invoice Date: 2/1/2022
CH2M HILL Project No.: 705773CH
CH2M HILL Invoice No.: 705773CH036
Sequential Invoice Number: 37

**PROFESSIONAL SERVICES RENDERED FOR THE OAKLAND-MACOMB INTERCEPTOR DRAIN DRAINAGE DISTRICT (OMIDD)
BIOTRICKLING FILTER DESIGN AND CONSTRUCTION OVERSIGHT**
This invoice includes labor and expenses for the period:
From January 1, 2022 through January 28, 2022

Authorized Amount: \$ 1,272,470.46
Current Invoice: \$ 4,409.10
Total Invoiced: \$ 1,251,302.44
Percent Complete: 98.34%
Remaining Budget: \$ 21,168.02

Total Amount Due: \$ 4,409.10

Project/Task Number	Description	Total Budget	Previously Invoiced	Current Invoice	Total Invoiced	Percent Spent	Remaining Budget
1	PROJECT MANAGEMENT	\$ 33,527.00	\$ 33,504.07	\$ -	\$ 33,504.07	99.93%	\$ 22.93
2	PRELIMINARY DESIGN	\$ 73,599.00	\$ 73,519.37	\$ -	\$ 73,519.37	99.89%	\$ 79.63
3	FINAL DESIGN	\$ 195,027.00	\$ 195,009.84	\$ -	\$ 195,009.84	99.99%	\$ 17.16
4	BIDDING	\$ 31,841.46	\$ 31,840.94	\$ -	\$ 31,840.94	100.00%	\$ 0.52
5	CONSTRUCTION OBSERVATION	\$ 325,731.16	\$ 325,711.92	\$ -	\$ 325,711.92	99.99%	\$ 19.24
6	REVIEW SUBMITTALS	\$ 85,648.00	\$ 85,581.87	\$ -	\$ 85,581.87	99.92%	\$ 66.13
7	CHANGES & CLAIMS	\$ 17,361.00	\$ 17,274.11	\$ -	\$ 17,274.11	99.50%	\$ 86.89
8	SITE INSPECTION	\$ 31,998.07	\$ 31,975.53	\$ -	\$ 31,975.53	99.93%	\$ 22.54
9	PREPARE O&M MANUAL	\$ 21,715.50	\$ 21,695.78	\$ -	\$ 21,695.78	99.91%	\$ 19.72
10	PROVIDE OPERATING TRAINING	\$ 9,082.00	\$ 8,959.07	\$ -	\$ 8,959.07	98.65%	\$ 122.93
11	ASSIST WITH FACILITY START-UP	\$ 17,129.00	\$ 16,875.00	\$ 254.00	\$ 17,129.00	100.00%	\$ -
12	PREPARE RECORD DRAWINGS	\$ 9,803.00	\$ 9,076.43	\$ 726.57	\$ 9,803.00	100.00%	\$ -
13	WARRANTY & PERFORMANCE REVIEWS	\$ 15,370.00	\$ 15,258.58	\$ 94.34	\$ 15,352.92	99.89%	\$ 17.08
14	PROJECT PLANNING	\$ 25,000.00	\$ 24,997.75	\$ -	\$ 24,997.75	99.99%	\$ 2.25
EX	EXPENSES	\$ 17,175.62	\$ 17,175.62	\$ -	\$ 17,175.62	100.00%	\$ -
SUB.METCO	ELECTRICAL ENGINEERING	\$ 74,194.50	\$ 74,194.50	\$ -	\$ 74,194.50	100.00%	\$ -
SUB.NTH	GEOTECH INVESTIGATION	\$ 262,327.15	\$ 262,327.15	\$ -	\$ 262,327.15	100.00%	\$ -
SUB.SDA	SITE SURVEY	\$ 5,250.00	\$ 5,250.00	\$ -	\$ 5,250.00	100.00%	\$ -
Subtotal:		\$ 1,251,779.46	\$ 1,250,227.53	\$ 1,074.91	\$ 1,251,302.44	99.96%	\$ 477.02
Allowance		\$ 20,691.00	\$ -	\$ 3,334.19	\$ 3,334.19	16.11%	\$ 17,356.81
Total:		\$ 1,272,470.46	\$ 1,250,227.53	\$ 4,409.10	\$ 1,254,636.63	116.08%	\$ 17,833.83

OUTSTANDING INVOICES:

INVOICE DATE	INVOICE #	AMOUNT
Total:		\$ -
Current invoice		\$ 4,409.10
TOTAL DUE:		\$ 4,409.10

Payment term: 30 calendar days (NET)

FINANCE CHARGES WILL BE ASSESSED AT 1½ PERCENT PER MONTH (OR MAXIMUM PERMISSIBLE UNDER STATE LAW) ON ALL ACCOUNTS OVERDUE UNLESS STATED OTHERWISE IN OUR CONTRACT. CH2M HILL IS INCORPORATED.

Electronic payment details:

Beneficiary Bank: **Bank of America**
Account Name: **CH2M HILL Engineers, Inc.**
Transit for ACH: **111000012**
Transit for Wires: **026009593**
Account No (USD): **4451457732**
SWIFT: **BOFAUS3N**



Invoice date: 2/1/2022
Project Number: 705773CH
Sequential Invoice Number: 37
Invoice Number: 705773CH036

ASSIST WITH FACILITY START-UP

Employee Name	Project Role	Hours	Rate	Bill Amount
Hill, Michael James	Project Engineer	8.00	\$ 137.96	\$ 1,103.68
Matteo, Jason	Project Manager	1.50	\$ 283.33	\$ 424.99
Matteo, Jason	Project Manager	2.60	\$ 291.83	\$ 759.39
Schreiber, Alexander	Project Engineer I	12.00	\$ 103.23	\$ 1,238.76

Description	Bill Amount
None this period	\$ -

Total Amount This Task: \$ 3,526.82

CLARK HILL

P.L.C.

ATTORNEYS AT LAW

212 East Grand River Avenue
Lansing, Michigan 48906-4328
Telephone (517) 318-3100
Fed.ID # 38-0425840

INVOICE

Invoice # 1174160

Oakland-Macomb Interceptor Drain Drainage District February 10, 2022
Attn: Megan Koss, Esq. Client: 58434
1 Public Works Drive Matter: 404547
Waterford, MI 48328
WRClegalinvoices@oakgov.com

=====

RE: Northeast Interceptor East Arm Improvements

FOR SERVICES RENDERED through January 31, 2022

Total Services: \$5,913.00

INVOICE TOTAL \$5,913.00

**84917 - 149015 - 731073 - 1-3308 - LEGAL - 5113 -
v#2788 - li#39308 - exp. 5/15/22**



3/8/22

PAYABLE UPON RECEIPT IN U.S. DOLLARS

CLARK HILL

P.L.C.

ATTORNEYS AT LAW

212 East Grand River Avenue
Lansing, Michigan 48906-4328
Telephone (517) 318-3100
Fed.ID # 38-0425840

INVOICE

Invoice # 1174161

Oakland-Macomb Interceptor Drain Drainage District February 10, 2022
Attn: Megan Koss, Esq. Client: 58434
1 Public Works Drive Matter: 424741
Waterford, MI 48328
WRClegalinvoices@oakgov.com

=====

RE: GLWA Model Wastewater Contract

FOR SERVICES RENDERED through January 31, 2022

Total Services: \$4,698.00

INVOICE TOTAL \$4,698.00

**82912 - 6010101 - 149030 - 731073 -5113 - v#2788
- exp. 5/15/22**



3/8/22

PAYABLE UPON RECEIPT IN U.S. DOLLARS



CSM Mechanical, LLC

1235 Holden Ave.
Milford, MI 48381

Invoice

Date	Invoice #
8/26/2021	21OMIDD002

82912 - 149090 - 730660 - 5817 - Ch. 21 - v# 15750 - exp.
6/28/22 - li# 42697 *Jul Ben* 3/8/22

Bill To
OMIDD One Public Works Drive Building 95 West Waterford, MI 48328

Ship To
OMIDD 11010 E. State Fair St. Detroit, MI

P.O. Number	Terms	Due Date
	Net 60	10/25/2021

Description	Amount
Install 3" Bypass for Bio Trickle Drain	
Labor	1,140.00
Materials	2,265.55
Vehicle/Tool Allowance	75.00
<i>TM</i> 10-20-21	

WE ACCEPT MASTER CARD, VISA, AND DISCOVER CARD

Total	\$3,480.55
Payments/Credits	\$0.00
Balance Due	\$3,480.55

"Relentlessly Helping Our Customers Achieve Success by Being an Integral, Caring and Innovative Mechanical Solutions Provider."



CSM Mechanical, LLC

1235 Holden Ave.
Milford, MI 48381

Phone # (248) 302-2078
Fax # (248) 856-2370

Invoice

Date	Invoice #
12/7/2021	21OMIDD007

82912 - 149090 - 730660 - 5817 - Ch. 21 - v# 15750 - exp.
6/28/22 - li# 42697

Bill To
OMIDD <i>Jul Ben</i> 3/8/22 One Public Works Drive Building 95 West Waterford, MI 48328

Ship To
OMIDD 11010 E. State Fair St. Detroit, MI

P.O. Number	Terms	Due Date
	Net 60	2/5/2022

Description	Amount
Pump 5 Valve Replacement	
Labor	380.00
Vehicle/Tool Allowance	75.00
Materials	107.50
<i>JM - 2 - 15 - 22</i>	

WE ACCEPT MASTER CARD, VISA, AND DISCOVER CARD

Total	\$562.50
Payments/Credits	\$0.00
Balance Due	\$562.50



CSM Mechanical, LLC

1235 Holden Ave.
Milford, MI 48381

Invoice

Date	Invoice #
10/4/2021	21OMIDD009

82912 - 149090 - 730660 - 5817 - Ch. 21 - v# 15750

- exp. 6/28/22 li# 42697 *JL Bm* 3/8/22

Bill To
OMIDD One Public Works Drive Building 95 West Waterford, MI 48328

Ship To
OMIDD 11010 E. State Fair St. Detroit, MI

P.O. Number	Terms	Due Date
	Net 60	12/3/2021

Description	Amount
Fabricate and install 8 Lifting brackets on Wet Well hatch covers Labor	4,961.00
<i>TM</i> 10-20-21	

	Total	\$4,961.00
	Payments/Credits	\$0.00
	Balance Due	\$4,961.00

WE ACCEPT MASTER CARD, VISA, AND DISCOVER CARD

“Relentlessly Helping Our Customers Achieve Success by Being an Integral, Caring and Innovative Mechanical Solutions Provider.”



CSM Mechanical, LLC
 7400 Hickory Valley Dr.
 Fenton, MI 48430

Invoice

Date	Invoice #
6/30/2021	21OMIDD011

82912 - 149090 - 730660 - 5817 - Ch. 21 - v# 15750 - exp.
 6/28/22 - li# 42697 *JL Ben* 3/8/22

Bill To
OMIDD One Public Works Drive Building 95 West Waterford, MI 48328

Ship To
OMIDD 11010 E. State Fair St. Detroit, MI

P.O. Number	Terms	Due Date
	Net 60	8/29/2021

Description	Amount
VFD Repair Services per Subcontractor Details Attached	3,099.26
<i>TM-2-15-22</i>	

Total		\$3,099.26
Payments/Credits		\$0.00
Balance Due		\$3,099.26

WE ACCEPT MASTER CARD, VISA, AND DISCOVER CARD

"Relentlessly Helping Our Customers Achieve Success by Being an Integral, Caring and Innovative Mechanical Solutions Provider."



CSM Mechanical, LLC

1235 Holden Ave.
Milford, MI 48381

Phone # (248) 302-2078
Fax # (248) 856-2370

Invoice

Date	Invoice #
12/7/2021	21OMIDD013

82912 - 149090 - 730660 - 5817 - Ch. 21 - v# 15750
- exp. 6/28/22 - li# 42697

Bill To
OMIDD One Public Works Drive Building 95 West Waterford, MI 48328 <i>JH Ben</i>

Ship To
3/8/22

P.O. Number	Terms	Due Date
	Net 60	2/5/2022

Description	Amount
Pump 6 Pressure Gauge Replacement	
Labor	285.00
Vehicle/Tool Allowance	75.00
Service provided	
Pressure gauge replaced	
<i>TM - 2-15-22</i>	

WE ACCEPT MASTER CARD, VISA, AND DISCOVER CARD

Total	\$360.00
Payments/Credits	\$0.00
Balance Due	\$360.00

Vendor	No.	Description	Unit Price	Total	 CSM MECHANICAL, LLC 7400 HICKORY VALLEY DRIVE FENTON, MI 48430 TEL: 248.521.0981 FAX: 517.540.9704 WWW.CSMMECHANICAL.COM			
				\$0.00				
				\$0.00				
				\$0.00				
				\$0.00				
				\$0.00	CUSTOMER P.O. NO.	DATE OF INVOICE	2/10/2022	CSM JOB #
				\$0.00	CONTACT:	Terry Moore	PHONE NO.	220MIDD-003
				\$0.00	JOB NAME	Perform confined space sump pump discharge hose attachment to wall		
				\$0.00	ADDRESS	11010 State Fair St E Detroit, MI, United States		
				\$0.00	SERVICE REQUESTED OR TROUBLE REPORTED:			
				\$0.00	Sum Pump discharge hose attachment			

ENVIRONMENT CHECK LIST

CHRG. CODE	TYPE REFRIG.	SYS QTY.	EQUIPMENT	CHANGED OUT OR REPLACED? Y/N	N/A						
						1	RECOVERED? Y/N	N/A	QTY.	DIS-MANTLED? Y/N	N/A
						2	RECYCLED? Y/N	N/A	QTY.	REFRIGERATOR DISPOSAL? Y/N	N/A
						3	RECLAIMED? Y/N	N/A	QTY.	OUR PERSONNEL RECOMMENDS	
							RETURNED TO THIS SYSTEM? Y/N	N/A	QTY.	OWNERS INITIALS	
						4	DISPOSAL			ACCEPTED	DECLINED

MAKE	MODEL	SERIAL NO.	WARRANTY
			<input checked="" type="checkbox"/> CONTRACT
			<input type="checkbox"/> SERVICE CONTRACT
			<input type="checkbox"/> NORMAL

SERVICE PERFORMED:
 Disconnect power for safety
 Verify quality air - Confined Space Location
 Secure Sump hose to wall

82912 - 6010101 -149090- 730660 - 6194 - Ch. 21- V#15750 li#44348 exp. 9/30/23

TM 2-15-22 Jd Ben 3/8/22

DATE	SERVICE ENGINEER	HOURS			LABOR AMOUNT	EQUIPMENT RENTAL	MATERIAL	FED REFRIG FEE	TAX	VEH/TOOL ALLOW	TOTAL LABOR	TOTAL
		ST	OT	DT								
1/6/2022	TJ Fields	3			\$285.00							
1/6/2022	Travis Loruss	3			\$285.00							
					\$0.00							
					\$0.00					\$75.00		
					\$0.00						\$570.00	
					\$0.00							
					\$0.00							\$645.00

RECOMMENDATIONS OR ADDITIONAL REPAIRS NEEDED:

PARTS WARRANTY: ALL PARTS AS RECORDED ARE WARRANTED AS PER MANUFACTURER SPECIFICATIONS. LABOR GUARANTY THE LABOR CHARGE AS RECORDED HERE RELATIVE TO THE EQUIPMENT SERVICE AS NOTED IS GUARANTEED FOR A PERIOD OF 30 DAYS, WE DO NOT, OF COURSE GUARANTEE OTHER PARTS THAN THOSE WE INSTALL. IF REPAIRS LATER BECOME NECESSARY DUE TO OTHER DEFECTIVE PARTS, THEY WILL BE CHARGED SEPARATLY.

TERMS NET 10 DAYS.	NOTE: A DELIQUENCY CHARGE OF 1-1/2% PER MONTH (BUT NOT IN EXCESS OF THE LAWFUL MAXIMUM) ON ANY AMOUNT 60 DAYS IN ARREARS IF NOT RECEIVED PRIOR TO THE NEXT MONTHLY BILLING DATE AND THEREAFTER ON ALL AMOUNTS 60 DAYS OR MORE IN ARREARS UNTIL PAID.	CUSTOMERS SIGNATURE	SERVICEMAN SIGNATURE	<input checked="" type="checkbox"/> COMPLETE
			<i>JP</i>	<input type="checkbox"/> INCOMPLETE



Knowledgeable • Professional • Attentive • Likeable

29770 Hudson Drive Novi, MI 48377
Phone: (586) 978-7200
hesco-mi.com

Invoice No. 2213446

Date: 02/11/2022

82912 - 149130 - 730660 - 5819 - Ch. 21 -
v#3091 - exp. 6/30/22 - li#42703

Billed To: OMID Drainage District
1 Public Works Drive
Waterford MI 48328

3/8/22

Project: 2019807S OMID Flow Control Structures

Contact: Terry Moore P.O.# Sewer Fund #149130 Salesperson: David Burkel Due Date: 03/13/2022

Description	Unit	Qty	Rate	Amount
1/29/2022 - Preventative Maintenance and Inspection				
Senior Tech	Hours	11.50	185.00	2,127.50
Tech 1	Hours	9.50	120.00	1,140.00
Tech 1	Hours	9.50	120.00	1,140.00
Tech 1	Hours	9.50	120.00	1,140.00
Parts				
Return Filter	Each	1.00	17.25	17.25
Pressure Filter	Each	1.00	60.00	60.00
Hydraulic Oil, 25 Gallons	Each	1.00	950.00	950.00
Gate Hardware	Total	1.00	150.00	150.00

Notes:

WO 00512 – CS-5 Preventative Maintenance and Inspection.

TM 2-21-22

EFFECTIVE SEPTEMBER 24th, 2021
To keep up with growth, we moved again.
Please update your records.
29770 HUDSON DRIVE
NOVI, MI 48377
586-978-7200

Non-Taxable Amount:	6,724.75
Taxable Amount:	0.00
Sales Tax:	0.00
Total Invoice	6,724.75
Payments/Credits:	0.00
Amount Due	6,724.75



Knowledgeable • Professional • Attentive • Likeable

29770 Hudson Drive Novi, MI 48377
Phone: (586) 978-7200
hesco-mi.com

Invoice No. 2213447

Date: 02/11/2022

82912 - 149090 - 730660 - 5819 - Ch. 21 - v#3091 - exp.
6/30/22 - li#42703

Billed To: OMID Drainage District
1 Public Works Drive
Waterford MI 48328

3/8/22

Project: 2019807S OMID Flow Control Structures

Contact: Terry Moore P.O.# Sewer Fund #149130 Salesperson: David Burkel Due Date: 03/13/2022

Description	Unit	Qty	Rate	Amount
2/1/22 NESPS Wetwell Sensor Troubleshooting				
Senior Tech	Hours	6.50	185.00	1,202.50

Notes:

WO 00525 – NESPS Wetwell Sensor

Work was performed by John Sullens on 2/1/22 – note that other, unrelated work was done at another site on this day that needs to be invoiced separately.

JM 2-14-22

EFFECTIVE SEPTEMBER 24th, 2021
To keep up with growth, we moved again.
Please update your records.
29770 HUDSON DRIVE
NOVI, MI 48377
586-978-7200

Non-Taxable Amount:	1,202.50
Taxable Amount:	0.00
Sales Tax:	0.00
Total Invoice	1,202.50
Payments/Credits:	0.00
Amount Due	1,202.50



Knowledgeable • Professional • Attentive • Likeable
 29770 Hudson Drive Novi, MI 48377
 Phone: (586) 978-7200
 hesco-mi.com

Invoice No. 2213456

Date: 02/17/2022

Billed To: OMID Drainage District
 1 Public Works Drive
 Waterford MI 48328

82912 - 149130 - 730660 - 5819 - Ch. 21 - v#3091
- exp. 6/30/22 - li#42703

3/8/22

Project: 2019807S OMID Flow Control Structures

Contact: Terry Moore **P.O.#** WO# 00511-CS-7 **Salesperson:** David Burkel **Due Date:** 03/19/2022

Description	Unit	Qty	Rate	Amount
2/12/2022 - Preventative Maintenance and Inspection				
Senior Tech	Hours	7.50	185.00	1,387.50
Tech 1	Hours	6.50	120.00	780.00
Tech 1	Hours	6.50	120.00	780.00
Tech 1	Hours	6.50	120.00	780.00
Parts				
Return Filter	Each	1.00	17.25	17.25
Pressure Filter	Each	1.00	60.00	60.00
Hydraulic Oil, 20 Gallons	Each	1.00	760.00	760.00
Gate Hardware	Total	1.00	15.00	15.00

Notes:
 WO 00511 – CS-7 Preventative Maintenance and Inspection.

TM 3-4-22

EFFECTIVE SEPTEMBER 24th, 2021

To keep up with growth, we moved again.
 Please update your records.
 29770 HUDSON DRIVE
 NOVI, MI 48377
 586-978-7200

Non-Taxable Amount:	4,579.75
Taxable Amount:	0.00
Sales Tax:	0.00
Total Invoice	4,579.75
Payments/Credits:	0.00
Amount Due	4,579.75



Invoice No. 20212685

Knowledgeable • Professional • Attentive • Likeable

23905 Freeway Park • Farmington Hills, MI 48335

Phone: 586.978.7200 • Fax: 586.978.2200

www.hesco-mi.com

Date: 02/15/2021

82912 - 149090 - 730660 - 5819 - Ch. 21 - v#3091 - exp. 6/30/22
- li#42703

Billed To: OMID Drainage District
1 Public Works Drive
Waterford MI 48328

3/8/22

Project: S2019807S OMID Flow Control Structures

Contact: Terry Moore

P.O.# Sewer Fund #149130 Salesperson: David Burkel

Due Date: 03/17/2021

Description	Qty	Rate	Amount
OMID Flow Control Structure Maintenance and Repair Contract Sewer Fund #149130			
NEPS #2 Wetwell Level Sensor Troubleshooting on 1/11/21			
Senior Tech	5.750	185.00	1,063.75
Tech 1	4.500	120.00	540.00
Tech 1	4.500	120.00	540.00
CS-5 Hydraulic System Troubleshooting and Gate Service on 1/22/21			
Senior Tech	8.500	185.00	1,572.50
Tech 1	6.000	120.00	720.00
NEXGEN Training on 1/28/21			
Project Manager	0.500	215.00	107.50

TM 2-8-22

We have moved!

Please update your records to reflect our new address
23905 Freeway Park Drive
Farmington Hills, MI 48335

Non-Taxable Amount:	4,543.75
Taxable Amount:	0.00
Sales Tax:	0.00
Amount Due	4,543.75



INVOICE NO. 1811-38

DATE: March 1, 2022

METCO PROJECT NO. 1811

INVOICE PERIOD: 1/31 thru 2/27/2022

Contract ID 00000000000000000000517

Vendor ID 000020486

TO: OMIDD

Water Resources Commissioner
One Public Works Drive
Waterford, MI 48328

Attn: Mr. Sid Lockhart, PE
Deputy Chief Engineer/Special Projects Manager

TITLE: OMID & NESPS Operation and Maintenance

Operational Plan

OMID Operations - Fund 82912, Program 149130, Account 730373 (3.1-3.4A & 3.4B)

Name	Title	Hrs.	Rate/Hr.	Amount
Raj Vijayendran, PE	Principal Engineer	0.0	\$ 215.00	\$ -
Terry Moore	Operations Manager	40.0	\$ 145.00	\$ 5,800.00
Terry Moore	Operations Manager (Overtim	4.0	\$ 195.00	\$ 780.00
Darrin Green	Staff Engineer	39.0	\$ 90.00	\$ 3,510.00
Darrin Green	Staff Engineer-(Overtime)	8.5	\$ 135.00	\$ 1,147.50
Anthony Vozza	Staff Engineer	68.0	\$ 90.00	\$ 6,120.00
Anthony Vozza	Staff Engineer-(Overtime)	0.0	\$ 135.00	\$ -
Rosana Santos	Administrative Assoc.	0.0	\$ 73.79	\$ -
Subtotal OMID Operatons:			\$	17,357.50

NEPS Operations - Fund 82912, Program 149090, Account 730373 (3.1-3.4A & 3.4B)

Name	Title	Hrs.	Rate/Hr.	Amount
Raj Vijayendran, PE	Principal Engineer	8.0	\$ 215.00	\$ 1,720.00
Terry Moore	Operations Manager	40.0	\$ 145.00	\$ 5,800.00
Terry Moore	Operations Manager (Overtim	4.0	\$ 195.00	\$ 780.00
Darrin Green	Staff Engineer	41.0	\$ 90.00	\$ 3,690.00
Darrin Green	Staff Engineer-(Overtime)	0.0	\$ 135.00	\$ -
Anthony Vozza	Staff Engineer	6.0	\$ 90.00	\$ 540.00
Anthony Vozza	Staff Engineer-(Overtime)	0.0	\$ 135.00	\$ -
Rosana Santos	Administrative Assoc.	4.0	\$ 73.79	\$ 295.16
Subtotal NEPS Operations			\$	12,825.16
Subtotal Operations			\$	30,182.66

Maintenance & Asset Management

OMID Maintenance – Fund 82912, Program 149130, Account 730646 (3.2-3.3-3.4C & ALLOWANCE)

Name	Title	Hrs.	Rate/Hr.	Amount
Terry Moore	Operations Manager	0.0	\$ 145.00	\$ -
Terry Moore	Operations Manager (Overtim	40.0	\$ 195.00	\$ 7,800.00
Anthony Vozza	Staff Engineer	0.0	\$ 90.00	\$ -
Darrin Green	Staff Engineer	12.0	\$ 90.00	\$ 1,080.00
Subtotal OMID Maintenance:			\$	8,880.00

NEPS Maintenance – Fund 82912, Program 149090, Account 730646 (3.2-3.3-3.4C & ALLOWANCE)

Name	Title	Hrs.	Rate/Hr.	Amount
Raj Vijayendran, PE	Principal Engineer	8.0	\$ 215.00	\$ 1,720.00
Terry Moore	Operations Manager	40.0	\$ 145.00	\$ 5,800.00
Terry Moore	Operations Manager (Overtim	4.0	\$ 195.00	\$ 780.00
Daniel Martel	Sr. Project Coordinator	0.0	\$ 145.00	\$ -
Sean Grant	Sr. Project Engineer	0.0	\$ 145.00	\$ -

Travis Ford	Sr. Project Engineer	11.0	\$	145.00	\$	1,595.00
Shailesh Patel	Sr. Project Engineer	0.0	\$	145.00	\$	-
Darrin Green	Staff Engineer	40.0	\$	90.00	\$	3,600.00
Darrin Green	Staff Engineer-(Overtime)	4.0	\$	135.00	\$	540.00
Anthony Vozza	Staff Engineer	68.0	\$	90.00	\$	6,120.00
Anthony Vozza	Staff Engineer-(Overtime)	0.0	\$	135.00	\$	-
Brandon Brochue	Designer/Drafter	0.0	\$	85.00	\$	-
	Subtotal:		\$		\$	20,155.00
	Maintenance Services (see attached invoices):		\$		\$	520.67
	Subtotal NEPS Maintenance:		\$		\$	20,675.67
	Subtotal Maintenance:		\$		\$	29,555.67

Task 6.0 NEXGEN Asset Management Implementation Services – #1-2842 Fund 82912, Program 149662, Account 731444 ENGCON

<u>Name</u>	<u>Title</u>	<u>Hrs.</u>		<u>Rate/Hr.</u>		<u>Amount</u>
Raj Vijayendran, PE	Principal Engineer	0.0	\$	215.00	\$	-
Terry Moore	Operations Manager	0.0	\$	145.00	\$	-
Terry Moore	Operations Manager (Overtim	0.0	\$	195.00	\$	-
Sean Grant	Sr. Project Engineer	18.0	\$	145.00	\$	2,610.00
Darrin Green	Staff Engineer	0.0	\$	90.00	\$	-
Darrin Green	Staff Engineer-(Overtime)	0.0	\$	135.00	\$	-
Anthony Vozza	Staff Engineer	0.0	\$	90.00	\$	-
Abhishek Shah	Staff Engineer	90.0	\$	90.00	\$	8,100.00
Brandon Brochue	Designer/Drafter	0.0	\$	85.00	\$	-
	Subtotal 6.0:		\$		\$	10,710.00

Task 12.0 - As-Needed Services

Additional General/Excess Liability Insurance Fee:	\$	-
Subtotal 12.0:	\$	-

TOTAL AMOUNT DUE THIS INVOICE: \$ 70,448.33



INVOICE NO. 1811-37

DATE: February 11, 2022

METCO PROJECT NO. 1811

INVOICE PERIOD: 1/1 thru 1/30/2021

Contract ID 00000000000000000000517

Vendor ID 000020486

TO: OMIDD

Water Resources Commissioner
One Public Works Drive
Waterford, MI 48328

Attn: Mr. Sid Lockhart, PE
Deputy Chief Engineer/Special Projects Manager

TITLE: OMID & NESPS Operation and Maintenance

Operational Plan

OMID Operations - Fund 82912, Program 149130, Account 730373 (3.1-3.4A & 3.4B)

Name	Title	Hrs.	Rate/Hr.	Amount
Raj Vijayendran, PE	Principal Engineer	0.0	\$ 215.00	\$ -
Terry Moore	Operations Manager	40.0	\$ 145.00	\$ 5,800.00
Terry Moore	Operations Manager (Overtim	4.0	\$ 195.00	\$ 780.00
Darrin Green	Staff Engineer	30.0	\$ 90.00	\$ 2,700.00
Darrin Green	Staff Engineer-(Overtime)	17.5	\$ 135.00	\$ 2,362.50
Anthony Vozza	Staff Engineer	39.0	\$ 90.00	\$ 3,510.00
Anthony Vozza	Staff Engineer-(Overtime)	14.0	\$ 135.00	\$ 1,890.00
Rosana Santos	Administrative Assoc.	0.0	\$ 73.79	\$ -
Subtotal OMID Operatons:			\$	17,042.50

NEPS Operations - Fund 82912, Program 149090, Account 730373 (3.1-3.4A & 3.4B)

Name	Title	Hrs.	Rate/Hr.	Amount
Raj Vijayendran, PE	Principal Engineer	8.0	\$ 215.00	\$ 1,720.00
Terry Moore	Operations Manager	40.0	\$ 145.00	\$ 5,800.00
Terry Moore	Operations Manager (Overtim	13.0	\$ 195.00	\$ 2,535.00
Darrin Green	Staff Engineer	31.0	\$ 90.00	\$ 2,790.00
Darrin Green	Staff Engineer-(Overtime)	0.0	\$ 135.00	\$ -
Anthony Vozza	Staff Engineer	9.0	\$ 90.00	\$ 810.00
Anthony Vozza	Staff Engineer-(Overtime)	0.0	\$ 135.00	\$ -
Rosana Santos	Administrative Assoc.	4.0	\$ 73.79	\$ 295.16
Subtotal NEPS Operations			\$	13,950.16
Subtotal Operations			\$	30,992.66

Maintenance & Asset Management

OMID Maintenance – Fund 82912, Program 149130, Account 730646 (3.2-3.3-3.4C & ALLOWANCE)

Name	Title	Hrs.	Rate/Hr.	Amount
Terry Moore	Operations Manager	0.0	\$ 145.00	\$ -
Terry Moore	Operations Manager (Overtim	40.0	\$ 195.00	\$ 7,800.00
Anthony Vozza	Staff Engineer	0.0	\$ 90.00	\$ -
Darrin Green	Staff Engineer	25.0	\$ 90.00	\$ 2,250.00
Subtotal OMID Maintenance:			\$	10,050.00

NEPS Maintenance – Fund 82912, Program 149090, Account 730646 (3.2-3.3-3.4C & ALLOWANCE)

Name	Title	Hrs.	Rate/Hr.	Amount
Raj Vijayendran, PE	Principal Engineer	8.0	\$ 215.00	\$ 1,720.00
Terry Moore	Operations Manager	40.0	\$ 145.00	\$ 5,800.00
Terry Moore	Operations Manager (Overtim	5.0	\$ 195.00	\$ 975.00
Daniel Martel	Sr. Project Coordinator	4.0	\$ 145.00	\$ 580.00
Sean Grant	Sr. Project Engineer	0.0	\$ 145.00	\$ -

Travis Ford	Sr. Project Engineer	0.0	\$	145.00	\$	-
Shailesh Patel	Sr. Project Engineer	0.0	\$	145.00	\$	-
Darrin Green	Staff Engineer	35.0	\$	90.00	\$	3,150.00
Darrin Green	Staff Engineer-(Overtime)	0.0	\$	135.00	\$	-
Anthony Vozza	Staff Engineer	48.0	\$	90.00	\$	4,320.00
Anthony Vozza	Staff Engineer-(Overtime)	8.5	\$	135.00	\$	1,147.50
Brandon Brochue	Designer/Drafter	0.0	\$	85.00	\$	-
Subtotal:					\$	17,692.50
Maintenance Services (see attached invoices):					\$	9,996.97
Subtotal NEPS Maintenance:					\$	27,689.47
Subtotal Maintenance:					\$	37,739.47

Task 6.0 NEXGEN Asset Management Implementation Services – #1-2842 Fund 82912, Program 149662, Account 731444 ENGCON

<u>Name</u>	<u>Title</u>	<u>Hrs.</u>		<u>Rate/Hr.</u>		<u>Amount</u>
Raj Vijayendran, PE	Principal Engineer	0.0	\$	215.00	\$	-
Terry Moore	Operations Manager	0.0	\$	145.00	\$	-
Terry Moore	Operations Manager (Overtim	0.0	\$	195.00	\$	-
Sean Grant	Sr. Project Engineer	17.0	\$	145.00	\$	2,465.00
Darrin Green	Staff Engineer	0.0	\$	90.00	\$	-
Darrin Green	Staff Engineer-(Overtime)	0.0	\$	135.00	\$	-
Anthony Vozza	Staff Engineer	0.0	\$	90.00	\$	-
Abhishek Shah	Staff Engineer	152.0	\$	90.00	\$	13,680.00
Brandon Brochue	Designer/Drafter	0.0	\$	85.00	\$	-
Subtotal 6.0:					\$	16,145.00

Task 12.0 - As-Needed Services

Additional General/Excess Liability Insurance Fee:	\$	-
Subtotal 12.0:	\$	-

TOTAL AMOUNT DUE THIS INVOICE: \$ 84,877.13



MOTOR CITY ELECTRIC TECHNOLOGIES INC.
AUTOMATION AND CONTROLS SOLUTIONS
 9440 GRINNELL
 DETROIT, MI 48213-1151
 PHONE (313) 921-5300 FAX (313) 921-5310
 "AN EQUAL OPPORTUNITY EMPLOYER"

INVOICE

OMID
 ONE PUBLIC WORKS DRIVE, BUILDING 95
 WATERFORD, MI 48328-

Customer
 PO Number

Job Number	Sub Job	Contract Number	Date Performed	Application	
				Date	Number
922567	0	001	1/4/2022	2/2/2022	94246

SID LOCKHART

Item No	Description of Work	Contract Amount	Previous Billings	Current Amount	To Date Complete & Stored	Balance To Finish	Current Retainage
001	NESP SCADA CUTOVER	\$189.00	-	\$189.00	\$189.00	-	-
Totals:		\$189.00		\$189.00	\$189.00		
Less Retained:				-			
Invoice Total:				\$189.00			

AS NEEDED ELECTRICAL AND ENGINEERING SERVICE

SEE ATTACHED INVOICE SUMMARY AND FIELD REPORT

82912 - 6010101 - 149090- 730660 - 5469 - Ch. 21 - v# 7755 - li# 41132 - exp. 12/31/23

WORK PERFORMED 1/4/2022
 CUSTOMER WORK ORDER # 499

Jed Bru

3/8/22

TM-2-15-22

complete electrical construction

"We hereby certify that the articles and services covered by this invoice were produced and performed in compliance with all applicable requirements of Section 6, 7 and 12 of the Fair Labor Standards Act, as amended, and of regulations and orders of the United States Department of Labor issued under Section 14 thereof."



MOTOR CITY ELECTRIC TECHNOLOGIES INC.

AUTOMATION AND CONTROLS SOLUTIONS
9440 GRINNELL
DETROIT, MI 48213-1151
PHONE (313) 921-5300 FAX (313) 921-5310
"AN EQUAL OPPORTUNITY EMPLOYER"

INVOICE

OMID
ONE PUBLIC WORKS DRIVE, BUILDING 95
WATERFORD, MI 48328-

Customer
PO Number

Job Number	Sub Job	Contract Number	Date Performed	Application	
				Date	Number
922567	0	001	1/5/2022	2/2/2022	94247

SID LOCKHART

Item No	Description of Work	Contract Amount	Previous Billings	Current Amount	To Date Complete & Stored	Balance To Finish	Current Retainage
001	NESP SCADA CUTOVER	\$180.00	-	\$180.00	\$180.00	-	-
Totals:		\$180.00		\$180.00	\$180.00		
Less Retained:				-			
Invoice Total:				\$180.00			

AS NEEDED ELECTRICAL AND ENGINEERING SERVICE

SEE ATTACHED INVOICE SUMMARY AND FIELD REPORT

82912 - 6010101 - 149090- 730660 - 5469 - Ch. 21 - v# 7755 - li# 41132 - exp. 12/31/23

WORK PERFORMED 1/5/2022

WORK ORDER #499

3/8/22

TM-2-15-22

complete electrical construction

"We hereby certify that the articles and services covered by this invoice were produced and performed in compliance with all applicable requirements of Section 6, 7 and 12 of the Fair Labor Standards Act, as amended, and of regulations and orders of the United States Department of Labor issued under Section 14 thereof."



MOTOR CITY ELECTRIC TECHNOLOGIES INC.

AUTOMATION AND CONTROLS SOLUTIONS
9440 GRINNELL
DETROIT, MI 48213-1151
PHONE (313) 921-5300 FAX (313) 921-5310
"AN EQUAL OPPORTUNITY EMPLOYER"

INVOICE

OMID
ONE PUBLIC WORKS DRIVE, BUILDING 95
WATERFORD, MI 48328-

Customer
PO Number
WO #00456

Job Number	Sub Job	Contract Number	Date Performed	Application	
				Date	Number
922567	0	001	2/7/2022	2/9/2022	94264

SID LOCKHART

Item No	Description of Work	Contract Amount	Previous Billings	Current Amount	To Date Complete & Stored	Balance To Finish	Current Retainage
001	NESP SCADA CUTOVER	\$725.64	-	\$725.64	\$725.64	-	-
Totals:		\$725.64		\$725.64	\$725.64		
Less Retained:				-			
Invoice Total:				\$725.64			

AS NEEDED ELECTRICAL AND ENGINEERING SERVICE

SEE ATTACHED INVOICE SUMMARY AND FIELD REPORT

82912 - 6010101 - 149130- 730660 - 5469 - Ch. 21 - v# 7755 - li# 41132 - exp. 12/31/23

WORK PERFORMED 2/7/2022

3/8/22

TM 2-9-22

complete electrical construction

"We hereby certify that the articles and services covered by this invoice were produced and performed in compliance with all applicable requirements of Section 6, 7 and 12 of the Fair Labor Standards Act, as amended, and of regulations and orders of the United States Department of Labor issued under Section 14 thereof."



MOTOR CITY ELECTRIC TECHNOLOGIES INC.
 AUTOMATION AND CONTROLS SOLUTIONS
 9440 GRINNELL
 DETROIT, MI 48213-1151
 PHONE (313) 921-5300 FAX (313) 921-5310
 "AN EQUAL OPPORTUNITY EMPLOYER"

INVOICE

OMID
 ONE PUBLIC WORKS DRIVE, BUILDING 95
 WATERFORD, MI 48328-

Customer
 PO Number
 WO #00532

Job Number	Sub Job	Contract Number	Date Performed	Application	
				Date	Number
922567	0	001	2/1/2022	2/9/2022	94265

SID LOCKHART

Item No	Description of Work	Contract Amount	Previous Billings	Current Amount	To Date Complete & Stored	Balance To Finish	Current Retainage
001	NESP SCADA CUTOVER	\$54.00	-	\$54.00	\$54.00	-	-
Totals:		\$54.00		\$54.00	\$54.00		
Less Retained:				-			
Invoice Total:				\$54.00			

AS NEEDED ELECTRICAL AND ENGINEERING SERVICE

SEE ATTACHED INVOICE SUMMARY AND FIELD REPORT

82912 - 6010101 - 149090- 730660 - 5469 - Ch. 21 - v# 7755 - li# 41132 - exp. 12/31/23

WORK PERFORMED 2/1/2022

JL Brun

3/8/2022

TM 2-9-22

complete electrical construction

"We hereby certify that the articles and services covered by this invoice were produced and performed in compliance with all applicable requirements of Section 6, 7 and 12 of the Fair Labor Standards Act, as amended, and of regulations and orders of the United States Department of Labor issued under Section 14 thereof."



MOTOR CITY ELECTRIC TECHNOLOGIES INC.

AUTOMATION AND CONTROLS SOLUTIONS

9440 GRINNELL

DETROIT, MI 48213-1151

PHONE (313) 921-5300 FAX (313) 921-5310

"AN EQUAL OPPORTUNITY EMPLOYER"

INVOICE

OMID
ONE PUBLIC WORKS DRIVE, BUILDING 95
WATERFORD, MI 48328-

Customer
PO Number
WO #00533

Job Number	Sub Job	Contract Number	Date Performed	Application	
				Date	Number
922567	0	001	2/2/2022	2/9/2022	94266

SID LOCKHART

Item No	Description of Work	Contract Amount	Previous Billings	Current Amount	To Date Complete & Stored	Balance To Finish	Current Retainage
001	NESP SCADA CUTOVER	\$63.00	-	\$63.00	\$63.00	-	-
Totals:		\$63.00		\$63.00	\$63.00		
Less Retained:				-			
Invoice Total:				\$63.00			

AS NEEDED ELECTRICAL AND ENGINEERING SERVICE

SEE ATTACHED INVOICE SUMMARY AND FIELD REPORT

82912 - 6010101 - 149130- 730660 - 5469 - Ch. 21 - v# 7755 - li# 41132 - exp. 12/31/23

WORK PERFORMED 2/2/2022

JL Run

3/8/22

TM-2-9-22

complete electrical construction

"We hereby certify that the articles and services covered by this invoice were produced and performed in compliance with all applicable requirements of Section 6, 7 and 12 of the Fair Labor Standards Act, as amended, and of regulations and orders of the United States Department of Labor issued under Section 14 thereof."



MOTOR CITY ELECTRIC TECHNOLOGIES INC.
 AUTOMATION AND CONTROLS SOLUTIONS
 9440 GRINNELL
 DETROIT, MI 48213-1151
 PHONE (313) 921-5300 FAX (313) 921-5310
 "AN EQUAL OPPORTUNITY EMPLOYER"

INVOICE

OMID
 ONE PUBLIC WORKS DRIVE, BUILDING 95
 WATERFORD, MI 48328-

Customer
 PO Number
 WO #00539

Job Number	Sub Job	Contract Number	Date Performed	Application	
				Date	Number
922567	0	001	2/3/2022	2/9/2022	94267

SID LOCKHART

Item No	Description of Work	Contract Amount	Previous Billings	Current Amount	To Date Complete & Stored	Balance To Finish	Current Retainage
001	NESP SCADA CUTOVER	\$315.00	-	\$315.00	\$315.00	-	-
Totals:		\$315.00		\$315.00	\$315.00		
Less Retained:				-			
Invoice Total:				\$315.00			

AS NEEDED ELECTRICAL AND ENGINEERING SERVICE

SEE ATTACHED INVOICE SUMMARY AND FIELD REPORT

82912 - 6010101 - 149090- 730660 - 5469 - Ch. 21 - v# 7755 - li# 41132 - exp. 12/31/23

WORK PERFORMED 2/3/2022

3/8/22

TM-2/15-22 *JL* *Bra*

complete electrical construction

"We hereby certify that the articles and services covered by this invoice were produced and performed in compliance with all applicable requirements of Section 6, 7 and 12 of the Fair Labor Standards Act, as amended, and of regulations and orders of the United States Department of Labor issued under Section 14 thereof."



MOTOR CITY ELECTRIC TECHNOLOGIES INC.

AUTOMATION AND CONTROLS SOLUTIONS

9440 GRINNELL

DETROIT, MI 48213-1151

PHONE (313) 921-5300 FAX (313) 921-5310

"AN EQUAL OPPORTUNITY EMPLOYER"

INVOICE

OMID
ONE PUBLIC WORKS DRIVE, BUILDING 95
WATERFORD, MI 48328-

Customer
PO Number

Table with columns: Job Number, Sub Job, Contract Number, Date Performed, Application Date, Application Number. Values: 922567, 0, 001, 3/1/2022, 3/3/2022, 94319

SID LOCKHART

Main invoice table with columns: Item No, Description of Work, Contract Amount, Previous Billings, Current Amount, To Date Complete & Stored, Balance To Finish, Current Retainage. Includes item 001 NESP SCADA CUTOVER and a Totals row.

AS NEEDED ELECTRICAL AND ENGINEERING SERVICE

SEE ATTACHED INVOICE SUMMARY AND FIELD REPORT

WORK ORDER #00070 - WORK PERFORMED 3/1/2022

82912 - 6010101 - 149130 730660 - 5469 - Ch. 21 - v# 7755 - li# 41132 - exp. 12/31/23

Handwritten signatures and dates: JH Ben 3/8/22, TM 3-4-22

complete electrical construction

"We herby certify that the articles and services covered by this invoice were produced and performed in compliance with all applicable requirements of Section 6, 7 and 12 of the Fair Labor Standards Act, as amended, and of regulations and orders of the United States Department of Labor issued under Section 14 thereof."



MOTOR CITY ELECTRIC TECHNOLOGIES INC.

AUTOMATION AND CONTROLS SOLUTIONS

9440 GRINNELL

DETROIT, MI 48213-1151

PHONE (313) 921-5300 FAX (313) 921-5310

"AN EQUAL OPPORTUNITY EMPLOYER"

INVOICE

OMID
ONE PUBLIC WORKS DRIVE, BUILDING 95
WATERFORD, MI 48328-

Customer
PO Number

Table with columns: Job Number, Sub Job, Contract Number, Date Performed, Application Date, Application Number. Row 1: 922567, 0, 001, 2/24/2022, 3/3/2022, 94320

SID LOCKHART

Main invoice table with columns: Item No, Description of Work, Contract Amount, Previous Billings, Current Amount, To Date Complete & Stored, Balance To Finish, Current Retainage. Includes row for 001 NESP SCADA CUTOVER and a Totals row.

AS NEEDED ELECTRICAL AND ENGINEERING SERVICE

SEE ATTACHED INVOICE SUMMARY AND FIELD REPORT

82912 - 6010101 - 149090- 730660 - 5469 - Ch. 21 - v# 7755 - li# 41132
- exp. 12/31/23

WORK ORDER #00561 COMPLETED 2/24/2022

Handwritten signature: Jd Ben

3/8/22

Handwritten circled initials: TM

Handwritten date: 3-4-22

complete electrical construction

"We herby certify that the articles and services covered by this invoice were produced and performed in compliance with all applicable requirements of Section 6, 7 and 12 of the Fair Labor Standards Act, as amended, and of regulations and orders of the United States Department of Labor issued under Section 14 thereof."



NTH Consultants, Ltd.
Infrastructure Engineering
and Environmental Services

**82912- 6010101- 149662-730639- 2603 - Ch.21 - v# 4716 - li
#24138 - exp. 12/31/23**

Omi Drain Drainage District
One Public Works Drive
Building 95 West
Waterford, MI 48328

Invoice # : 2
Project : 61210495
Invoice Group :
Invoice Date : 3/1/2022

Attention: Sid Lockhart

For Professional Services Rendered from 1/22/2022 - 2/18/2022

Supplementary Support Services at the Northeast Sewage Pumping Station (NESPS)

Task 01	Health and Safety Audit	\$16,137.00
Task 02	CS-6 Emergency Bypass	\$39,643.00
Task 03	Wet Wall Screen Cleaning Equipment	\$17,069.00

Preliminary Budget Amount \$72,849.00
Percent Complete: 43.70%

Analysis of Costs		This Invoice	Cumulative
Direct Salaries		\$ 2,680.24	\$ 5,756.62
Overhead %	188.00	5,038.85	10,822.45
Total Regular Labor Expense		7,719.09	16,579.07
Total Direct Labor		7,719.09	7,719.09
Profit / Fixed Fee %	12.00	926.29	1,989.49
Direct Expenses Charge		31.43	158.41
Expense Multiplier %	5.00	1.57	7.93
Direct Subcontractor Charge		1,153.60	12,356.10
Subcontractor/Subconsultant Multiplier %	6.00	69.22	741.37
Total Other Direct Charges Reimbursables		1,255.82	13,263.81
Total Costs:		9,901.20	31,832.36
Total Due This Invoice		\$ 9,901.20	\$ 31,832.36



NTH Consultants, Ltd.
 Infrastructure Engineering
 and Environmental Services

**82912 - 6010101 - 149662 - 731458- 2603 - Ch. 21 -
 v#238 - li#24138 - exp. 12/31/23**

**OMI Drain Drainage District
 One Public Works Drive
 Building 95 West
 Waterford, MI 48328**

**Invoice # : 7
 Project : 61210124
 Invoice Group : **
 Invoice Date : 3/1/2022**

Attentior Sid Lockhart

For Professional Services Rendered from 1/22/2022 - 2/18/2022

Consulting Services Regarding 2021 OMID System Inspection

Task 01 Inspection and Reporting \$526,974.00
Preliminary Budget Amount \$526,974.00
Percent Complete: 47.61%

Analysis of Costs	This Invoice	Cumulative
Direct Salaries	\$ 721.23	\$ 14,199.96
Overhead %	188.00 1,355.91	26,695.92
Total Regular Labor Expense	2,077.14	40,895.88
Total Direct Labor	2,077.14	2,077.14
Profit / Fixed Fee %	12.00 249.26	4,907.50
Direct Expenses Charge	0.00	844.87
Expense Multiplier %	5.00 0.00	42.27
Direct Subcontractor Charge	4,714.10	192,642.16
Subcontractor/Subconsultant Multiplier %	6.00 282.85	11,558.54
Direct Unit Rate Charge	0.00	0.00
Total Other Direct Charges Reimbursables	4,996.95	205,087.84
Total Costs:	7,323.35	250,891.22
Total Due This Invoice	\$ 7,323.35	\$ 250,891.22

**84917 - 6010101 - 149015 - 731444 - 2603 - 1-3308-
ch 21 v#4716 - li#24138 - exp. 12/31/23**

**OMI Drain Drainage District
One Public Works Drive
Building 95 West
Waterford, MI 48328**

**Invoice # : 15
Project : 61-200186
Invoice Group : **
Invoice Date : 3/1/2022**

Attention Sid Lockhart

For Professional Services Rendered from 1/22/2022 - 2/18/2022

Provide Engineering Services for OMID NI-EA Contract No.1 PCI-4 Rehabilitation Project and CS-9 Gate Installation Project D-425

Task 01	NI-EA OMID Contract No. 1 CCA	\$2,258,051.29
Task 02	OMID CS-9 Gate CCA	\$217,468.00
	Preliminary Budget Amount	\$2,475,519.29
	Percent Complete:	43.90%

Analysis of Costs		This Invoice	Cumulative
Direct Salaries	\$	19,271.31	\$ 183,202.12
Overhead %	188.00	36,230.06	344,420.00
Total Regular Labor Expense		55,501.37	527,622.12
Total Direct Labor		55,501.37	527,622.12
Profit / Fixed Fee %	12.00	6,660.16	63,314.67
Direct Expenses Charge		1,492.47	5,698.71
Expense Multiplier %	5.00	74.62	284.93
Direct Subcontractor Charge		22,990.96	462,007.72
Subcontractor/Subconsultant Multiplier %	6.00	1,379.46	27,720.50
Direct Unit Rate Charge		0.00	0.00
Total Other Direct Charges Reimbursables		25,937.51	495,711.86
Total Costs:		88,099.04	1,086,648.65
Total Due This Invoice		\$ 88,099.04	\$ 1,086,648.64



**84917- 6010101 - 149015 - 731458 - 2603 - 1-3309- ch 21
- engcon v#4716 - li#24138 - exp. 12/31/23**

Omi Drain Drainage District
One Public Works Drive
Building 95 West
Waterford, MI 48328

Invoice # : 15
Project : 61-200280
Invoice Group : CMT
Invoice Date : 3/1/2022

Attentior Sid Lockhart

For Professional Services Rendered from **12/25/2021 - 2/18/2022**

Provide Engineering and Consulting Services regarding NESPS Pumping and Electrical System Upgrade (D-421)

Task 01	CMT Services	\$130,138.00
Task 02	Tnemecc Coating Observation	\$0.00
	Preliminary Budget Amount	\$130,138.00
	Percent Complete:	77.00%

Analysis of Costs	This Invoice	Cumulative
Direct Salaries	\$ 419.39	\$ 26,343.80
Overhead %	188.00 788.45	49,526.34
Total Regular Labor Expense	1,207.84	75,870.14
Total Direct Labor	1,207.84	75,870.14
Profit / Fixed Fee %	12.00 144.94	9,104.42
Direct Expenses Charge	691.43	14,494.00
Expense Multiplier %	5.00 34.57	724.71
Direct Subcontractor Charge	0.00	10.00
Subcontractor/Subconsultant Multiplier %	6.00 0.00	0.60
Direct Unit Rate Charge	0.00	0.00
Total Other Direct Charges Reimbursables	726.00	15,229.31
Total Costs:	2,078.78	100,203.87
Total Due This Invoice	\$ 2,078.78	\$ 100,203.87



84917 - 6010101 - 149015 - 730639 - 2603 - 1-3308 - Ch.21
v#4716 - li#24138 - exp. 12/31/23

OMI Drain Drainage District
One Public Works Drive
Building 95 West
Waterford, MI 48328

Invoice # : 33
Project : 61-190078
Invoice Group : NI-EA
Invoice Date : 3/1/2022

Attention: Sid Lockhart

For Professional Services Rendered from 1/22/2022 - 2/18/2022

Engineering Design Services for Rehabilitation of NI-EA Sections PCI-4

Task 01	Project Management	\$276,159.00
Task 02	Condition Assessment	\$241,609.00
Task 03	Subsurface Utility Engineering	\$65,579.00
Task 04	Basemap Survey	\$89,327.00
Task 05	Geotechnical Investigation	\$134,797.00
Task 05A	7-Mile Utility Exploration/Design	\$0.00
Task 05B	Additional Geotech for PCI-4 Shaft	\$0.00
Task 06	Environmental Study	\$60,642.00
Task 07	Basis of Design	\$379,785.00
Task 08	Rehabilitation Design	\$282,099.00
Task 09	Contract Drawings	\$235,070.00
Task 10	Contract Specifications	\$188,178.00
Task 11	Construction Costs	\$27,761.00
Task 12	Permits & Coordination	\$25,655.00
Task 13	Bidding Assistance	\$198,402.00
Task 14	Gate Automation	\$68,770.00

Preliminary Budget Amount \$2,273,833.00
Percent Complete: 92.90%

Analysis of Costs	This Invoice	Cumulative
Direct Salaries	\$ 2,811.79	\$ 305,914.55
Overhead %	188.00 5,286.17	575,119.37
Total Regular Labor Expense	8,097.96	881,033.92
Total Direct Labor	8,097.96	878,338.79
Profit / Fixed Fee %	12.00 971.75	105,724.05
Direct Expenses Charge	0.00	27,664.27
Expense Multiplier %	5.00 0.00	1,383.26
Direct Subcontractor Charge	7,100.94	1,034,575.03
Subcontractor/Subconsultant Multiplier %	6.00 426.05	62,074.65
Direct Unit Rate Charge	0	0
Total Other Direct Charges Reimbursables	7,526.99	1,125,697.21
Total Costs:	16,596.70	2,112,455.18
Total Due This Invoice	\$ 16,596.70	\$ 2,112,455.19



NTH Consultants, Ltd.
Infrastructure Engineering
and Environmental Services

**84915 - 149015 - 730639 - 2603 - 1-2232 Ch 21 - eng con v#4716
exp. 12/31/23 li#24138**

**OMI Drain Drainage District
One Public Works Drive
Building 95 West
Waterford, MI 48328**

**Invoice # : 62
Project : 61-210313
Invoice Group : **
Invoice Date : 3/1/2022**

Attentior Sid Lockhart

For Professional Services Rendered from 1/22/2022 - 2/18/2022

Consulting Services Regarding Additional OMID Rehabilitation Program 2021 Closeout Services and As-Needed NESPS Maintenance Tasks

Task 01	Contract 3 NESPS Rehab Closeout	\$9,563.00
Task 02	PCI-4 Liner Deterioration Closeout	\$10,939.00
Task 03	Discharge Pipe Coating Rehabilitation	\$27,930.00
Task 04	NESPS Wet Well Sediment Survey	\$19,639.00
	Preliminary Budget Amount	\$68,071.00
	Percent Complete:	50.35%

Analysis of Costs		This Invoice	Cumulative
Direct Salaries		\$ 1,036.81	\$ 6,108.95
Overhead %	188.00	1,949.20	11,484.83
Total Regular Labor Expense		2,986.01	17,593.78
Total Direct Labor		2,986.01	17,593.78
Profit / Fixed Fee %	12.00	358.32	2,111.25
Direct Expenses Charge		0.00	0.00
Expense Multiplier %	5.00	0.00	0.00
Direct Subcontractor Charge		2,963.47	13,872.15
Subcontractor/Subconsultant Multiplier %	5.00	148.17	693.61
Total Other Direct Charges Reimbursables		3,111.64	14,565.76
Total Costs:		6,455.98	34,270.79
Total Due This Invoice		\$ 6,455.97	\$ 34,270.78



Oakland County Water Resources Commissioner
Attn: Sid Lockhard, P.E.
One Public Works Drive
Building 95-West
Waterford 48328

February 8, 2022
Invoice No: 03559.01 - 20

**84917 - 6010101 - 149015 - 731458- 6096- 1-3308 - ch21 - engcon - v#16918 -
exp. 5/29/23**

Project 03559.01 Oakland-Macomb Interceptor Drainage 2020

JL *BR* 3/8/22

Professional Services from January 1, 2022 to January 31, 2022

Professional Personnel

	Hours	Rate	Amount	
Zann, John	61.00	94.00	5,734.00	
Totals	61.00		5,734.00	
Total Labor				5,734.00

Additional Fees

Overhead	149.10 % of 5,734.00		8,549.39	
Profit	10.00 % of 14,283.39		1,428.34	
Total Additional Fees			9,977.73	9,977.73

Billing Limits

	Current	Prior	To-Date
Total Billings	15,711.73	168,707.96	184,419.69
Limit			450,000.00
Remaining			265,580.31

Total this Invoice \$15,711.73

Please remit payment to PMA CONSULTANTS LLC, PO BOX 675234, DETROIT, MI 48267-5234. Please direct any questions regarding this invoice to Samantha Zeisler, Project Administrator, at 734-418-7897 or szeisler@pmaconsultants.com

Agenda Item No. 11

Other Business

Agenda Item No. 12

Adjourn