

## AGENDA

### Oakland-Macomb Interceptor Drain Drainage Board Macomb and Oakland Counties

**April 20, 2022 – 11:30 a.m.**

Office of the Oakland County Water Resources Commissioner  
One Public Works, Building 95 West  
Waterford, Michigan, and Microsoft Teams

1. Call meeting to order

Board Members:

Michael Gregg, Chair, Michigan Department of Agriculture and Rural Development  
Candice Miller, Macomb County Public Works Commissioner  
Jim Nash, Oakland County Water Resources Commissioner

2. Motion to approve the meeting agenda for April 20, 2022
3. Motion to approve the Drainage District Board Meeting Minutes from March 16, 2022
4. Public Comment
5. GLWA / Highland Park Litigation
6. Motion to approve the following Engineering Work Orders:
  - a) NTH for Control Structure Investigation to increase contract #2603 by a not-to-exceed amount of \$10,022
  - b) ASI for NESPS Pumping and Electrical Upgrades for Additional METCO Services to increase contract #5470 by a not-to-exceed amount of \$284,079.60
7. Motion to approve the following Change Orders:
  - a) Walsh Construction Change Order No. 21 for the NESPS Pump & Electrical Upgrades Project for a net increase in the amount of \$43,122.99
8. Motion to approve the following Construction Estimates:
  - a) Construction Estimate No.18 for Walsh Construction for NESPS Pump & Electrical Upgrades Project (GMP Phase) in the amount of \$1,546,006.57 with a transfer to the Oakland County Treasurer in the amount of \$171,778.52
  - b) Construction Estimate No.13 for Marra Services for NI-EA Contract No. One for PCI 4 Rehabilitation in the amount of \$797,643.56 with a transfer to the Oakland County Treasurer in the amount of \$53,608.82
  - c) Final Construction Estimate No. 41 for Inland Waters Pollution Control, Inc. for OMID Segment 2, Contract 3 in the amount of \$907.96

- d) Final Construction Estimate No. 20 for Inland Waters Pollution Control Inc. for OMID Segment 2, Contract 3 – Emergency Gatehouse Repairs in the amount of \$6,718.58

9. Report/Update – Status of OMID Repairs Project

10. Financial Reports – General Financial Report and Status of State Revolving Fund Financing and Other Financing

11. Motion to approve the following invoices:

a) Reimbursement of Oakland County WRC-Incurred Expenses and Costs

1) Labor/Fringes/Non-Direct Labor Factor

- Segment 5 NI-EA Construction \$ 2,861.8
- Segment 5 NESPS Mech./Elect. Construction \$ 18,374.25

2) Equipment Charges

- Segment 5 NI-EA Construction \$ 144.58
- Segment 5 NESPS Mech./Elect. Construction \$ 1,769.90

b) ASI

Invoice No. 38 NESPS \$ 82,095.87

c) CH2M

Invoice No. 38 O&M \$ 3,842.51

d) Clark Hill

- 1) Invoice No. 1185359 NI-EA \$ 994.50
- 2) Invoice No. 1185477 NI-EA \$ 2,430.00
- 3) Invoice No. 1185478 O&M \$ 270.00
- 4) Invoice No. 1070310 NI-EA \$ 1,944.00
- 5) Invoice No. 1091359 NI-EA \$ 2,079.00
- 6) Invoice No. 1119387 NI-EA \$ 2,484.00

e) D'Angelo Brothers

Invoice No. 8123-OMID O&M \$ 13,115.00

f) Dickinson Wright

Invoice No. 1671430 O&M \$ 118.50

g) Hesco

- 1) Invoice No. 2213496 O&M \$ 2,742.25
- 2) Invoice No. 2213521 O&M \$ 430.00

h) Meadowbrook Insurance

Invoice No. 84958 NESPS \$ 47,950.43

i) Metco

- 1) Invoice No. 1811-39 O&M \$ 78,919.98

j) Motor City Electric Company

- 1) Invoice No. 36819 NI-EA \$ 10,200.00
- 2) Invoice No. 93699 O&M \$ 315.00
- 3) Invoice No. 93730 O&M \$ 154.00
- 4) Invoice No. 93731 O&M \$ 216.00
- 5) Invoice No. 93732 O&M \$ 3,096.00
- 6) Invoice No. 93733 O&M \$ 180.00
- 7) Invoice No. 93767 O&M \$ 495.00
- 8) Invoice No. 93768 O&M \$ 4,620.00
- 9) Invoice No. 93770 O&M \$ 90.00
- 10) Invoice No. 93799 O&M \$ 180.00

11)	Invoice No. 93803	O&M	\$	90.00
12)	Invoice No. 94071	O&M	\$	846.00
13)	Invoice No. 94072	O&M	\$	315.00
14)	Invoice No. 94073	O&M	\$	180.00
15)	Invoice No. 94153	O&M	\$	180.00
16)	Invoice No. 94244	O&M	\$	90.00
17)	Invoice No. 94245	O&M	\$	45.00
18)	Invoice No. 94321	O&M	\$	90.00
19)	Invoice No. 94388	O&M	\$	180.00
20)	Invoice No. 94389	O&M	\$	810.90
k) NTH Consultants, Ltd				
1)	Supplementary Support Services at NESPS Invoice No. 3	O&M	\$	9,794.91
2)	Consulting Services for System Inspect. Invoice No. 8	O&M	\$	3,806.31
3)	Contract No. 1 PCI-4 Invoice No. 16	NI-EA	\$	128,408.46
4)	NI-EA – Engineering Design Services Rehabilitation of NI-EA Sections PCI-4 Invoice No. 34	NI-EA	\$	12,079.69
5)	Eng./Consult. Services NESPS CMT Invoice No. 16	NESPS	\$	2,698.70
6)	Rehabilitation Program 2021 Closeout Services Invoice No. 63	O&M	\$	5,053.64
l) PM Technologies				
1)	Invoice No. 155094	O&M	\$	643.45
2)	Invoice No. 155221	O&M	\$	817.50
3)	Invoice No. 157506	O&M	\$	1,000.00
m) PMA Consultants				
1)	Invoice No. 03559.01-21	NI-EA	\$	16,484.45
2)	Invoice No. 03559.01-22	NI-EA	\$	12,363.33
n) Rotor Electric Company				
1)	Invoice No. 12489	O&M	\$	5,325.98
2)	Invoice No. 12490	O&M	\$	3,067.30
3)	Invoice No. 12491	O&M	\$	2,775.00
4)	Invoice No. 12492	O&M	\$	15,201.05
5)	Invoice No. 12493	O&M	\$	994.00
6)	Invoice No. 12494	O&M	\$	994.00
7)	Invoice No. 12495	O&M	\$	4,314.98
8)	Invoice No. 12496	O&M	\$	4,628.11
9)	Invoice No. 12497	O&M	\$	10,155.01

12. Other Business

13. Adjourn

Next Regular Meeting: May 18, 2022 11:30 a.m., Eastern Standard Time.

**Agenda Item No. 3**

Board Meeting Minutes from March 16, 2022

**MINUTES OF THE REGULAR MEETING OF THE DRAINAGE BOARD  
FOR THE OAKLAND-MACOMB INTERCEPTOR DRAIN DRAINAGE DISTRICT**

March 16, 2022

Minutes of the regular meeting of the Drainage Board of the Oakland-Macomb Interceptor Drain Drainage District held at the office of the Oakland County Water Resources Commissioner, One Public Works Drive, Building 95 West, Waterford, Michigan on the 16<sup>th</sup> day of March at 11:30 a.m. Eastern Standard Time and via Microsoft Teams.

**PRESENT:**

Michael Gregg, Chairperson and Deputy for Gary McDowell, Director of the Michigan Department of Agriculture and Rural Development; Brian Baker for Candice Miller, Member and Macomb County Public Works Commissioner; and Jim Nash, Secretary and Oakland County Water Resources Commissioner.

**OTHERS PRESENT:**

Representing the office of the Macomb County Public Works Commissioner: Stephen Downing and Norb Franz. Representing the office of the Oakland County Water Resources Commissioner: Anne Vaara, Steve Korth, Brian Coburn, Sid Lockhart, Joel Brown, Evans Bantios, Raphael Chirolla, Megan Koss, and Stephanie Lajdziak. Others in attendance: Brady Harrington, MDARD; John Michalski, ASI; Fritz Klingler, FK Engineering; Larry Gilbert, Saju Sachidanandan, and Michelle Kitzinger, NTH Consultants; Jeff Ragle and Shawn Phelps, OC Fiscal Services; Terry Moore, Metco; Dave Pauline, Walsh Construction; Bruce Mann

1. Call meeting to order.

Chairperson Gregg called the meeting to order at 11:30 a.m.

2. Agenda.

Motion by Baker, supported by Nash, to approve the March 16, 2022 agenda as presented.

ADOPTED: Yeas - 3  
              Nays - 0

3. Minutes.

Motion by Nash, supported by Baker, to approve the minutes of the February 16, 2022 meeting.

ADOPTED: Yeas - 3  
              Nays - 0

4. Public Comment.

None.

5. Memorandum regarding operating budget, cost allocation and Capital Improvement Program for the upcoming rate year.

Raphael Chirolla presented a Memorandum requesting the Board approve the proposed operating budget, cost allocation and Capital Improvement Program for the rate year beginning July 1, 2022. He provided an overview of the budget, flow split, and capital projects planned for 2022. Mr. Chirolla also discussed the change in GLWA's rates. Motion by Nash, supported by Baker, to approve the proposed budget, cost allocation and Capital Improvement Program for the rate year beginning July 1, 2022 as presented.

ADOPTED: Yeas - 3  
Nays - 0

6. Change Order.

The following Change Orders were submitted to the Board for approval:

- a) Walsh Construction Change Order No. 20 for the NESPS Pump & Electrical Upgrades Project for a net increase in the amount of \$215,255.18. Motion by Nash, supported by Baker, to approve the Change Order as presented.

ADOPTED: Yeas - 3  
Nays - 0

- b) Marra Services Change Order No. 2 for the NI-EA OMID Contract 1 PCI-4 Rehabilitation Project for a net increase in the amount of \$143,806.88. Motion by Backer, supported by Nash, to approve the Change Order as presented.

ADOPTED: Yeas - 3  
Nays - 0

7. Construction Pay Estimates.

The following Construction Pay Estimates were submitted to the Board for approval:

- a) Construction Estimate No. 17 for Walsh Construction for NESPS Pump & Electrical Upgrades Project (GMP Phase) in the amount of \$24,647.47 with a partial retainage overpayment to the contractor in the amount of \$63,886.32. Motion by Nash, supported by Baker, to approve the Construction Pay Estimate as presented.

ADOPTED: Yeas - 3  
Nays - 0

- b) Construction Estimate No. 12 for Walsh Construction for CS-9 Gate Installation with a reserve payment to the contractor in the amount of \$48,629.00. Motion by Baker, supported by Nash, to approve the Construction Pay Estimate as presented.

ADOPTED: Yeas - 3  
Nays - 0

- c) Construction Estimate No. 12 for Marra Services for NI-EA Contract No. One for PCI 4 Rehabilitation in the amount of \$175,867.60 with a transfer to the Oakland

County Treasurer in the amount of \$19,543.85. Motion by Nash, supported by Baker, to approve the Construction Pay Estimate as presented.

ADOPTED: Yeas - 3  
 Nays - 0

8. Report/Update – Status of OMI Project, Segments 1 through 4, NESPS and NI-EA.

Fritz Klingler of FK Engineering presented the Project Progress Update to the Board and summarized the status of various projects. Motion by Nash, supported by Baker, to receive and file the report and summary.

ADOPTED: Yeas - 3  
 Nays - 0

9. Financial Reports.

Shawn Phelps of OC Fiscal Services presented the financial reports for Segments 1 through 5 and the NESPS. Motion by Baker, supported by Nash, to receive and file the financial reports.

ADOPTED: Yeas - 3  
 Nays - 0

10. Invoices.

The following invoices were submitted to the Board for approval:

- a) Reimbursement of Oakland County WRC-Incurred Expenses and Costs
  - 1) Labor/Fringes/Non-Direct Labor Factor
    - Segment 5 NI-EA Construction \$ 3,894.57
    - Segment 5 NESPS Mech./Elect. Construction \$ 18,111.49
  - 2) Equipment Charges
    - Segment 5 NI-EA Construction \$ 158.01
    - Segment 5 NESPS Mech./Elect. Construction \$ 1,709.78
- b) ASI, Inc.
  - 1) Invoice No. 37 NESPS \$ 72,559.95
- c) Clark Hill
  - 1) Invoice No. 1174160 NI-EA \$ 5,913.00
  - 2) Invoice No. 1174161 O&M \$ 4,698.00
- d) CH2M
  - Invoice No. 37 O&M \$ 4,409.10
- e) CSM Mechanical
  - 1) Invoice No. 21OMIDD002 O&M \$ 3,480.55
  - 2) Invoice No. 21OMIDD007 O&M \$ 562.50
  - 3) Invoice No. 21OMIDD009 O&M \$ 4,961.00
  - 4) Invoice No. 21OMIDD011 O&M \$ 3,099.26
  - 5) Invoice No. 21OMIDD013 O&M \$ 360.00
  - 6) Invoice No. 22OMIDD-003 O&M \$ 645.00
- f) Hesco
  - 1) Invoice No. 2213446 O&M \$ 6,724.75
  - 2) Invoice No. 2213447 O&M \$ 1,202.50

	3)	Invoice No. 2213456	O&M	\$	4,579.75
	4)	Invoice No. 20212685	O&M	\$	4,543.75
g)		Metco			
	1)	Invoice No. 1811-38	O&M	\$	70,448.33
	2)	Invoice No. 1811-37	O&M	\$	84,877.13
h)		Motor City Electric Company			
	1)	Invoice No. 94246	O&M	\$	189.00
	2)	Invoice No. 94247	O&M	\$	180.00
	3)	Invoice No. 94264	O&M	\$	725.64
	4)	Invoice No. 94265	O&M	\$	54.00
	5)	Invoice No. 94266	O&M	\$	63.00
	6)	Invoice No. 94267	O&M	\$	315.00
	7)	Invoice No. 94319	O&M	\$	716.64
	8)	Invoice No. 94320	O&M	\$	135.00
i)		NTH Consultants, Ltd			
	1)	Supplementary Support Services at NESPS Invoice No. 2	O&M	\$	9,901.20
	2)	Consulting Services for System Inspect. Invoice No. 7	O&M	\$	7,323.35
	3)	Contract No. 1 PCI-4 Invoice No. 15	NI-EA	\$	88,099.04
	4)	NI-EA – Engineering Design Services Rehabilitation of NI-EA Sections PCI-4 Invoice No. 33	NI-EA	\$	16,596.70
	5)	Eng./Consult Services NESPS CMT Invoice No. 15	NESPS	\$	2,078.78
	6)	Rehabilitation Program 2021 Closeout Services Invoice No. 62	O&M	\$	6,455.97
j)		PMA Consultants			
	1)	Invoice No. 03559.01-20	NESPS	\$	15,711.73

Motion by Baker, supported by Nash to approve the invoices as presented.

ADOPTED: Yeas - 3  
Nays - 0

11. Other Business.

12. Adjourn.

Motion by Nash, supported by Baker, to adjourn the February 16, 2022, meeting at 12:49 p.m.

ADOPTED: Yeas - 3  
Nays - 0

Next Regular Meeting: April 20, 2022 at the *Office of the Oakland County Water Resources Commissioner, One Public Works, Building 95 West, Waterford, Michigan* and electronically at 11:30 a.m., Eastern Standard Time.



I hereby certify that the foregoing constitutes the minutes of the Drainage Board for the Oakland-Macomb Interceptor Drain Drainage District, at a meeting held on March 16, 2022 and that the meeting was conducted and public notice was given in compliance with the Open Meetings Act being Act 267, Public Acts of Michigan, 1976, as amended, and that the minutes were kept and will be or have been made available to the public as required by the Act.

IN WITNESS WHEREOF, I have hereunto affixed my official signature on this 16<sup>th</sup> day of March 2022.

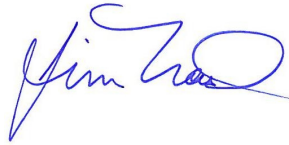

---

Jim Nash, Secretary  
Oakland-Macomb Interceptor Drain Drainage Board

**Agenda Item No. 4**

Public Comment

**Agenda Item No. 5**

**GLWA / Highland Park Litigation**



**Mark A. Hackel**

County Executive

**Candice S. Miller**

Public Works Commissioner

March 29, 2022

Macomb County Leaders,

For the past ten years, the City of Highland Park has made only partial payments to the Great Lakes Water Authority (GLWA) for wholesale water and sewer charges. Last year they stopped making any payments. GLWA has passed this bad debt expense on to suburban member communities per past rate settlement agreements. Highland Park arrearages charged by GLWA to other communities cumulatively totals \$62.9 million through FY 2023, with Macomb's share at \$13.5 million.

Despite years of litigation, endless Highland Park appeals, and our past efforts to encourage the State to help mediate the issues and assist Highland Park, the unpaid balance only grows. It is unfair that others are forced to pay another community's unpaid charges. It is also unfortunate that Highland Park officials have put their community's residents in a position that a judgment against the City would likely force them into bankruptcy.

The State has some responsibility in this matter as the State requested temporary emergency water service for Highland Park ten years ago. Yet today the service continues without any payments. The State should have resolved these issues when it formed the GLWA and when it appointed and subsequently discontinued emergency management oversight of Highland Park.

Many of you have sent letters to the Governor's office and discussed this topic in your communities. The two of us have discussed a plan to best highlight our collective concerns and encourage and direct the State to help resolve these long-term issues:

- We plan to intervene in the ongoing litigation with the goal for the Court to persuade the State to enter mediation and find a long-term solution for all parties.
- Several Macomb communities are considering withholding payment to the GLWA for the additional Highland Park charges included in the FY 2023 charges effective July 1, 2022 totaling \$1.6 million. Currently, we are not seeking the return of the remaining \$11.9 million already paid by Macomb communities over the past 10 years.
- The withheld amounts will be held in escrow by the communities until the State comes to the table and the matter is resolved.
- We plan to hold a press conference tomorrow, Wednesday, March 30 at 11:00 AM in the lobby of the County Administration Building to highlight the issues and to request the State's immediate involvement. We encourage you to join us for that media briefing.

While it is unlikely that we will be able to recover the entire amounts paid, we need to reach a long-term solution for all parties.

We look forward to your participation in tomorrow's event. In the meantime, if you have any questions please feel free to contact us at any time.

Sincerely,



Mark A. Hackel  
Macomb County Executive



Candice S. Miller  
Macomb County Public Works Commissioner

Attachment

**Highland Park Unpaid Bills  
Charged to Macomb Communities  
Effective July 1, 2022 (FY 2023)**

<b>Community</b>	<b>Water</b>	<b>Sewer</b>	<b>Total</b>
Bruce Township	\$1,200		\$1,200
Center Line	1,700	20,900	22,600
Chesterfield Township	15,300	70,100	85,400
Clinton Township	26,800	200,370	227,170
Eastpointe	5,500	116,610	122,110
Fraser	4,300	39,360	43,660
Harrison Township	5,800	59,940	65,740
Lenox Township	1,000	10,560	11,560
Macomb Township	44,700	132,820	177,520
New Haven Village	1,300	7,800	9,100
Romeo	900		900
Roseville	9,500	126,520	136,020
Shelby Township	51,100	92,490	143,590
St. Clair Shores	11,000	153,730	164,730
Sterling Heights	54,800	289,810	344,610
Utica	2,000	15,270	17,270
Warren	36,500		36,500
Washington Township	8,300	26,070	34,370
<b>TOTAL</b>	<b>\$281,700</b>	<b>\$1,362,350</b>	<b>\$1,644,050</b>

**Total Highland Park Unpaid Bills  
Charged to Macomb Communities  
Through FY 2023 (10 years)**

<b>Community</b>	<b>Water</b>	<b>Sewer</b>	<b>Total</b>
Bruce Township	\$11,000		\$11,000
Center Line	16,600	174,500	191,100
Chesterfield Township	150,900	506,100	657,000
Clinton Township	271,400	1,471,800	1,743,200
Eastpointe	54,600	1,073,800	1,128,400
Fraser	43,100	285,200	328,300
Harrison Township	56,700	442,800	499,500
Lenox Township	9,900	73,400	83,300
Macomb Township	443,600	960,300	1,403,900
New Haven Village	13,400	57,000	70,400
Romeo	9,000		9,000
Roseville	94,400	1,165,000	1,259,400
Shelby Township	508,300	674,000	1,182,300
St. Clair Shores	108,600	1,415,600	1,524,200
Sterling Heights	544,300	2,122,900	2,667,200
Utica	20,000	112,100	132,100
Warren	365,300		365,300
Washington Township	82,200	189,300	271,500
<b>TOTAL</b>	<b>\$2,803,300</b>	<b>\$10,723,800</b>	<b>\$13,527,100</b>

# GLWA faces mutiny in western Wayne County over disputed Highland Park debt

**James David Dickson**  
The Detroit News

*Highland Park* — Eighteen communities in western Wayne County have declared they intend to withhold a portion of their water and sewer bills tied to \$54 million in disputed Highland Park debt, a development one expert said could hurt the Great Lakes Water Authority with lenders.

A conference representing the western Wayne communities voted in favor of a resolution on March 11 to withhold the money after the Great Lake Water Authority earlier in the month sent letters to the leaders of its 87 other customer communities, who are being asked to pick up the arrearage. Almost half of the GLWA's 2.4% sewage rate hike is tied to Highland Park's unpaid bills and is being passed on to the authority's remaining member communities when it goes into effect July 1.

Highland Park said it does not owe any money and is due \$1 million, citing a 2021 Wayne County Circuit Court ruling. The Great Lakes Water Authority late last year sued Highland Park in the Michigan Court of Claims over the funds, but the case has been paused.

The 18-community Conference of Western Wayne has contributed about \$15 million to the bad debt, or 27%, an amount that is expected to grow to \$16.4 million by July 2023, according to the conference's resolution. The communities are shouldering almost three-quarters of Wayne County's \$19.9 million contribution to paying off Highland Park's unpaid bills.

The conference hopes each community's government will back the resolution and hold back the debt payments, said Jordyn Sellek, executive director of the Conference of Western Wayne.

The Plymouth Township Board of Trustees voted last week to withhold and place in escrow the portion of its GLWA bill related to Highland Park's debt until the matter is resolved, Plymouth Township Supervisor Kurt Heise said.

"I'm not happy with the fact that the communities have been kept in the dark on this, possibly going back 10 years now," Heise said. "That's not acceptable. That's not transparent at all."

The western Wayne funds, if all withheld and placed in escrow, would account for about 1.1% of the authority's system wide water and sewer charges, GLWA interim Chief Executive Officer Suzanne Coffey said in a statement. The fiscal year doesn't begin for three months or until July 1, she said.

The regional water authority sent the letter asking communities to push the state government to resolve the Highland Park matter. The Conference of Western Wayne's response was unique.



The South Oakland County Water Authority sent a March 11 letter to Gov. Gretchen Whitmer that was more in line with what GLWA sought from its member communities. The South Oakland authority argued that "the state of Michigan is completely responsible for creating this situation" and should "immediately reimburse" GLWA to resolve it.

The Great Lakes authority's leader downplayed the difference between the two approaches, saying both approaches ultimately seek a resolution.

"Our understanding of the goal of the Conference of Western Wayne is to drive engagement by the state, with other responsible parties, to the table in order to resolve this matter that continues to impact the region," Coffey said. "Accordingly, the focus is on resolving the matter this year so that it is not an issue in future years."

But the potential mutiny could affect the Detroit regional water authority's perception with lenders, said Greg Miller, chair of the accounting program at the University of Michigan's Ross School of Business.

"If you were going to lend them money, and you say, 'Well, when these big things happen, their customer base doesn't pay for it,' the people who lend money take that into account," Miller said.

"That money's gone. A customer didn't pay for it," he said. "And so now the question is, who bears the cost?"

"That's the kind of thing credit rating agencies would be concerned with," Miller said. When a credit rating agency downgrades a government or authority's credit rating, it increases the cost to borrow money.

## **How mutiny began**

Highland Park's debt issue might have gone unnoticed if the water authority hadn't sent the letter, community leaders said.

As the Great Lakes Water Authority briefing to the western Wayne leaders explained, "If one community does not pay for their allocated cost of service, this creates a bad debt. The bad debt expense is then allocated to the other communities in future years."

***The GLWA letter argued communities should urge Whitmer, a Democrat, to bring the parties to the table and resolve the debt. The letter was the idea of Brian Baker, who represents Macomb County on the GLWA board and chairs its finance committee.***

***"It was Macomb's idea to let the communities know the dollar amount for each community," Baker said. "And for a letter to be prepared, that the communities could send to the state, asking for the state's involvement in helping resolve this issue."***

The letter listed each of the community's payments so far for Highland Park's debt.

Dearborn tops the list, paying \$3.6 million, followed by Livonia's \$378,400, Canton Township's \$330,000 and Westland's \$197,700. Western Wayne's smaller communities are paying anywhere from Belleville's \$10,200 to Plymouth's \$34,700 to Garden City's \$53,600.

At least 14 communities use the Wayne County Rouge Valley system, one of the sewer operators in the region that has paid \$8.9 million so far toward Highland Park's unpaid bills, according to the GLWA letter.

The letter-listed amounts so far by community:

- Belleville: \$10,200
- Canton Township: \$330,000
- Dearborn: \$3,640,900
- Dearborn Heights: \$116,900
- Garden City: \$53,600
- Huron Township: \$47,500
- Inkster: \$42,700
- Livonia: \$378,400
- Northville: \$25,200
- Northville Township: \$180,900
- Plymouth: \$34,700
- Plymouth Township: \$143,200
- Redford Township: \$132,500

- Romulus: \$134,300
- Sumpter Township: \$21,500
- Van Buren Township: \$110,600
- City of Wayne: \$99,900
- Westland: \$197,700

The letter prompted the Conference of Western Wayne, "the governing voice of 700,000 residents," to study the issue further.

"The communities had no idea that they were even paying towards this until we got these letters," the conference's Sellek said. "And then we started doing some digging and found out more of the background and how much we had already paid."

## **State 'encourages' resolution**

Although the state of Michigan required Highland Park to start using Detroit water in November 2012, after years of issues with cloudy water from Highland Park's own water plant, it has been reluctant to force a resolution to the debt issue, even while acknowledging one is needed.

The Highland Park debt was a sticking point in the formation of the Great Lakes Water Authority, which began operation in 2016.

In May 2015, when Highland Park's unpaid bills were about half what they are now at \$26.5 million, Republican Gov. Rick Snyder told reporters at the Mackinac Policy Conference that "there will be some

good, healthy discussions to come up with a resolution in a week or two."

But no resolution ever came.

Oakland County Water Commissioner Jim Nash said: "We can't keep going like this."

"We really need the state to step in," Nash said. "It's something that we just need to take care of, and they're (Highland Park) not in any more of a position to do it than we are. The state ordered it. We need to have the state respond to this, in my mind."

But a March 2 letter from Michigan's Department of the Treasury to Highland Park Mayor Hubert Yopp the GLWA's Coffey reminded both parties that the issue is subject to litigation.

"This issue and other associated issues remain the subject of ongoing litigation between GLWA and Highland Park, including litigation in which GLWA has named the State of Michigan as a defendant," wrote Larry Steckelberg of the Department of Treasury's Community Services Division.

Steckelberg offered encouragement but no solution: "In light of the pending litigation between GLWA and Highland Park, and for the mutual benefit of both parties, the State of Michigan encourages GLWA and Highland Park to work collaboratively towards a mutually agreeable resolution to these complex disputes."

Whitmer's office sounded a similar note. Spokesman Bobby Leddy said in a statement that "it's important that the parties involved work together to find a resolution to this situation as quickly as possible."

## **Highland Park wants independence**

Highland Park has asked for state action of its own.

In a 5-0 vote at its March 21 meeting, Highland Park City Council passed a resolution "requesting state regulation and oversight" of the Great Lakes Water Authority.

City Administrator Cathy Square said there is no debt, except the \$1 million it was granted from the city of Detroit in a 2020 mediation. Detroit has not paid that judgment, Square said.



April 13, 2022

Re: Highland Park's Water and Sewer Debt

Dear Customer Communities:

I have talked with many of the leaders and stakeholders from the customer communities I represent and above all, they want to know two things when it comes to discussions about the water and sewer debt Highland Park owes to the Great Lakes Water Authority (GLWA). First, they want to know how much of that debt will be assessed against their municipality to make up for the shortfall. Second, they want to know my position on this obviously complex issue. With this letter, I intend to answer both questions.

It has been reported that municipalities in Wayne and Macomb counties have begun withholding a portion of their GLWA water bills related to the Highland Park matter. Instead, they are putting money in an escrow account pending a resolution of the contentious litigation between the regional water authority and Highland Park. I do not support that approach. I believe that path won't be particularly effective because costs are passed on during the rate-setting process. As I was quoted recently in The Detroit News, it's not like we can take the water back from Highland Park. It just means there's less money to spend on operations and maintenance and capital projects.

The attached tables provide a breakdown of the percentages each municipality pays in relationship to their share in the Clinton-Oakland Sewage Disposal System, the Evergreen-Farmington Sanitary Drain Drainage District, and the George W. Kuhn Drain Drainage District.

If you have any questions regarding this important matter, please feel free to contact me.

Sincerely,

A handwritten signature in blue ink that reads "Jim Nash".

Jim Nash





April 20, 2022

The Honorable Gretchen Whitmer, Governor  
P.O. Box 30013  
Lansing, Michigan 48909

**Re: Oakland-Macomb Interceptor Drain Drainage District  
Objection to Subsidizing Highland Park's Sewer Services**

Dear Governor Whitmer:

It's been nearly a year since the City of Highland Park has made any payments for the sewer services it receives from the Great Lakes Water Authority (GLWA). When Highland Park doesn't pay, its obligations are borne by the other communities receiving GLWA's sewer services. The Oakland-Macomb Interceptor Drain Drainage District is among those "other communities."

The State of Michigan has had a direct role in the City of Detroit, now GLWA, providing water services to Highland Park. By way of background, the state requested the Detroit Water & Sewerage Department provide emergency water services to Highland Park because the state determined the city's water treatment plant was creating a public health risk to its residents. On November 12, 2012, the state represented the repairs to the water treatment plant were to be completed within three or four days. Neither the state nor the city repaired the water treatment plant, and it remains shuttered to this date.

Today, Highland Park's payment history for both its water and sewer service from GLWA remains more than a little troubling. From 2013 through March of 2021, Highland Park has paid approximately half of what it owes for the sewer services it receives. If this trend of non-payment continues, by the end of FY 2023, this arrearage will top \$48 million.

To make up for this deficiency, GLWA has allocated more than \$10 million of Highland Park's current arrearages to the Oakland-Macomb Interceptor Drain Drainage District. For FY 2023 charges, the district is expected to pay an additional \$1.4 million of Highland Park's bill.

This inequity cannot continue. It is patently unfair for the people living in the Oakland-Macomb Interceptor District to be asked to pick up Highland Park's sewer tab. That's why, as secretary for the district, I'm asking that you intervene on behalf of the drainage district to resolve this matter. I'm confident that your staff and Suzanne Coffey, GLWA's Interim Chief Executive Officer, can find an equitable solution to this ongoing dilemma.

Sincerely,

A handwritten signature in blue ink that reads "Jim Nash".

Jim Nash, Secretary  
Oakland-Macomb Interceptor Drain Drainage District





**TABLE 1. Clinton Oakland Sewage Disposal System**

	<i>2023 Flow Allocation %</i>	<i>Total Highland Park Bad Debt Estimate</i>	<i>Portion of 2023 Sewer Charges for Highland Park Bad Debt</i>	<i>New Total Highland Park Bad Debt Estimate</i>
<i>OMIDDD</i>		\$10,103,300	\$1,388,100	
<i>COSDS</i>	31.951%	\$3,228,000	\$444,000	\$3,672,000
<i>Estimated Amount Per Customer</i>				
<i>Auburn Hills</i>	11.512%	\$372,000	\$51,000	\$423,000
<i>Independence Twp</i>	8.655%	\$279,000	\$38,000	\$317,000
<i>Lake Orion</i>	1.220%	\$39,000	\$5,000	\$44,000
<i>Oakland Twp</i>	2.818%	\$91,000	\$13,000	\$104,000
<i>Orion Twp</i>	9.862%	\$318,000	\$44,000	\$362,000
<i>Oxford</i>	1.287%	\$42,000	\$6,000	\$48,000
<i>Oxford Twp</i>	4.069%	\$131,000	\$18,000	\$149,000
<i>Rochester</i>	5.518%	\$178,000	\$24,000	\$202,000
<i>Rochester Hills</i>	23.486%	\$758,000	\$104,000	\$862,000
<i>Waterford Twp</i>	24.779%	\$800,000	\$110,000	\$910,000
<i>West Bloomfield Twp</i>	6.794%	\$219,000	\$30,000	\$249,000
<i>Total</i>	100.000%	\$3,227,000	\$443,000	\$3,670,000

Notes:

- The purpose of this table is to provide a general estimate of the total paid by each WRC customer community toward the Highland Park Bad Debt based on the current share allocations. It does not reflect the actual amount paid by each individual customer as the shares and amounts paid have changed each year. The estimate is being provided in response to requests from the customer communities to better understand the magnitude of the amount.
- The estimated amount per customer was determined as follows:

$$\begin{aligned}
 & \text{OMID HP Bad Debt from GLWA} \times \\
 & \text{COSDS \% Share of OMID for 2023} \times \\
 & \text{Community \% share of COSDS for 2023} \\
 & = \text{Estimated Amount per Customer}
 \end{aligned}$$

- Upon repayment of the Highland Park Debt, the funds are expected to be retained by GLWA to offset increasing operation and capital cost. Customers should not expect a refund check in the future.

**TABLE 2. Evergreen-Farmington Sanitary Drain Drainage District**

	2023 Flow Allocation %	Total Highland Park Bad Debt Estimate	Portion of 2023 Sewer Charges for Highland Park Bad Debt	New Total Highland Park Bad Debt Estimate
	<i>Estimated Amount Per Customer</i>			
Auburn Hills	0.757%	\$41,000	\$6,000	\$47,000
Beverly Hills	4.435%	\$240,000	\$32,000	\$272,000
Bingham Farms	0.574%	\$31,000	\$4,000	\$35,000
Birmingham	7.360%	\$398,000	\$53,000	\$451,000
Bloomfield Hills	2.436%	\$132,000	\$18,000	\$150,000
Bloomfield Township	17.345%	\$939,000	\$126,000	\$1,065,000
Franklin	0.518%	\$28,000	\$4,000	\$32,000
Lathrup Village	2.072%	\$112,000	\$15,000	\$127,000
Southfield	18.936%	\$1,025,000	\$138,000	\$1,163,000
Troy	4.207%	\$228,000	\$31,000	\$259,000
Farmington	0.780%	\$42,000	\$6,000	\$48,000
Farmington Hills	23.447%	\$1,269,000	\$170,000	\$1,439,000
Keego Harbor	0.834%	\$45,000	\$6,000	\$51,000
Orchard Lake Village	0.896%	\$49,000	\$7,000	\$56,000
West Bloomfield Township	12.620%	\$683,000	\$92,000	\$775,000
Acacia Park RTB	0.825%	\$45,000	\$6,000	\$51,000
Birmingham RTB	0.850%	\$46,000	\$6,000	\$52,000
Bloomfield RTB	1.108%	\$60,000	\$8,000	\$68,000
<b>Total</b>	<b>100.000%</b>	<b>\$5,413,000</b>	<b>\$728,000</b>	<b>\$6,141,000</b>

- The purpose of this table is to provide a general estimate of the total paid by each WRC customer community toward the Highland Park Bad Debt based on the current share allocations. It does not reflect the actual amount paid by each individual customer as the shares and amounts paid have changed each year. The estimate is being provided in response to requests from the customer communities to better understand the magnitude of the amount.
- The estimated amount per customer was determined as follows:

$$\begin{aligned}
 & \text{EFSD HP Bad Debt from GLWA} \times \\
 & \text{Community \% share of EFSD for 2023} \\
 & = \text{Estimated Amount per Customer}
 \end{aligned}$$

- Upon repayment of the Highland Park Debt, the funds are expected to be retained by GLWA to offset increasing operation and capital cost. Customers should not expect a refund check in the future.

**TABLE 3. George W. Kuhn Drain Drainage District**

	2023 Sewage Allocation %	2023 Storm Allocation %	Total Highland Park Bad Debt Estimate	Portion of 2023 Sewer Charges for Highland Park Bad Debt	New Total Highland Park Bad Debt Estimate
	<i>Estimated Amount Per Customer</i>				
City of Berkley	4.128%	6.4895%	\$415,000	\$50,000	\$465,000
Village of Beverly Hills	0.274%	0.8369%	\$44,000	\$5,000	\$49,000
City of Birmingham	3.061%	4.8837%	\$311,000	\$38,000	\$349,000
City of Clawson	3.036%	5.9262%	\$352,000	\$43,000	\$395,000
City of Ferndale	5.650%	10.2885%	\$625,000	\$76,000	\$701,000
City of Hazel Park	4.077%	2.2554%	\$240,000	\$29,000	\$269,000
City of Huntington Woods	1.890%	2.4671%	\$169,000	\$20,000	\$189,000
City of Madison Heights	9.236%	6.5410%	\$603,000	\$73,000	\$676,000
City of Oak Park	7.638%	13.6383%	\$834,000	\$101,000	\$935,000
City of Pleasant Ridge	0.888%	1.3390%	\$87,000	\$10,000	\$97,000
City of Royal Oak	18.886%	29.7028%	\$1,899,000	\$229,000	\$2,128,000
Royal Oak Twp	0.908%	1.2775%	\$85,000	\$10,000	\$95,000
City of Southfield	6.494%	7.7156%	\$551,000	\$67,000	\$618,000
City of Troy	32.596%	2.4799%	\$1,286,000	\$155,000	\$1,441,000
Detroit Zoological Park	1.097%	0.3364%	\$54,000	\$6,000	\$60,000
County of Oakland	0.000%	1.5274%	\$62,000	\$8,000	\$70,000
Rackham Golf Course	0.141%	0.1913%	\$13,000	\$2,000	\$15,000
State Of Michigan	0.000%	2.1035%	\$86,000	\$10,000	\$96,000
<b>Total</b>	<b>100.000%</b>	<b>100.0000%</b>	<b>\$7,716,000</b>	<b>\$932,000</b>	<b>\$8,648,000</b>

- The purpose of this table is to provide a general estimate of the total paid by each WRC customer community toward the Highland Park Bad Debt based on the current share allocations. It does not reflect the actual amount paid by each individual customer as the shares and amounts paid have changed each year. The estimate is being provided in response to requests from the customer communities to better understand the magnitude of the amount.
- The estimated amount per customer was determined as follows:

$$\begin{aligned}
 & \text{GWK HP Bad Debt from GLWA} \times \\
 & \text{Community \% share of GWK for 2023} \\
 & = \text{Estimated Amount per Customer}
 \end{aligned}$$

- Upon repayment of the Highland Park Debt, the funds are expected to be retained by GLWA to offset increasing operation and capital cost. Customers should not expect a refund check in the future.

**Agenda Item No. 6**

Engineering Work Order



## Oakland-Macomb Interceptor Drain Drainage District

---

**TO: Michael Gregg, Chairperson  
Oakland-Macomb Interceptor Drain Drainage Board**

**FROM: Joel Brown, P.E. Oakland County Water Resources Commissioner's Office  
Stephen Downing, Macomb County Public Works Commissioner's Office**

**SUBJECT: NTH EWO for Emergency Structural Inspection of the OMID Control  
Structure Gates**

**DATE: April 20, 2022**

On January 14, 2022, HESCO, Inc (HESCO) discovered that one of the guide rails for Control Structure No. 6 (CS-6) sluice gate had failed causing the gate to separate from the bulkhead, ultimately damaging the actuator rod. The failure of the guide rail appeared to be due to loose, missing or otherwise corroded bolts. The gate was subsequently removed and repair parts have been ordered, with an expected delivery date of August 2022. We note that this gate is not currently needed for flow control operations.

Due to the similar age of the other control structures, we believed it was imperative to perform an emergency structural assessment of the other gates: CS-6, CS-7 and CS-8, as well as CS-6. NTH has previously done such assessments for the OMIDDD in the past and has extensive structural knowledge of all the gates. As such, we requested NTH perform the structural inspection in conjunction with HESCO, who also performed general maintenance inspection of the mechanical gate components. The structural inspection included manned entry into each control structure to structurally evaluate the sluice gate, bulkhead gate and ancillary components (including welds) by visually checking for material integrity (sectional loss) and overall structural soundness. These inspections were ultimately performed in late January-February 2022. During these inspections, bolts on the gates were replaced/and/or tightened to ensure the sluice gate would remain in place and functional for the foreseeable future. We anticipate complete replacement and/or refurbishment of gate components in early 2023 as part of an overall control structure upgrades project.

NTH has generated the attached April 5, 2022 proposal, which details the cost for this effort. (Note: HESCO services were provided under their general maintenance contract). An Engineering Work Order has been created to modify NTH's existing contract #2603 to include the above services for a not-to-exceed amount of \$10,022. There are sufficient funds in the major maintenance reserves to cover these costs. NTH is to prepared to begin immediately on these tasks.

**Requested Action: Approve the attached Engineering Work Order to increase contract #2603 by a not-to-exceed amount of \$10,022 for the above services.**

**OAKLAND COUNTY WATER RESOURCES COMMISSIONER**

One Public Works Drive

Phone: (248) 858-0958

Waterford, Michigan 48328-1907

No. \_\_\_\_\_ - \_\_\_\_\_

**ENGINEERING WORK ORDER**FOR: Additional OMIDDD Maintenance Engineering ServicesAmendment to Contract #2603 For Additional OMID Control Structure Inspection ServicesTO: NTH Consultants, Ltd. DATE: 4/11/2022**DESCRIPTION****Section A-Engineering Services and Section C Compensation for Engineering Services, Item No. Additional Special Services and Exhibit D – Estimated Fees**

This Engineering Work Order (EWO) is required to define specific additional tasks and compensation related to the Oakland-Macomb Interceptor Drain (OMID) maintenance engineering activities that falls under the aforementioned sections of contract #2603. This EWO serves as your approval for additional structural inspection services for Control Structure Nos. 5, 6, 7 and 8 in accordance with your attached April 5, 2022 proposal. Such services are as follows:

- Perform manned confined space entry into each control structure.
- Structurally evaluate the sluice gate, bulkhead gate and ancillary components (including welds), visually checking for material integrity (sectional loss) and overall structural soundness.
- Provide a report summary of findings, along with any recommendations.

The associated fees for the above tasks are \$10,022.

**Fees for this Engineering Work Order shall be billed on a time and material basis according to the contract standard fee and rate schedule as modified by your proposal. The total amount of the Engineering Services Agreement is to be increased by a not to exceed amount of \$10,002. This amount is not to be exceeded without written authorization from the Oakland-Macomb Interceptor Drain Drainage District (OMIDDD) Board.**

**PREPARED**      **DATE:** \_\_\_\_\_

**RECOMMENDED**      **DATE:** \_\_\_\_\_

By: Joel Brown, P.E.  
Project Engineer  
OCWRC

By: Stephen Downing, P.E.  
Construction and Maintenance Manager  
MCPWO

**ACCEPTED**      **DATE:** \_\_\_\_\_

**APPROVED**      **DATE:** \_\_\_\_\_

By: Jeff Jaros, P.E.  
President  
NTH Consultants, Ltd.

By: Sid Lockhart, P.E.  
Special Projects Manager  
OCWRC

**Approved by Drainage Board on:** \_\_\_\_\_



## Oakland-Macomb Interceptor Drain Drainage District

---

**TO:** Michael Gregg, Chairperson  
Oakland-Macomb Interceptor Drain Drainage Board

**FROM:** Joel Brown, P.E. Oakland County Water Resources Commissioner's Office  
Stephen Downing, Macomb County Public Works Commissioner's Office

**SUBJECT:** Approval of ASI EWO for NESPS Pumping and Electrical Upgrades Project  
Additional METCO Construction Contract Administration Services

**DATE:** April 20, 2022

As part of the Northeast Sewage Pumping Station (NESPS) Pumping and Electrical Upgrades Project, METCO Services, Inc, under contract with Applied Science Inc., has performed a number of additional design and construction contract administration services that were outside their original scope of work. Such services include the following:

1. Electrical manhole underpinning changes
2. HVAC panel relocation layout, coordination and design
3. Dry well elevator fire alarm panel addition efforts
4. Expanded fire alarm system development within the existing NESPS
5. Additional indoor and outdoor lighting design and coordination
6. New wet well pressure sensors design and coordination
7. Security and process fiber optic cable splicing and rerouting to new electrical building
8. Security fiber optic replacement (new concrete ductbank)
9. Temporary rewiring/controls changes due to transformer failure in the summer of 2021
10. Additional painting and coatings scope
11. Additional replacement of (4) lighting panels that are at end of life
12. Wet well elevator electrical additions
13. Mezzanine renovation
14. Provide E-Stop protective devices at all pumps

These changes were either directly requested by the OMIDDD design team or were necessary as a result of field conditions. In addition, it is expected that the project Substantial Completion date may be delayed approximately 5 months to August 2023.

ASI has prepared the appended April 7, 2022 proposal detailing METCO's out of scope services, and the additional costs required to complete the remainder of the CCA work through August 2023, which totals \$284,079.60.

An Engineering Work Order has been created to include the above scope of work and associated fees to ASI's existing contract #5470. ASI and METCO are prepared to begin this work immediately.

**Requested Action: Approve the attached engineering work order to increase ASI's contract #5470 by an amount not to exceed \$284,079.60 for additional METCO Design and CCA services related to the NESPS Pumping and Electrical Upgrades Project.**



**OAKLAND COUNTY WATER RESOURCES COMMISSIONER**

One Public Works Drive

Phone: (248) 858-0958

Waterford, Michigan 48328-1907

No. \_\_\_\_\_

**ENGINEERING WORK ORDER**FOR: OMID NESPS Pumping and Electrical Upgrades ProjectAmendment to Contract #5470 For METCO Additional Design and CCA ServicesTO: Applied Science Inc. (ASI) DATE: 4/11/22**DESCRIPTION****Section A-Engineering Services and Section C Compensation for Engineering Services, Item No. Additional Special Services and Exhibit C – Engineer’s Proposal**

This Engineering Work Order (EWO) is required to define specific additional tasks and compensation related to the OMID NESPS Mechanical and Electrical Upgrades Project that falls under the aforementioned sections of contract #5470. This EWO serves as your approval for compensation of additional construction contract administration (CCA) and design services needed from METCO regarding the following items on the NESPS Pumping and Electrical Upgrades Project as delineated in your attached April 7, 2022 proposal:

1. Electrical manhole underpinning changes
2. HVAC panel relocation layout, coordination and design
3. Dry well elevator fire alarm panel addition efforts
4. Expanded fire alarm system development within the existing NESPS
5. Additional indoor and outdoor lighting design and coordination
6. New wet well pressure sensors design and coordination
7. Security and process fiber optic cable splicing and rerouting to new electrical building
8. Security fiber optic replacement (new concrete ductbank)
9. Temporary rewiring/controls changes due to transformer failure in the summer of 2021
10. Additional painting and coatings scope
11. Additional replacement of (4) lighting panels that are at end of life
12. Wet well elevator electrical additions
13. Mezzanine renovation
14. Provide E-Stop protective devices at all pumps

In addition, it is anticipated that the Substantial Completion on the project will be delayed by approximately 5 months to August 2023. This EWO also covers base CCA scope work for this time extension.

The total cost for the above additional services and baseline CCA scope time extension is \$284,079.60.

**DESCRIPTION (cont'd)**

**Fees for this Engineering Work Order shall be billed on a time and material basis according to the rate schedules included with the proposal. Subconsultants and expenses are allotted a markup of 5%. The total amount of the Engineering Services Agreement is to be increased by a not to exceed amount of \$284,079.60. This amount is not to be exceeded without written authorization from the Oakland-Macomb Interceptor Drain Drainage District (OMIDDD) Board.**

**PREPARED**      **DATE:** \_\_\_\_\_

**RECOMMENDED**      **DATE:** \_\_\_\_\_

By: Joel Brown, P.E.  
Project Engineer  
OCWRC

By: Stephen Downing, P.E.  
Construction and Maintenance Manager  
MCPWO

**ACCEPTED**      **DATE:** \_\_\_\_\_

**APPROVED**      **DATE:** \_\_\_\_\_

By: John Michalski, P.E.  
Vice President  
Applied Science, Inc..

By: Sid Lockhart, P.E.  
Special Projects Manager  
OCWRC

**Approved by Drainage Board on:** \_\_\_\_\_

## **Agenda Item No. 7**

### **Change Orders**

**CHANGE ORDER NO. TWENTY-ONE**

Oakland Macomb Interceptor Drain, Drainage District (OMIDDD)

For Construction of the Pump and Electrical Upgrades Project

Northeast Sewage Pumping Station (NESPS)

Located in the City of Detroit, Wayne County, Michigan

**CONSTRUCTION MANAGER,  
AT RISK (CMAR)  
Walsh Construction Co. II, LLC**

**Authorization for: Electrical Load Changes**

- 1.) MCC Load revisions for direct fired Unit Heaters
- 2.) Install an additional conduit for power feed for the Magnetic Flowmeters located at each sewage pump.
- 3.) Provide a 120v circuit for the Trane Temperature Control in the Electrical Room control panel.
- 4.) Provide conduit and wiring interface between the Motor Starter and the "Ovation RTU" equipment for various NESPS equipment operations.

\*\*\*\*\*

Address:

Walsh Construction Co. II LLC  
3031 West Grand Blvd., Suite 640  
Detroit, MI 48202

Change Order No. 21 Date: April 05, 2022

	Location-Description-Reason	Unit	Est. Quant.	Unit Price	Amount Increase	Amount Decrease
21 -1	<p><b>LOCATION:</b></p> <p>The Northeast Sewage Pumping Station; Detroit, Wayne County, Michigan</p> <hr/> <p><b>DESCRIPTION: (Change/ Add):</b></p> <p>Provide additional conduit and wiring to re-feed the existing Unit Heaters from the new Motor Control Centers # 2 and # 3.</p> <p><b>REASON:</b></p> <p>The existing NESPS building heating units were called out for demolition in the original contract drawing, but subsequently design changes allow for their continued use. However, alternative power feed circuits requiring additional conduit and wiring were required to provide power to the units from MCC #2 and MCC#3</p> <p>Attachment: Walsh PCI No.: 970107</p>	LS	1 ea.	\$18,893.26	\$18,893.26	-0-

**OMID DD NESPS; Pump & Electrical Upgrades Project; C.O. # 21**

	Location-Description-Reason	Unit	Est. Quant.	Unit Price	Amount Increase	Amount Decrease
21 -2	<p><b>Description: (Extra/ Add):</b></p> <p>Provide an additional conduit to facilitate installation of an additional special sensor cable for the Magnetic Flow Meter installation at each sewage pump.</p> <p><b>REASON:</b></p> <p>The Contract plans indicate the use of existing "typical" flexible conduits for Sewage Pumps # 1 through # 6 for routing of Magnetic Flow Meter Sensor cables. However, the replacement flow meters require a second sensor cable for each meter that could not be installed in the existing single cable conduit. Accordingly, a second conduit run was required for power from the flowmeter transmitter to the flowmeter element.</p> <p>Attachment: Walsh Construction PCI No. 970118</p>	LS	1 ea.	\$10,758.39	\$10,758.39	-0-
21 -3	<p><b>DESCRIPTION (Extra/ Add):</b></p> <p>Install a 120 v electrical circuit to power the Trane Temperature Control ("Thermostat") in the new Electrical Control Room.</p> <p><b>REASON:</b></p> <p>Installation of the new HVAC equipment in the Electrical Room disclosed the need for an independent 110v power source to operate the Temperature Control Unit in the Electrical Control Room. A new circuit was provided for the unit from Lighting Panel 2.</p> <p>Attachment: Walsh PCI # 970124</p>	LS	1ea	\$1,765.33	\$1,765.33	-0-
21 -4	<p><b>DESCRIPTION (Extra/Add):</b></p> <p>Install conduit and cabling to interface the MCC Motor Starters and the Ovation data system.</p>	LS	1 ea.	\$11,706.01	\$11,706.01	-0-

**OMID DD NESPS; Pump & Electrical Upgrades Project; C.O. # 21**

	Location-Description-Reason	Unit	Est. Quant.	Unit Price	Amount Increase	Amount Decrease
21 -4	<p><b>REASON:</b></p> <p>At the Low Voltage Motor Control Centers # 1 through #3, there exists several motor starters for process equipment (i.e., air compressor, Exhaust Fan # 1 and #2, Non-Potable Water Booster Pump, and the Temporary recirculation pump) but no hard wired interface connecting this equipment to the Ovation RTU. The addition of this conduit and wiring will resolve this issue.</p> <p>Attachment: Walsh PCI # 970127</p> <p align="center">*****</p> <p align="center"><b>End of Change Order No. 21 Line Items</b></p>					
					Amount Increase	Amount Decrease
				Totals	\$43,122.99	-0-
				Net Changes (Increase)	\$43,122.99	-----

OMID DD NESPS; Pump & Electrical Upgrades Project; C.O. # 21

Prepared By:  
Lawrence T. Gilbert, P.E.  
NTH Consultants, Ltd.



Date: 04-06-2022

Recommended By:  
John Michalski, P.E.  
Engineer of Design, Applied Science, Inc.

Date: \_\_\_\_\_

Approved By:  
Joel Brown, P.E.  
Project Manager, WRC

Date: \_\_\_\_\_

Approved By:  
Stephen Downing  
Construction and Maintenance Manager, Macomb County Public Works

Date: \_\_\_\_\_

Approved By:  
Sid Lockhart, P.E.  
Manager of Special Projects, WRC

Date: \_\_\_\_\_

Approved by:  
Steve Korth, P.E.  
Manager, WRC

Date: \_\_\_\_\_

All of Construction Manager's contractual obligations remain in place and are applicable to all work and payments identified herein. No adjustment to contract time or price shall be made for these issues except as set out in this, or by a subsequent related, Change Order.

The Construction Manager agrees to do the work described above and agrees to accept Contract time adjustments in full on the basis indicated.

Accepted by:

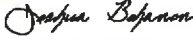
DocuSigned by:  
  
5B8F73D8AD9D445

Date Apr-05-2022 | 2:28 PM CDT

Title

of: Walsh Construction Co. II, Inc.

The Construction Manager is hereby authorized and instructed to do the Work described above in accordance with the terms of the Contract, as amended.

This Change Order No. 21 was approved by the Drainage Board on: Date: \_\_\_\_\_



OMID DD NESPS; Pump & Electrical Upgrades Project; C.O. # 21

**Attachment No. 1 to Change Order No. Twenty-One**

The Engineer has reviewed the items included in this Change Order and confirms that these adjustments to the Contract are reasonable and in accordance with industry standards and the requirements of the Contract.

*Contract Status Summary*  
Change Order No. Twenty-One  
OMID NESPS Pump & Electrical Upgrades Project

*Construction Manager at Risk: Walsh Construction Co. II*

Project Award Date (Pre-Construction Services)	December 16, 2019
Notice to Proceed Date (Construction Phase)	October 23, 2020
Contract Substantial Completion Date	March 24, 2023
Contract Final Completion Date	June 23, 2023
Original GMP Contract Value (Including Control Structure 9)	\$ 42,863,185.19
Pre-Construction Phase, Unused Budget	\$ 70,196.70
C.O. Values, # 7, 8, 9, 10, 11, 12, 13, 14, 15,16, 17,18, 19, & 20	\$ 2,220,290.63
Change Order Value, this C.O. # 21	\$ 43,122.99
<b><i>Adjusted GMP Contract Value (incl. this C.O. # 21)</i></b>	<b>\$ 45,196,795.51</b>

**Agenda Item No. 8**

Construction Estimates

**OAKLAND MACOMB INTERCEPTOR DRAIN DRAINAGE BOARD**  
**Northeast Sewage Pumping Station- Pump and Electrical Upgrades Project**  
**Located in the City of Detroit, Wayne County, Michigan**

**Regular Construction Estimate No. Eighteen**  
**Page One of Two**

**March 01, 2022 through March 31, 2022**

Department No.:	6010101	Account No.:	731472
Fund No.:	84917	Program No.:	149015
Project No.:	1-3309	Activity:	FAC

<b>Construction Manager at Risk:</b>	Vendor # 23191	LI 43331; exp. 12/16/22	
Walsh Construction Co.		Date of Contract:	Dec. 16, 2019
3031 West Grand Boulevard, Suite 640		Final Completion Date:	July 28, 2023
Detroit, MI 48202	Contract No. 5977		

---

Orig. GMP amount for Pump & Elec. Upgrades Project, not including CS-9 and Pre-Const. Balance	\$44,107,745.18
Expended Pre-Construction Phase Amount	(\$1,174,363.30)
<i>Unused Pre-Construction Phase Budget</i>	(\$70,196.70)
<i>CS-9 Budget from GMP</i>	(\$3,251,117.72)
NESPS Pump & Elec. Upgrades Original Contract Budget	\$39,612,067.46
Change Orders, This Estimate: C.O. No. 20	\$215,255.18
Previous C.O.s: (C.O.# 7, 8, 9, 10, 11,12, 13, 14, 15, 16, 17, 18 and 19)- <i>Corrected Value</i>	\$2,005,035.45
Unused Pre-Construction Phase Budget	\$70,196.70
<b>Adjusted Construction Contract Amount:</b>	<b>\$41,902,554.79</b>
<hr/>	
Sub-Total To Date: (CS-9 Costs are Not included on this Estimate)	\$21,271,280.32
Less Deductions:	None
Gross Estimate: (Work in Place) Complete = 50.76%	\$21,271,280.32
Less Amount Reserved (Incl. Partial Subcon. Reductions - See Schedule)	\$1,999,600.51
Total Amount Allowed To Date:	\$19,271,679.81
Less Previous Estimates:	\$17,725,673.24
Current Payment Due	<b>\$1,546,006.57</b>
Reserve Pay to Contractor:	\$0.00
Balance to Finish: \$ 20,631,274.47	Accounting Auditor:
<hr/>	
Amount To Be Reserved (From Above: )	\$1,999,600.51
Less Previous Transfers To Reserve (N/I CS-9 Contract Retention)	\$1,827,821.99
<b>Amount of Current Transfer</b>	<b>\$171,778.52</b>

OAKLAND MACOMB INTERCEPTOR DRAIN DRAINAGE BOARD  
Northeast Sewage Pumping Station- Pump and Electrical Upgrades Project  
Located in the City of Detroit, Wayne County, Michigan  
Walsh Construction Co. II; Construction Manager at Risk

Regular Construction Estimate No. Eighteen  
Page Two of Two

3/01/ 2022 through 3/31/ 2022

Prepared by: Lawrence T. Gilbert

Date: 4-8-22

Lawrence T. Gilbert, P.E.; NTH Consultants Ltd.

Recommended by: \_\_\_\_\_

Date: \_\_\_\_\_

John Michalski, P.E., ASI

Recommended by: \_\_\_\_\_

Date: \_\_\_\_\_

Joel Brown, P.E. Oakland County WRC

Recommended by: \_\_\_\_\_

Date: \_\_\_\_\_

Stephen Downing; Macomb County OPWC

Approved for Payment by: \_\_\_\_\_

Date: \_\_\_\_\_

Sid Lockhart, P.E.; Special Projects Manager, Oakland County WRC

Regular Construction Estimate No. 18 (March, 2022)

Approved By Board On: \_\_\_\_\_

**OAKLAND MACOMB INTERCEPTOR DRAIN DRAINAGE BOARD**  
**For Construction of the NI-EA OMID Contract 1 - PCI 4 Rehabilitation**  
**Located in the City of Detroit, Wayne, Michigan**  
**Project ID 1-00000003308**

Regular Construction Estimate No. 13

Period: 3/01/22 through 3/31/22

Department No.:	6010101	Account No.:	731472
Fund No.:	84917	Program No.:	149015
Project No.:	100000003308	Activity:	FAC

Contractor:	Vendor # 29656 Contract # 6323
Marra Services, Inc.	LI # 44838 exp. 1/20/23
700 E. 73 rd. Street	Date of Contract: January 21, 2021
Cleveland, OH 44103	Final Completion Date: September 9, 2022

Original Construction Contract Amount	\$14,732,510.00
Previous Change Orders: No. One	\$664,392.00
Change Orders This Estimate: # Two	\$143,806.88
Total Net Change Orders:	\$808,198.88
<u>Adjusted Contract Amount:</u>	<u>\$15,540,708.88</u>
Sub-Total To Date	\$8,085,517.58
Less Deductions: None	\$0.00
Gross Estimate, Work in Place (52.0% Complete)	\$8,085,517.58
Less Amount Reserved (Max. at 10% of 50% C.V.)	\$777,035.44
Total Amount Allowed To Date:	\$7,308,482.14
Less Previous Estimates	\$6,510,838.58
Net Payment Request To Be Paid To Contractor:	\$797,643.56
Reserve Payment to Contractor:	\$0.00
Balance to Finish: \$7,455,191.30	Accounting Auditor:
Amount to be Reserved from Above	\$777,035.44
Less Previous Transfers To Reserve:	\$723,426.62
Amount of Current Transfer	\$53,608.82

Prepared by: Lawrence T. Gilbert  
 Lawrence T. Gilbert, P.E.; NTH Consultants Ltd.

Date: 04-06-2022

Recommended by: \_\_\_\_\_  
 Saju Sachidanandan, P. E.; NTH Consultants Ltd.

Date: \_\_\_\_\_

Recommended by: \_\_\_\_\_  
 Joel Brown, P.E. Oakland County WRC

Date: \_\_\_\_\_

Recommended by: \_\_\_\_\_  
 Stephen Downing; Macomb County OPWC

Date: \_\_\_\_\_

Approved for Payment by: \_\_\_\_\_  
 Sid Lockhart, P.E.; Special Projects Manager, Oakland County WRC

Date: \_\_\_\_\_

**OAKLAND MACOMB INTERCEPTOR DRAIN DRAINAGE BOARD**

**Segment 2, Contract 3 Project (Base Contract)  
Located in Oakland, Macomb and Wayne County, Michigan**

**Regular Construction Estimate No. 41 FINAL**

March 31, 2019 to March 31, 2022 **FINAL**

Department No.:	6010101	Account No.:	731472
Fund No.:	84915	Program No.:	149015
Project No.:	#1-2232	Activity:	FAC

Contractor: Inland Waters Pollution Control, Inc. 4086 Michigan Ave. Detroit, MI 48210	Contract #3450	Date of Contract: Completion Date: Extended to:	April 21,2015 October 2, 2016 Dec. 31, 2021
---	----------------	---	---

Original Contract Amount:	\$17,965,840.00
Previous Change Orders:	\$ 5,025,414.72
Total Change Orders	\$ 5,025,414.72
<b>Adjusted Contract Amount:</b>	<b>\$22,991,254.72</b>
Less Value of Gatehouse Emergency Repairs <i>(Refer to Separate Estimate Summary)</i>	<i>(\$5,061,080.35)</i>
Sub-Total To Date:	\$ 17,930,174.37
Less Deductions:	\$ -
Gross Estimate: (Work in Place) 100%	\$ 17,930,174.37
Current Value of Retainage <i>(Partial Retainage Returned to Project Account)</i>	\$ 80,000.00
Total Amount Allowed To Date:	\$ 17,930,174.37
Less Previous Estimates: Paid to Date	\$ 18,009,266.41
Overpayment Value (Final OCIP Deduct and Balancing Adjustments)	(\$79,092.04)
Payment to Contractor (Retainage Value less Overpayment : \$80,000.00 - \$79,092.04)	\$907.96
<b>Balance of Contract To Date</b>	<b>\$0.00</b>
Amount To Be Reserved (From Above)	0.00
<b>Transfer of Reserve:</b> \$79,092.04 transfer to Project Account , plus	0.00
\$907.96 transfer to Contractor (Total Transfer = \$80,000.00)	\$0.00

Prepared by: \_\_\_\_\_ Date: \_\_\_\_\_  
Lawrence T. Gilbert, P.E.; NTH Consultants, Ltd.

Recommended by: \_\_\_\_\_ Date: \_\_\_\_\_  
Saju Sachidanandan, P.E.; NTH Consultants Ltd.

Recommended by: \_\_\_\_\_ Date: \_\_\_\_\_  
Joel T. Brown, P.E., Oakland County, WRC

Recommended by: \_\_\_\_\_ Date: \_\_\_\_\_  
Stephen Downing, Macomb County OPWC

Approved For Payment: \_\_\_\_\_ Date: \_\_\_\_\_  
Sid Lockhart, P.E., Special Projects Manager

Regular Construction Estimate # 41 **FINAL**

Approved By Board On: \_\_\_\_\_

**OMID SEGMENT TWO, CONTRACT THREE**

**Inland Waters Pollution Control, Inc.**

**Final Accounting Summary - Base Contract**

**04-12-2022**

<b>Adjusted Contract Value (Incl. C.O. # 1 through 9)</b>	<b>\$24,067,444.60</b>
<b>C.O. # 10</b>	<b>( 1,027,068.88)</b>
<b>C.O. # 11</b>	<b>( 49,121.00)</b>
<b>Subtotal</b>	<b>\$22,991,254.72</b>
<b>Less Gatehouse Repairs (Incl. C.O. 2-K)</b>	<b>( 5,061,080.35)</b>
<b>Subtotal</b>	<b>\$17,930,174.37</b>
<b>Paid to Date ( N/I Retainage)</b>	<b>18,009,266.41</b>
<b>Amount Over-Billed</b>	<b>79,092.04</b>
<b>Retainage Value (Currently Held)</b>	<b>\$ 80,000.00</b>
<b>Value Returned to Project Account (From Retainage)</b>	<b>79,092.04</b>
<b>Final Value Due (Retainage value, less over-billing)</b>	<b>\$ 907.96</b>

**OAKLAND MACOMB INTERCEPTOR DRAIN DRAINAGE BOARD**  
**For Construction of the Oakland Macomb Interceptor Drain Contract 3, Change Order 2-E**  
**NESPS Emergency Gatehouse Repair**  
**Located in the City of Detroit, Wayne County, Michigan**

Regular Construction Estimate No. 20 **FINAL**

March 31, 2019 to March 31, 2022 **FINAL**

Department No.: 6010101  
Fund No.: 84915  
Project No.: #1-2232

Account No.: 731472  
Program No.: 149015  
Activity: FAC

Contractor:  
Inland Waters Pollution Control, Inc.  
4086 Michigan Ave.  
Detroit, MI 48210

Date of Contract: April 21, 2015  
Completion Date: October 2, 2016  
Extended to: N/A

Contract #3450

Original Contract Amount:			\$4,979,828.31
Previous Change Orders: Numbers 2F, 2G, 2H, and 2I		\$	289,435.02
Change Orders, This Estimate: No. 2-J and 2-K		\$	(208,182.98)
Total Net Change Orders:			\$81,252.04
<b>Adjusted Contract Amount:</b>			<b>\$5,061,080.35</b>
<hr/>			
Sub-Total To Date: (Sheet 2 of 2 Column 7)		\$	5,061,080.35
Less Deductions: (Sheet 2 of 2 Column 7)		\$	-
Gross Estimate: (Work in Place)	100.00%	\$	5,061,080.35
Less Amount Reserved: Final Retainage Value returned to OMID DD, per C.O. # 2-K		\$	-
Total Amount Allowed To Date:		\$	5,061,080.35
Less Previous Estimates:		\$	5,054,361.77
Net Payment Request To Be Paid To Contractor:			\$6,718.58
Reserve Payment to Contractor			\$0.00
<b>Balance of Contract To Date</b>	<b>\$0.00</b>	<b>Accounting Auditor:</b>	
Amount To Be Reserved (From Above)			0.00
Less Previous Transfers To Reserve:			0.00
Amount of Current Transfer:			\$0.00

Prepared by: \_\_\_\_\_  
Lawrence T. Gilbert, P.E.; NTH Consultants, Ltd.

Date: \_\_\_\_\_

Recommended by: \_\_\_\_\_  
Saju Sachidanandan, P.E.; NTH Consultants Ltd.

Date: \_\_\_\_\_

Recommended by: \_\_\_\_\_  
Joel T. Brown, P.E., Oakland County, WRC

Date: \_\_\_\_\_

Recommended by: \_\_\_\_\_  
Stephen Downing, Macomb County OPWC

Date: \_\_\_\_\_

Approved For Payment: \_\_\_\_\_  
Sid Lockhart, P.E., Special Projects Manager

Date: \_\_\_\_\_

Regular Construction Estimate # 20 **FINAL**

Approved By Board On: \_\_\_\_\_



**Agenda Item No. 9**

Report/Update – Status of OMID  
Project, Segments 1 through 4, NESPS,  
NI-EA

# Oakland Macomb Interceptor Drain (OMID) Repairs

## Project Progress Update

Prepared by:

F. Klingler, P.E., B. Kelly, P.E., FK Engineering Assoc.  
S. Sachidanandan, P.E., L. Gilbert, P.E., NTH Consultants, Ltd.  
J. Michalski, P.E., Applied Science, Inc.; T. Moore, Metco Services, Inc.  
J. Matteo, P.E., Jacobs Engineering, Inc.

### April 20, 2022 OMIDDD Board Meeting

---

The following provides a status update as of the writing of this report (April 11, 2022) for the work completed for the Oakland-Macomb Interceptor Drain Repair Program (SRF Segments 1-4; Contract 7 PCI-4 repairs; Maintenance Repairs in PCI-5 through PCI-11A; Control Structure Modifications; NIEA Repairs; NESPS Upgrades; Odor/ Corrosion Control System, and other related work):

#### SRF Segment 1 Status:

**Contracts 1&2: Complete**

**System-wide Odor/Corrosion Study – Contract Extended to 5/15/2022**

Engineering Consultant: Jacobs

#### Project Budget Summary (including EWOs):

- |   |              |
|---|--------------|
| • Adjusted Project Budget (including EWOs and Fan Testing Allowance): | \$567,447.00 |
| • Total Spent (through May 2021):                                     | \$566,441.58 |
| • Additional Data Gathering Budget (under NTH):                       | \$84,926.00  |
| • Additional Data Gathering Expenditure to date:                      | \$1,282.00   |

#### Status of Major Project Tasks:

- System-wide Odor/Corrosion Study and additional requested work is substantially complete. Jacobs delivered on May 28, 2021 a draft technical memorandum that summarizes the NI-EA Phase 1 odor sampling recently performed at the NESPS and in PCI-4. Jacobs is currently performing additional data gathering (H2S and pressure readings) under NTH Contract #2603 within the NIEA and OMID portions of the system to further evaluate impacts from flow control sequencing. Final Report will be updated to reflect new data.

#### SRF Segment 2 Status:

**Contract 3 (Base Contract & C.O. 2E-2J): Complete**

#### SRF Segment 3 Status:

**Contract 4: Complete**

# April 20, 2022 OMIDDD Board Meeting

---

## SRF Segment 4 Status:

### Contract 5A/5B: Complete

- City of Utica Use Agreement for access paths is pending; awaiting final authorization.

### Contract 6: Complete

### Contract 7 (NIEA 110 feet of Emergency Rehab) – Complete

Deterioration noted in early 2021 is to be repaired by slip lining this area using GFRPMP, currently planned under NIEA OMID Contract 1 (PCI-4 Rehabilitation).

## NESPS Odor/Corrosion Control System (No Segment or Contract No.): Construction Complete

## NESPS & OMID Maintenance & Repairs Status:

**Amt Invoiced:** \$199,701 thru July, 2021 out of current \$353,000 ASI engineering budget; Does not include Metco budget for ongoing flow control, maintenance, and coordination.

**Schedule Status:** Ongoing

### Status of Emergency Contingency Plan for pumping during total power loss or other catastrophic system failure:

- Mersino Dewatering is under contract for standby emergency bypass pumping.
- The OMIDDD Project Team is currently finalizing design for an approach for keeping the 15 Mile Road bypass pumping arrangement (initially constructed in summer 2021) intact. Plans are now in place for the existing bypass piping remaining on site and being modified to below grade piping, pending final agreement with ITC.
- Remaining items in the final emergency plan include punch-list and optimization steps for electrification, the modification of one manhole, modifications at the 15-Mile Road Site, and overall optimization of the Emergency Plan per above.

### Additional work being performed under Metco Maintenance Contract for NESPS:

- Flow control operations related to OMID/MID/NIEA sewer repair and upgrade projects are ongoing.
- Mechanical and Electrical corrective/preventative maintenance schedules continue.
- Coordination between GLWA, MID, NESPS, and Pump/Electrical Upgrade Project has not affected station operations nor hindered performance or abilities to meet demands.
- Wet well sediment inspection and barscreen cleaning are now quarterly tasks. The

## April 20, 2022 OMIDDD Board Meeting

---

next effort is scheduled for May 27, 2022. Sediment level has plateaued and, in some cases, dropped. Based on the data and observations, the wet wells appear to be self-regulating/cleaning, with the exception of long term accumulation of larger debris and cemented material which is not drawn into the pumps. See graphs below.

- Bar-screens have been monitored regularly over the past 2 years and cleaned of accumulated ragging as necessary. A summary of water level data during this period summarizing water drops across the bar racks was conducted and is inconclusive. In general, based on observation and recollection of those cleaning the ragging, the accumulation appears to have been decreasing since about summer 2020, when significant ragging was noted. The bar racks will continue to be monitored for ragging and cleaned on a quarterly basis or if otherwise needed. See below for water level drops across bar racks within the NESPS wet well.
- The OMIDDD Project Team is continuing to review past wet well/bar screen data. This effort will be used in developing best practices maintaining overall de-ragging and sediment removal efforts. Also, the team continues to research methods for using high pressure water onsite for bar screen cleaning. National Liquid Blasting has now submitted a Proposal for a “Proof of Concept” approach to the cleaning methodology, and it is under review by the Team members in comparison to the current approach of periodic cleaning.
- A NESPS Controls Workshop with the OMID team and GLWA has been scheduled. This workshop is designed around new operational parameters and control strategies.
- NESPS Health and Safety Plan finalized.

# April 20, 2022 OMIDDD Board Meeting

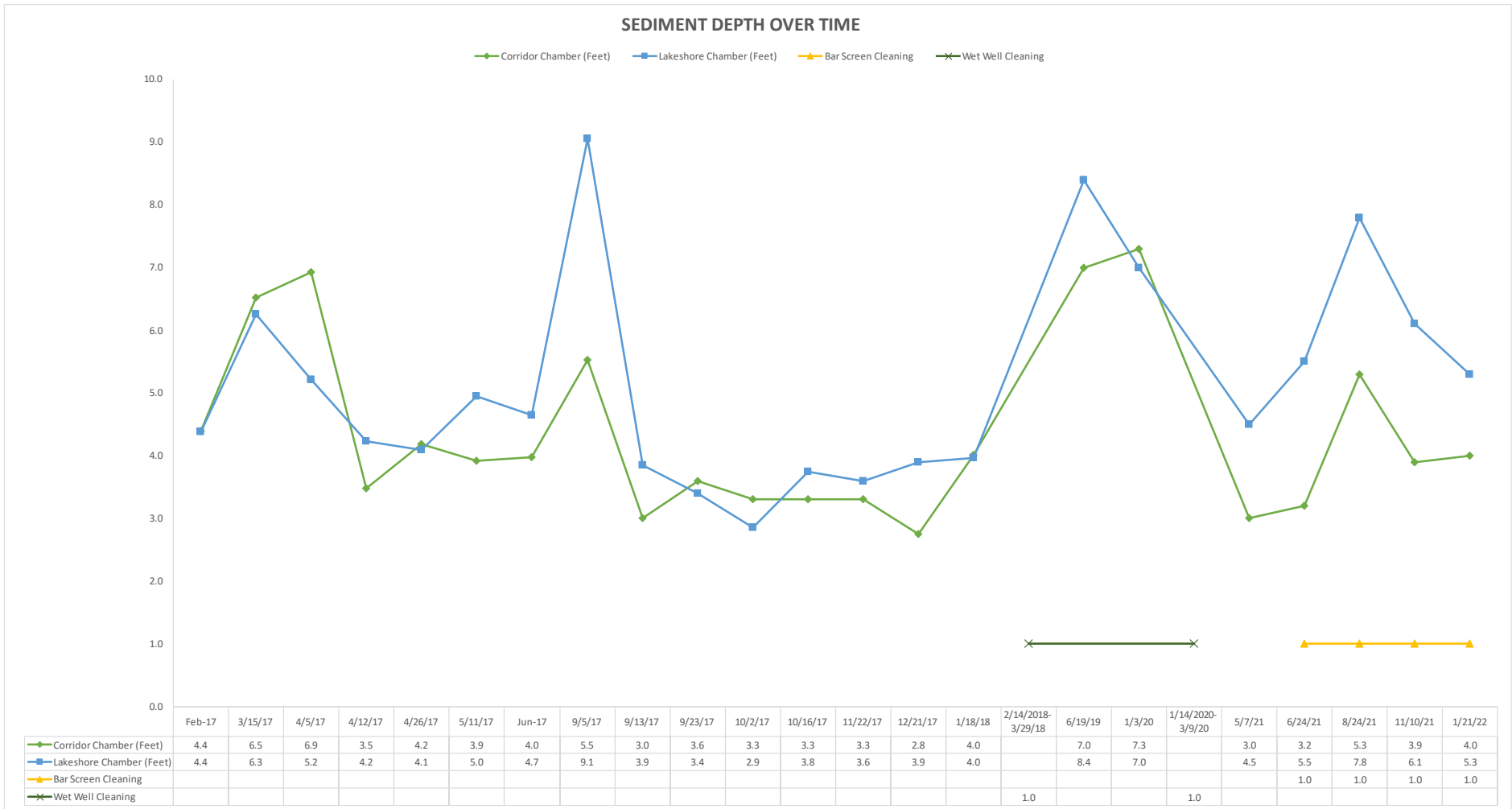

**Sediment depth over time at the NESPS wet well**

# April 20, 2022 OMIDDD Board Meeting

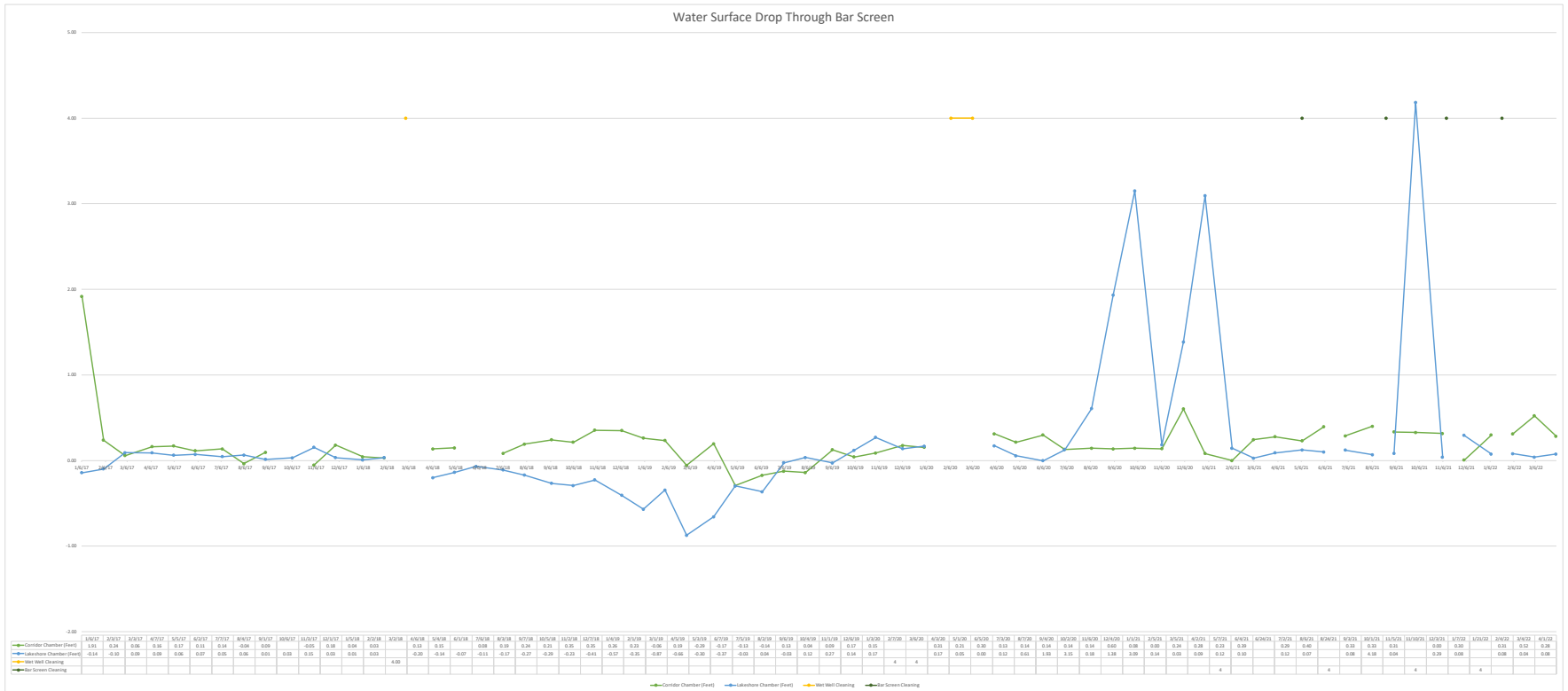

Water level drop over time at the NESPS wet well (Preliminary)

# April 20, 2022 OMIDDD Board Meeting

---

## Overall Station Performance Report:

- Sanitary Pumps #2 #4, #5, and #6 ready for duty. Total pump capacity equals 500-cfs
- Sanitary Pump #2 VFD (Variable Frequency Drive) has been resolved (1) HVAC Fan Motor failure on two of the four Bard AC units corrected. All four (4) Bard AC units modified with new more robust motors. (2) One of the three VFD cell cabinet exhaust blowers seized. Rotor has sent the exhaust blower out for re-build. The pump is back in regular rotation.
- Sanitary Pump #6 exciter insulation resistance tested low during Preventative Maintenance checks. Rotor is looking into the cost benefit of addressing based upon service life expectancy. Currently performance is in line with normal operations.
- Specific data logging software has been installed within the VFD drive PLC. Siemens maintains the ability to monitor VFD performance and fault/trip conditions.
- Rotor integrated the existing Eaton Power Expert (Quality Power Monitoring Meter) located on the VFD Sanitary Pump #4 switchgear into the OMID SCADA system. We can now monitor/trend incoming DTE electrical power.
- Sanitary Pump #1 remains out of service as part of the upgrade project. The Pump #1 knife gate valve has been refurbished and installed. (see NESPS Rehab Report below)
- Investigations are under way to repair/replace leaky mechanical seal on wet well dewatering pump. This has not impacted pump performance.
- New transformer (T3) has been energized and tied to the existing switchgear. Station now in preferred "double-ended" status whereby T3 and T4 utility transformers are both under load conditions.
- NEXGEN asset management in use.
- Gas detection faults/alarms have been corrected. Protocols related to alarming have been modified by OMIDDD and in use.
- NESPS HVAC system performing as designed. Minor tweaking on-going.
- Bio Filter performance normal with no odor complaints or issues to report. Parameters checked daily and shared with Bio Aire on a weekly basis.
- Overall General Housekeeping tasks in order. Minor maintenance activities addressed in a timely manner.

## Control Structures Performance Report (CS-5, CS-6, CS-7, CS-8):

- Daily flow control operations now support MID/OMID/NIEA repair and improvement projects.
- All LOTO protocols are in-place with no major issues to report.
- System-wide communications are good.
- CS-6 gate remains out of service. HESCO salvaged the counter-balance valve from the damaged CS-6 gate and will re-use it at CS-3. This will restore operability to MID CS-3 gate #1.
- Refurbishment plan of CS-6 are underway, quotes and scope of work are being identified. Details will follow.
- Preventative maintenance tasks are completed. Emergency inspections are completed. All inspections and preventative maintenance are complete. Minor issues addressed. Reports are on file. Corrective work orders have been generated in NEXGEN and are in progress
- CS-7 in stand-by mode ready for service.
- CS-8 in stand-by mode ready for service.
- CS-5 in stand-by mode ready for service.
- CS-9 in stand-by mode ready for service.
- PCI-5 Hobas lining repair scheduled for upcoming spring.

## April 20, 2022 OMIDDD Board Meeting

---

- Routine daily rounds and inspection made with no major maintenance issues to report at this time.

### Other System Operation Issues

- O&M Manual currently being revised to include new structures, recently modified structures, new monitoring equipment, and recent inspection and repair status.
- EGLE has informally agreed to consent to use of all flow control structures for long term flow control. Request for formal consent is promised but not yet received.

## OMID Control Structure Upgrades Status:

**Amt Invoiced:** \$69,772 Engineering services to date; Total design and construction budget currently established as \$500,000 (including contingencies and admin/legal).

**Schedule Status:** Construction of cover mods substantially complete 8/14/20

- Hatch and Access improvements complete, CSM Contract closed-out.
- CS-5, CS-6, CS-7, and CS-8 mechanical repairs have been completed by HESCO and control structures are in stand-by mode, ready for service.
- HESCO has provided a study of control structures that evaluates long-term operability. This document is currently under review, and design for upgrades is in planning stages (ASI preparing a design scope and budget for consideration).

## OMID System 3-Year Spot Repairs and 6-Year Inspection Status:

**Amt Invoiced:** Total design and construction budget for 3-Year repairs currently is established as \$1,352,801 (including contingencies and admin/legal).

### Schedule and Progress Status:

- Remaining 3-year spot repair work consists of step removal at one manhole in PCI-8, delayed due to access issues and timing of other work.
- The 6-Year inspection began July 8, 2021. After delays due to flow control, inspections have resumed and are nearing completion.
- Some damage noted to the CIPP Liner installed in 42" section of PCI-11A. Current plan is for Doetsch to remove the damaged section, grind the edges, and assess if anything more is necessary.

## NIEA Repairs (Design/Construction)

**Amt Invoiced:** \$2,200,675 out of currently projected study/design budget of \$2,400,570; Total design and construction budget currently is \$44,168,770 (including contingencies and admin/legal). The current value of construction work (Contract 1 only) completed is \$7,234,266.20 that represents 47% of the Contract sum.

**Schedule Status:** Contract 1: The Project Owner, the Engineer, and the Contractor have resolved current schedule delay issues related to Flow Control Management that resulted in an extension of Contract Time as well as a schedule replenishment of available "Operational Control" days. This time extension in addition to a more aggressive work schedule by the Contractor has resulted in a projected on-time completion for an adjusted Substantial Completion date of December 2, 2022. Currently, the



## April 20, 2022 OMIDDD Board Meeting

Contractor is operating approx. 15 days behind the adjusted schedule, but anticipates this shortfall can be made up with productive lining work commencing in the near future.

Contract 2: 100% design work complete; expected to bid in early to mid-2022 pending permit and easement acquisition resolution and coordination with GLWA projects that impact flow control requirements.

Progress for both contracts is summarized:

### Contract 1 (PCI-4 Rehabilitation):

- Access shaft excavation and liner-plate TERS is complete as is headwall construction and mudmat slab construction. Work is progressing on the wire-saw removal of the upper half of the exposed interceptor in preparation for the start of liner installation. Work is also underway on the preliminary efforts to assemble the Channeline lining segments in preparation for in-tunnel transport and erection of the segments commencing at the NESPS Gatehouse. Current inspections by the Engineering Team has confirmed that 100% of the Channeline segments are now on site, over 90% of the Rockhard SCP segments have been manufactured at the Indiana casting facility, and progress is well underway on the QuakeWrap lining pipe at the Hastings, MI manufacturing facility.
- Geotechnical monitoring of construction activities indicates continuing stable conditions.

### Contract 2 (PCI -18/19 Rehabilitation)

- NI-EA OMID Contract No. 2 PCI-18 & 19 Rehabilitation 100% drawing set has been workshopped with OMIDDD and is ready for advertisement, pending final easements and GLWA agreement.
- Flow control measures necessary to complete Contract 2 work is expected to impact a downstream GLWA project (DB-226). Contract 2 is being structured such that potential interference between the two contracts can be mitigated.
- Current City of Detroit permitting issues are nearly resolved; certain follow-up issues remaining.
- Working with GLWA to develop cost sharing agreement; Draft agreement is currently being reviewed by GLWA Legal.

The **draft** line item schedule and budget are summarized:

Work Item/ Milestone	Estimated Budget Expenditure (Engineering)	Estimated Budget Expenditure (Contractor)	Estimated Delivery Date
Lining Study Final Report	\$126,744		10/30/2019
90%, 100% Design Package			3/20/2020 and 4/28/2020 (Contract 1) 4/16/2021* and TBD* (Contract 2)
MDEQ Submittal (Part 41)			4/28/2020 (Contract 1) Pending* (Contract 2)
Issued for Bid			6/10/2020 (Contract 1) 4/2022* (Contract 2)
Bid Opening			9/30/2020 (Contract 1) April 2022* (Contract 2)
Contract Award and NTP			12/16/2020 and 1/04/2021 (Contract 1) TBD* (Contract 2)
Subtotal - Design	\$2,400,570		
Final Completion of Construction	\$3,500,000	\$35,000,000	12/2/2022 (Contract 1) 10/30/2023 (Contract 2, estimated))

# April 20, 2022 OMIDDD Board Meeting

---



**Pipe carrier on-site**



**Removing crown of  
the Interceptor**

# April 20, 2022 OMIDDD Board Meeting

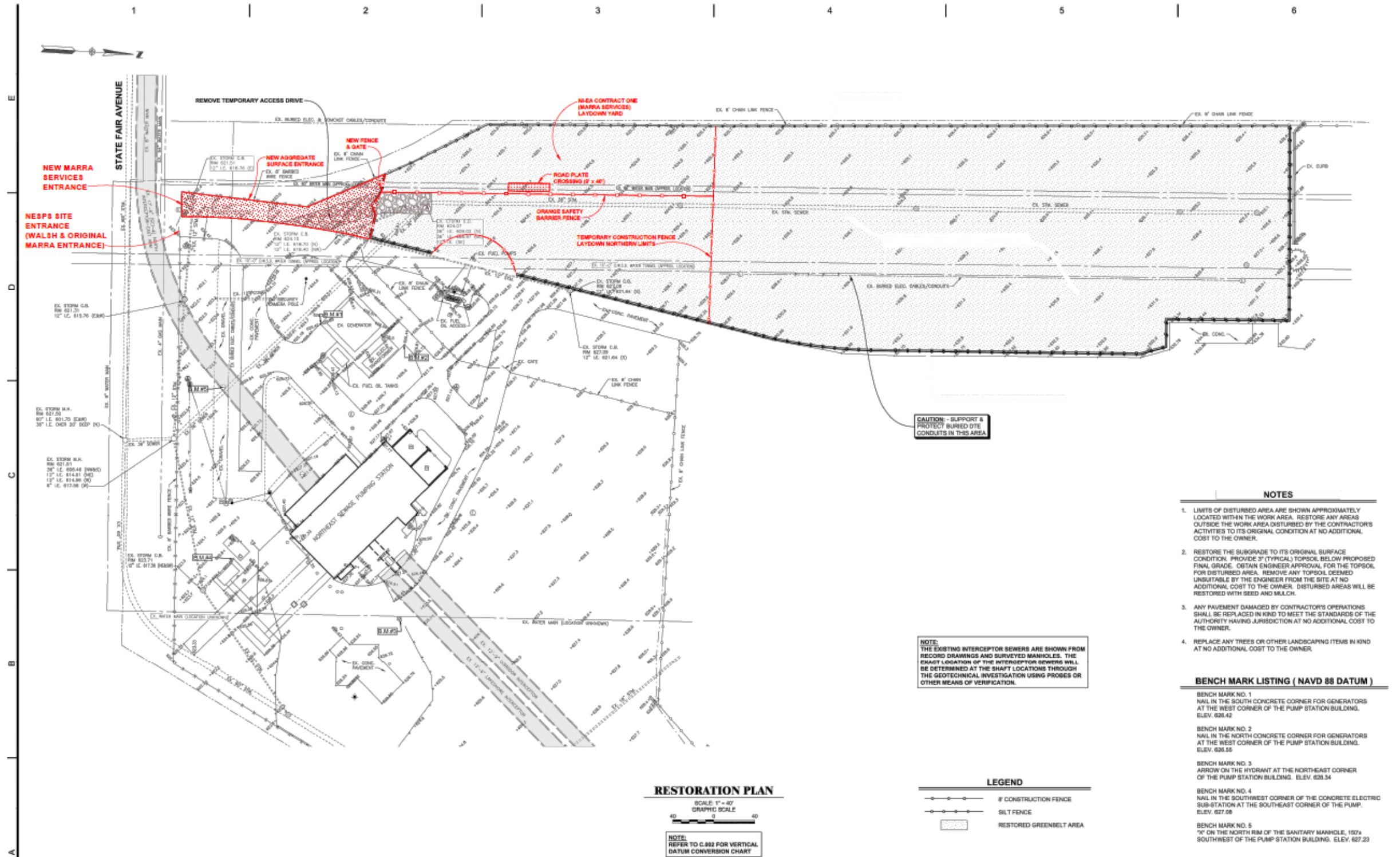

NIEA Contract #1 As-Constructed Laydown Plan depicting new road/entrance

CAUTION - SUPPORT & PROTECT BURIED SITE CONDUITS IN THIS AREA

NOTE: THE EXISTING INTERCEPTOR SEWERS ARE SHOWN FROM RECORD DRAWINGS AND SURVEYED MANHOLES. THE EXACT LOCATION OF THE INTERCEPTOR SEWERS WILL BE DETERMINED AT THE SHAFT LOCATIONS THROUGH THE GEOTECHNICAL INVESTIGATION USING PROBES OR OTHER MEANS OF VERIFICATION.

**NOTES**

- LIMITS OF DISTURBED AREA ARE SHOWN APPROXIMATELY LOCATED WITHIN THE WORK AREA. RESTORE ANY AREAS OUTSIDE THE WORK AREA DISTURBED BY THE CONTRACTOR'S ACTIVITIES TO ITS ORIGINAL CONDITION AT NO ADDITIONAL COST TO THE OWNER.
- RESTORE THE SUBGRADE TO ITS ORIGINAL SURFACE CONDITION. PROVIDE 3" (TYPICAL) TOPSOIL BELOW PROPOSED FINAL GRADE. OBTAIN ENGINEER APPROVAL FOR THE TOPSOIL FOR DISTURBED AREA. REMOVE ANY TOPSOIL DEEMED UNSUITABLE BY THE ENGINEER FROM THE SITE AT NO ADDITIONAL COST TO THE OWNER. DISTURBED AREAS WILL BE RESTORED WITH SEED AND MULCH.
- ANY PAVEMENT DAMAGED BY CONTRACTOR'S OPERATIONS SHALL BE REPLACED IN KIND TO MEET THE STANDARDS OF THE AUTHORITY HAVING JURISDICTION AT NO ADDITIONAL COST TO THE OWNER.
- REPLACE ANY TREES OR OTHER LANDSCAPING ITEMS IN KIND AT NO ADDITIONAL COST TO THE OWNER.

**BENCH MARK LISTING ( NAVD 88 DATUM )**

- BENCH MARK NO. 1  
NAIL IN THE SOUTH CONCRETE CORNER FOR GENERATORS AT THE WEST CORNER OF THE PUMP STATION BUILDING. ELEV. 626.42
- BENCH MARK NO. 2  
NAIL IN THE NORTH CONCRETE CORNER FOR GENERATORS AT THE WEST CORNER OF THE PUMP STATION BUILDING. ELEV. 626.55
- BENCH MARK NO. 3  
ARROW ON THE HYDRANT AT THE NORTHEAST CORNER OF THE PUMP STATION BUILDING. ELEV. 623.34
- BENCH MARK NO. 4  
NAIL IN THE SOUTHWEST CORNER OF THE CONCRETE ELECTRIC SUB-STATION AT THE SOUTH-EAST CORNER OF THE PUMP. ELEV. 627.08
- BENCH MARK NO. 5  
"C" ON THE NORTH RIM OF THE SANITARY MANHOLE, 100% SOUTHWEST OF THE PUMP STATION BUILDING. ELEV. 627.23

**LEGEND**

- CONSTRUCTION FENCE
- SILT FENCE
- ▨ RESTORED GREENBELT AREA

**RESTORATION PLAN**

SCALE: 1" = 40'  
GRAPHIC SCALE

NOTE: REFER TO C.402 FOR VERTICAL DATUM CONVERSION CHART

REV	DESCRIPTION	DATE	BY
1	TOP DESIGN SUBMITTAL	04/20/22	LJU

DESIGNED BY: LJU  
 DRAWN BY: MUS  
 CHECKED BY: JLA  
 PROJECT MANAGER: LJU

ANDERSON, ECKSTEIN AND WESTROCK, INC.  
 Civil Engineers  
 Surveyors  
 Architects

NTH Consultants, Ltd.  
 Infrastructure Engineering  
 and Environmental Services  
 Detroit, MI • Nashville, TN  
 Lansing, MI • Grand Rapids, MI  
 Cleveland, OH

STATE OF MICHIGAN  
 LOUIS J. MORAN, LE  
 No. 3094  
 PROFESSIONAL ENGINEER

NORTH INTERCEPTOR - EAST ARM  
 PCI-4 REHABILITATION

OAKLAND-MACOMB INTERCEPTOR DRAIN (OMID)  
 NORTH INTERCEPTOR - EAST ARM (NI-EA)  
 WAYNE COUNTY, MICHIGAN

LAYDOWN AREA: NESPS PUMP STATION  
 AS-CONSTRUCTED PLAN

WRC  
 WATER RESOURCES CORPORATION  
 AECOM

CAD FILE NAME: NESPS Plans  
 DRAWING SCALE: 1" = 40'

WSP DATE: 16-Apr-20  
 PLOT DATE: 9-Apr-20

DISTRICT ENGINEER NUMBER:  
**C.403**

# April 20, 2022 OMIDDD Board Meeting

---

## NESPS Pump and Electrical Upgrades Project

**Budget Status:** \$1,280,139 billed out of current Design Budget of \$1,382,430; \$968,018 out of the current CCA Budget of \$2,443,262. Total construction budget currently established as \$45,001,517.63, including contingencies, through proposed C.O. #19). The total amount invoiced to date as of March 31, 2022 is \$ 24,529,572.57 (including the now completed and operational Control Structure 9 Bulkhead Gate facility, and adjusted for stored material inclusion in major work activities.), representing 54.25% of the combined project (Pump & Electrical Upgrades and CS-9 Gate Installation).

**Schedule Status:** Currently estimated to be about 5 months behind, resulting from a combination of supply chain and other issues. Contractor has and continues to evaluate alternatives for gaining schedule.

The following Design Team and Construction Services Effort is active:

- The new Sewage Pump # 3 and Motor has now been delivered to the NESPS and is in the process of installation. In addition, Sewage Pump and Motor No. 1 is following closely behind and being readied for installation. Factory performance tests have been conducted with each separate component, and the pump and motor assembly will be re-tested when in place at the NESPS.
- Electrical work on the primary cable installation from the transformers to the new metal clad switchgear is in progress and proceeding without issue.
- A review of alternative energy saving methods and pump sequence remains ongoing, incorporating GLWA SCC comments.
- Construction Phase services (RFIs, Submittals) are ongoing, and the engineering team is reviewing and responding.
- Discharge piping work is underway on Pumps # 1 and # 3, including pressure testing.
- Chemical injection to seal groundwater infiltration at the existing discharge pipe wall penetrations is substantially complete, with final efforts on hold to observe the initial stages of grouting and determine if further measures may be required for final leak control.
- Small diameter conduit runs are being installed in the existing NESPS building with favorable progress, now approaching substantial completion for this activity.
- Pump 1 has been shop tested and is now on site and undergoing installation.
- Knife Gate 1 is refurbished and has been reinstalled on site.
- The **draft** line item schedule and budget are summarized:

Work Item/ Milestone	Design/CCA Budget	Const Budget	Estimated Delivery Date
2 Final Basis of Design			5/31/2019
7 MDEQ Submittal (Part 41 Permit)			4/8/2020 (initial pkg)
8 90% Design Submittal			6/30/20
9 Final Package Development			8/14/2020
Subtotal	\$3,826,000	\$44,100,000	
10 Substantial Completion	\$2,500,000 (est.)	\$44,100,000 (est.)	3/24/2023
11 Final Completion			6/23/2023

# April 20, 2022 OMIDDD Board Meeting

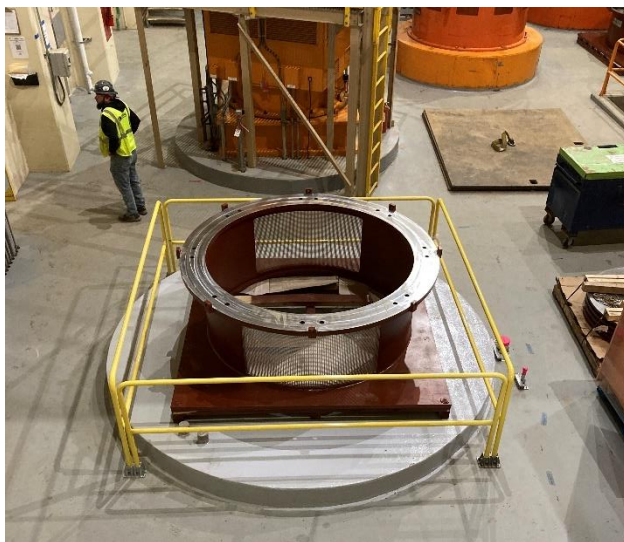

## CS-9 Gate Installation

### Budget Status:

Total construction budget currently established as approximately \$3,314,218.01

### Schedule Status:

Engineering/Design efforts complete; Work is now estimated at 99% complete based on current Progress Payment Applications, and the project is moving through final adjustments for equipment operation and flow control monitoring.

The following work is active:

- All major work is complete and the Hydrogate gate is in regular use for flow control management.
- Site restoration is substantially complete and will be fully completed in Spring 2022.

## April 20, 2022 OMIDDD Board Meeting

- HOBAS representatives and Insurance Adjusters (Builder's Risk Insurance Claim) have been on-site to assess the damage from hatch covers that fell into the sewer. Doetsch Environmental is engaged to provide repair services. Repairs will also be necessary on the platform. This work will be performed in Spring 2022, with efforts underway to provide estimated cost documentation to the Insurance Carrier. Final site restoration will be scheduled following the Hobas lining repair task.

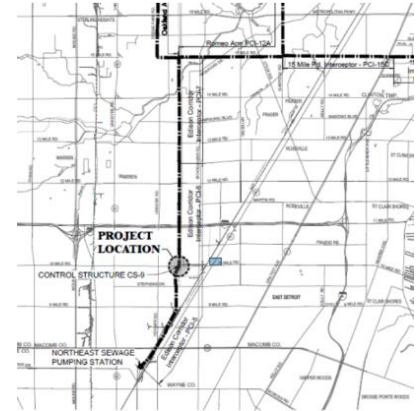

**CS-9 Project location**

### Summary of OMID Design and Construction Status:

Work In Construction Since 2009							
Seg. No	Contract No. (Description)	Contractor	Const. Comp?	As-Builts Final?	Balancing Change Order?	Contractor Closed Out?	Easements Settled?
1	Contract 1 (CS-9, 5, 3)	Ric-Man	Y	Y	Y	Y	Y
1	Contract 2 (CS-6, 7, 8)	Ric-Man	Y	Y	Y	Y	Y
2	Contract 3-2E (Gatehouse)	IWPC (Weiss)	Y	Y	Y*	Y	N/A
2	Contract 3 (Grouting PCI-5 thru 8)	IWPC	Y	Y	Y	Y	Y
3	Contract 4 (Lining PCI-5 thru 8)	Jay Dee Cont.	Y	Y	Y	Y	Y
4	Contract 5 (Lining PCI-9, 10A/B)	Lanzo	Y	Y	Y	Y	N
4	Contract 6 (Lining PCI-11A)	Lanzo	Y	Y	Y	Y	Y
N/A	Contract 7 (Lining 110' of NIEA)	IWPC	Y	Y	Y	Y	N/A
N/A	Odor/Corrosion Control System	CSM	Y	Y	Y	Y	N/A
N/A	Control Structure Modifications	CSM/Hesco/MCE	Y/Y/Y	Y/Y/N	Y/N/N	Y/N/N	N/A
N/A	OMID Maintenance Repairs	Doetsch	Y	N	N	N	N/A
N/A	CS-9 Gate Modifications	Walsh as CMR	Y	N	N	N	Y
N/A	NESPS Pump & Electrical Upgrade	ASI; Walsh as CMAR	N	N	N	N	Y
N/A	NIEA-OMIDDD Contract 1 (PCI-4)	Marra	N	N	N	N	N

\* In process with Coating Issues Resolution and Change Order and Memo of Understanding approvals in review

# April 20, 2022 OMIDDD Board Meeting

Work Currently in Design/Study/Engineering		
Description	Design Consultant	Status
System-wide Odor/Corrosion Study	Jacobs	Study Complete, modifications pending
NESPS & OMID Maintenance & Repairs	Metco	Engineering/Maintenance Ongoing
NIEA-OMIDDD Contract 2 (PCI-18/19)	NTH	Design Complete; pursuing cost sharing w/ GLWA
Emergency Pumping Plan	ASI/FKE	Design Complete; minor field work remains. System successfully tested; Draft Plan to be modified

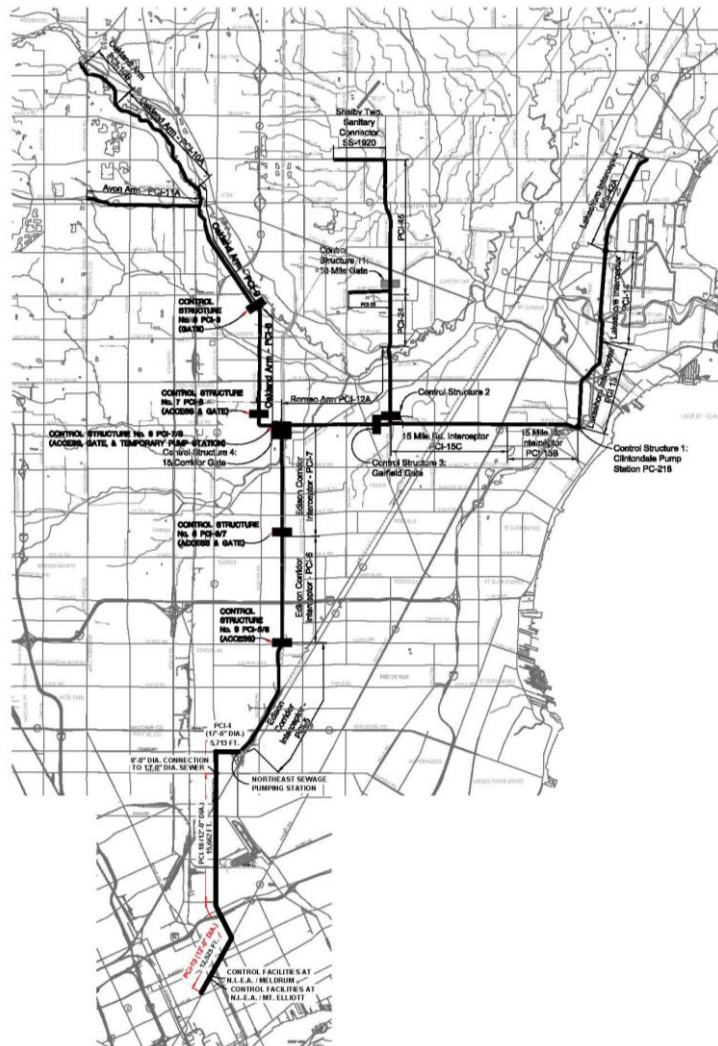

Overview of OMID System in Oakland, Macomb, and Wayne County

# April 20, 2022 OMIDDD Board Meeting

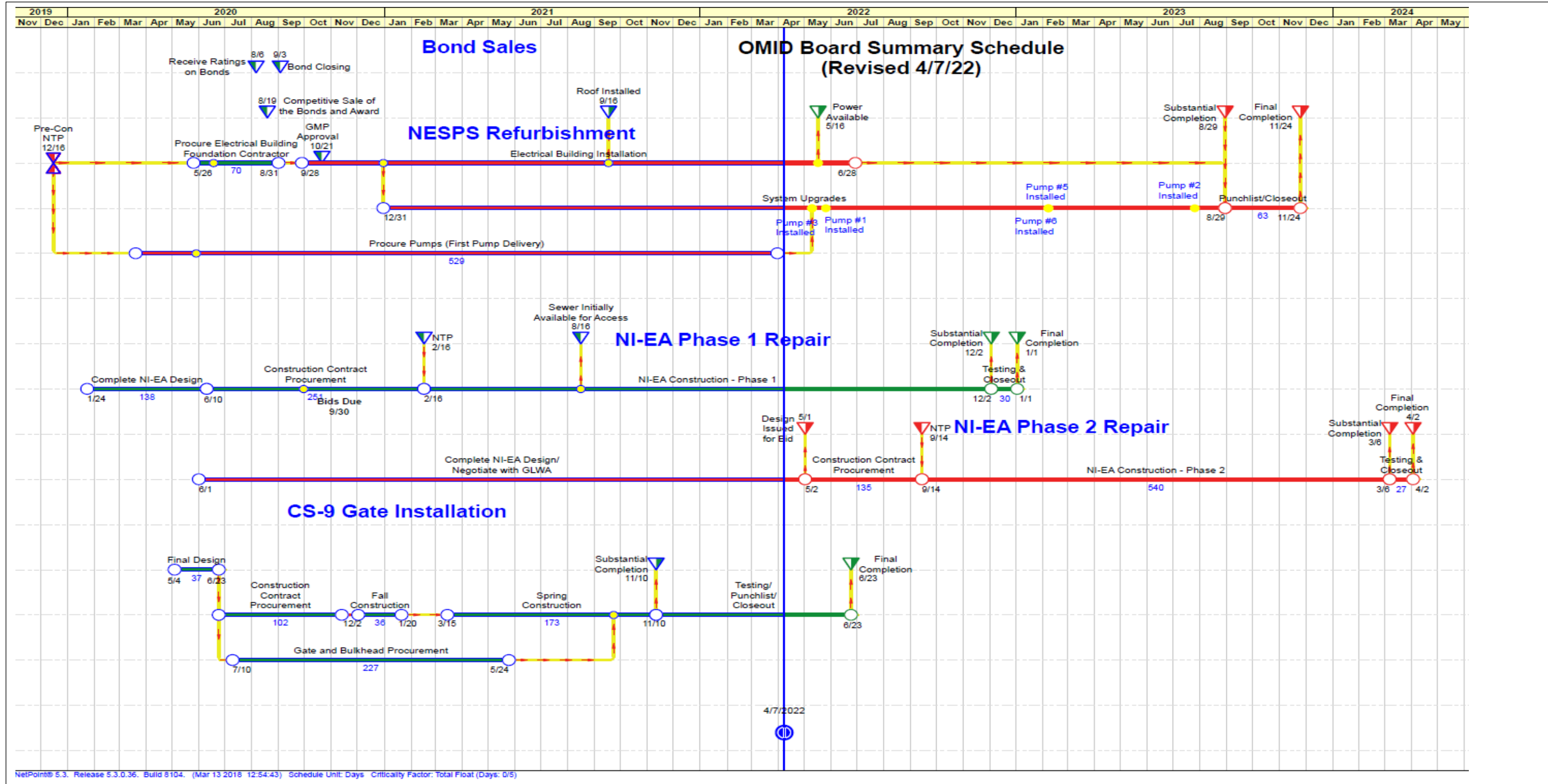

OMID Project Schedule Summary



## April 20, 2022 OMIDDD Board Meeting

### MID/OMID Construction Schedule

Project	Work Location	Owner	Lead Engineer	Contractor	2022												2023												MID/OMID Control Devices Required to Store Flow										Concurrent Work Notes
					A	M	J	J	A	S	O	N	D	J	F	M	A	M	J	J	A	S	O	N	D	CS-2	CS-3	CS-5	CS-6	CS-6 PS	CS-7	CS-8	CS-9	CS-12	CPS				
MID Grouting <small>(Preliminary schedule has GI and LSI work beginning when</small>	Lakeshore Interceptor (LSI)	MID	AEW	Doetsch	/	/	/																		-	-	-	-	-	-	-	n/a	N	Work is Random - If other work requires CS-3 closure, then LSI work will be concurrent. CPS can not be used for storage. Schedule duration is TBD based on grout takes.					
MID Inspection	Routine Inspection of MID Manholes & Interceptors	MID	Fishbeck	Doetsch	/	/	/																			-	-	-	-	-	-	n/a	-	Work may require brief flow control to inspect certain reaches. Work will be coordinated around active construction.					
Segment 6 Lining	15 Mile upstream of Garfield (15 Mile Interceptor)	MID	FKE	Ric-Man	/	/	/	/	/	/	/	/	/	/	/	/	/	/	/	/	/	/	/	/	/	/	/	/	/	/	/	/	Y	Flow control on pause but upcoming. May work concurrent with Segment 5 or NIEA rehabilitation. Schedule is preliminary.					
	15 Mile upstream of Garfield & between CS-2/CS-3 (Romeo Arm)	MID	FKE	Ric-Man	/	/	/	/	/	/	/	/	/	/	/	/	/	/	/	/	/	/	/	/	/	/	Y	Y	N	-	-	-	-	Y	May work concurrent with Segment 5 or NIEA rehabilitation. Flow control conditions at the CS gates is similar with the exception of utilizing CS-2. Schedule is preliminary.				
Segment 5 Lining*	15 Mile between ITC Corridor & Eberlein	MID	FKE	OR	/	/	/	/	/	/	/	/	/	/	/	/	/	/	/	/	/	/	/	/	/	/	/	/	/	/	/	Y	H	If work is concurrent with NIEA rehabilitation; CS-9 is required. Flow control dates may change depending on sediment removal means and methods. Current projected finish is 2 months late.					
NIEA Rehabilitation <small>(Downstream of NESPS)</small>	PCI-4 Shaft & Lining	OMID	NTH	MARRA	/	/	/	/	/	/	/	/	/	/	/	/	/	/	/	/	/	/	/	/	/	/	/	/	/	/	/	-	H	If work is concurrent with Segments 5 & 6 Lining; CS-9 is required.					
	PCI-18/19 Spot Repairs, Lining, and Flow Controls	OMID	NTH	TBD	/	/	/	/	/	/	/	/	/	/	/	/	/	/	/	/	/	/	/	/	/	/	/	/	/	/	/	-	-	Shaft construction. MID/OMID flow control may be required depending on 7-Mile Relief Inter-Connection and PC-663 Gate status. Coordination with GLWA and downstream system when flow is diverted to 7 Mile Relief.					
OMID CCTV Inspection	Throughout System	OMID	NTH	Doetsch	/	/	/	/	/	/	/	/	/	/	/	/	/	/	/	/	/	/	/	/	/	/	/	/	/	/	/	n/a	H	Present work is in upstream manholes so limited flow control necessary. Flow control will be required within certain reaches to facilitate.					
CS-9 Gate Installation & Hobas Repair	CS-9	OMID	NTH	Walsh	/	/	/																		/	/	/	/	/	/	n/a	H	Hobas Repair Moved to Spring.						
NESPS Improvements	NESPS Pump Replacement	OMID	ASI	Walsh	/	/	/	/	/	/	/	/	/	/	/	/	/	/	/	/	/	/	/	/	/	/	/	/	/	/	/	-	H	Will require brief flow control for pump installation, gate installation, and electrical work.					
DB-226 DRI Repairs	GLWA - DRI	GLWA	FKE	Jay Dee	/	/	/	/	/	/	/	/	/	/	/	/	/	/	/	/	/	/	/	/	/	/	/	/	/	/	/	-	-	Can be effected by flows rerouted from the NIEA to the DRI.					
PSPS / COSDS Work <small>(PSPS Shutdown)</small>	PSPS	WRC	n/a	n/a																												-	-	Reduced diversion to PSPS this Fall to SMGD. Scheduled shut down of PSPS in September; no flow diversion to Pontiac WWTP (CRWRRF). Will significantly impact storage capabilities on the Oakland Arm CS gates.					

Table updated on 4/1/2022. Estimates to be updated as necessary.

- \* Flow control will be required for sewer cleaning, currently estimated in 2022. Flow control requirements are TBD based on contractor means & methods, not reflected in "Control Devices Required to Store Flow" section.
- \* Flow control will be required for sewer lining (Schedule TBD). Flow control CS requirements are defined in the "Control Devices Required to Store Flow" section.
- PSPS and ELPS operations can significantly impact storage times upstream of CS-6, 7 & 8 and subsequently downstream control structures. Coordination & alerting for ELPS, PSPS, WRC Meters 1222/1223 & 1000 required.

- Y = Required to store
- N = Required to not store
- H = Helpful to extend work times. *if available when not required for concurrent work.*
- = Irrelevant

- Estimated Project Window
- Flow Control Required
- Flow Control May Be Required

Note CS-6 is currently out of service

Summary of OMID Flow Control Requirements for Ongoing and Future Projects

**Agenda Item No. 10**

Financial Reports – General Financial Report and  
Status of State Revolving Fund Financing and  
Other Financing

YTD Trial Balance

Fund: 84917 Oakland Macomb InterceptorSeg5

As of Fiscal Period: Month 6, 2022

Run By: WRC\_REPORTING

Run: 04/04/2022 at 10:57 AM

Scope: 84917 Oakland Macomb InterceptorSeg5

ACCOUNT		OMID Segment 5 100000003252	OMID NIEA CONSTRUCTION 100000003308	NESPS MECH-ELEC CONSTRUCTION 100000003309	YTD Balance
100100	Cash - Operating	1,426,885.11	12,963,740.21	32,150,870.09	46,541,495.41
104100	Accrued Interest on Investment	(149,773.24)	0.00	0.00	(149,773.24)
151000	Restricted Cash	0.00	3,381,615.00	0.00	3,381,615.00
201210	Vouchers Payable AP Cont	0.00	(181,780.60)	0.00	(181,780.60)
222300	Unearned Revenues	(208,809.66)	(4,224,457.35)	(8,046,142.99)	(12,479,410.00)
	Revenues	415,915.47	0.00	0.00	13,703.68
	Expenditures	0.00	3,177,206.12	4,844,157.65	8,021,363.77
	Special Items- Uses	0.00	0.00	0.00	0.00
381315	FB Restricted Debt	(47,288,433.00)	0.00	0.00	(47,288,433.00)
382100	FB Committed for Capital Proj	45,804,215.32	(15,116,323.38)	(28,948,884.75)	2,141,218.98
		0.00	0.00	0.00	(0.00)

Cash as of 03/31/2022 \$ 46,541,495.41

Invoices/Reimbursements for NIEA Construction on Current Agenda impacting Cash Balance (188,472.93)

Invoices/Reimbursements for NESPS Mech / Electrical Construction on Current Agenda impacting Cash Balance (132,745.00)

Total Net Cash Balance \$ 46,220,277.48

## Water Resources Commissioner

### PROJECT WORK IN PROGRESS

#### OMID NI-EA CONSTRUCTION

**10000003308**

(as of March 31, 2022)

	Budget Amount	Month-to-Date Expenses	Life-to-Date Expenses	LTD Variance
<b>ADM - Administration</b>				
<b>Administration TOTALS</b>				
	584,000.00	0.00	0.00	\$584,000.00
<b>CONT - Contingency</b>				
<b>Contingency TOTALS</b>				
	2,581,000.00	0.00	0.00	\$2,581,000.00
<b>ENG - Engineering</b>				
771638 - Drain Equip Labor		2,603.61	86,659.91	
771639 - Drain Equipment		135.61	3,451.12	
<b>Engineering TOTALS</b>				
	478,000.00	2,739.22	90,111.03	\$387,888.97
<b>ENGCON - Engineering Consultant</b>				
730639 - Engineering Services-Other		0.00	502,022.23	
731444 - Prof Svc-Consultant		0.00	954,190.99	
731472 - Project Construction and Impr		0.00	539,637.75	
<b>Engineering Consultant TOTALS</b>				
	4,913,000.00	0.00	1,995,850.97	\$2,917,149.03
<b>FAC - Facility Acquisition</b>				
730352 - Construction		0.00	2,947,868.47	
731472 - Project Construction and Impr		815,782.44	7,005,055.23	
<b>Facility Acquisition TOTALS</b>				
	17,983,600.00	815,782.44	9,952,923.70	\$8,030,676.30
<b>INS - Inspection</b>				
<b>Inspection TOTALS</b>				
	260,000.00	0.00	0.00	\$260,000.00
<b>LEGAL - Legal and Financial</b>				
730940 - Insurance		0.00	41,250.00	
731073 - Legal Services		5,913.00	49,444.50	
<b>Legal and Financial TOTALS</b>				
	1,259,000.00	5,913.00	90,694.50	\$1,168,305.50
<b>ROW - Right of Way</b>				
730373 - Contracted Services		0.00	3,625.00	
731038 - Land and Easement		0.00	-300.00	
731073 - Legal Services		0.00	17,746.90	
731661 - RW Negotiation and Expense		0.00	5,000.00	
771638 - Drain Equip Labor		258.22	45,153.31	
771639 - Drain Equipment		8.97	1,800.17	
<b>Right of Way TOTALS</b>				
	265,000.00	267.19	73,025.38	\$191,974.62
<b>STD - Standard Operation</b>				
730639 - Engineering Services-Other		0.00	29,419.81	
<b>Standard Operation TOTALS</b>				
	40,000.00	0.00	29,419.81	\$10,580.19
<b>SUR - Survey Crew</b>				

## Water Resources Commissioner

### PROJECT WORK IN PROGRESS

#### OMID NI-EA CONSTRUCTION

**10000003308**

(as of March 31, 2022)

Budget Amount	Month-to-Date Expenses	Life-to-Date Expenses	LTD Variance
<b>Survey Crew TOTALS</b>			
32,000.00	0.00	0.00	\$32,000.00

<b>Project 10000003308 - OMID NI-EA CONSTRUCTION</b>			
<b>Total Project Expenses</b>			
Budget Amount	Month-to-Date Expenses	Life-to-Date Expenses	LTD Variance
\$28,395,600.00	\$824,701.85	\$12,232,025.39	\$16,163,574.61
<b>Total Project Revenue</b>			
Account	Month-to-Date Revenue	Life-to-Date Revenue	
605572-Special Assessments	\$0.00	\$2,206,043.00	
697551-Issuance of Bonds	\$0.00	\$21,965,099.65	
<b>TOTAL REVENUE</b>	<b>\$0.00</b>	<b>\$24,171,142.65</b>	
<b>REVENUE OVER/(UNDER) EXPENSES</b>		<b>\$11,939,117.26</b>	

## Water Resources Commissioner

### PROJECT WORK IN PROGRESS

### NESPS MECH-ELEC CONSTRUCTION

**10000003309**

(as of March 31, 2022)

	Budget Amount	Month-to-Date Expenses	Life-to-Date Expenses	LTD Variance
<b>ADM - Administration</b>				
730940 - Insurance		0.00	44,200.00	
<b>Administration TOTALS</b>				
620,000.00		0.00	44,200.00	\$575,800.00
<b>CONT - Contingency</b>				
<b>Contingency TOTALS</b>				
4,917,000.00		0.00	0.00	\$4,917,000.00
<b>ENG - Engineering</b>				
731346 - Personal Mileage		0.00	352.80	
771638 - Drain Equip Labor		4,900.95	132,480.17	
771639 - Drain Equipment		214.56	5,169.57	
<b>Engineering TOTALS</b>				
446,000.00		5,115.51	138,002.54	\$307,997.46
<b>ENGCON - Engineering Consultant</b>				
730639 - Engineering Services-Other		0.00	1,314,218.36	
731444 - Prof Svc-Consultant		0.00	130,587.68	
731458 - Professional Services		0.00	94,603.44	
<b>Engineering Consultant TOTALS</b>				
3,987,000.00		0.00	1,539,409.48	\$2,447,590.52
<b>FAC - Facility Acquisition</b>				
731472 - Project Construction and Impr		99,820.91	19,605,360.63	
<b>Facility Acquisition TOTALS</b>				
40,857,000.00		99,820.91	19,605,360.63	\$21,251,639.37
<b>INS - Inspection</b>				
731458 - Professional Services		0.00	532.00	
771638 - Drain Equip Labor		13,473.30	248,649.02	
771639 - Drain Equipment		1,555.34	29,406.24	
<b>Inspection TOTALS</b>				
285,000.00		15,028.64	278,587.26	\$6,412.74
<b>LEGAL - Legal and Financial</b>				
730940 - Insurance		0.00	179,800.00	
<b>Legal and Financial TOTALS</b>				
2,417,000.00		0.00	179,800.00	\$2,237,200.00
<b>ROW - Right of Way</b>				
<b>Right of Way TOTALS</b>				
393,000.00		0.00	0.00	\$393,000.00
<b>STD - Standard Operation</b>				
730940 - Insurance		0.00	149,770.00	
<b>Standard Operation TOTALS</b>				
130,000.00		0.00	149,770.00	(\$19,770.00)
<b>SUR - Survey Crew</b>				
<b>Survey Crew TOTALS</b>				
34,000.00		0.00	0.00	\$34,000.00

## Water Resources Commissioner

### PROJECT WORK IN PROGRESS

### NESPS MECH-ELEC CONSTRUCTION

**10000003309**

(as of March 31, 2022)

Budget Amount	Month-to-Date Expenses	Life-to-Date Expenses	LTD Variance
<b>Project 10000003309 - NESPS MECH-ELEC CONSTRUCTION</b>			
<b>Total Project Expenses</b>			
<b>Budget Amount</b>	<b>Month-to-Date Expenses</b>	<b>Life-to-Date Expenses</b>	<b>LTD Variance</b>
\$54,086,000.00	\$119,965.06	\$21,935,129.91	\$32,150,870.09
<b>Total Project Revenue</b>			
<b>Account</b>	<b>Month-to-Date Revenue</b>	<b>Life-to-Date Revenue</b>	
605572-Special Assessments	\$0.00	\$4,202,235.00	
697551-Issuance of Bonds	\$0.00	\$41,837,622.01	
<b>TOTAL REVENUE</b>	<b>\$0.00</b>	<b>\$46,039,857.01</b>	
<b>REVENUE OVER/(UNDER) EXPENSES</b>		<b>\$24,104,727.10</b>	

## Water Resources Commissioner

### PROJECT WORK IN PROGRESS

#### OMID Segment 5

**10000003252**

(as of March 31, 2022)

Budget Amount	Month-to-Date Expenses	Life-to-Date Expenses	LTD Variance
---------------	------------------------	-----------------------	--------------

**ADM - Administration**

730177 - Bond Issuing Cost	0.00	242,201.57
----------------------------	------	------------

<b>Administration TOTALS</b>	0.00	242,201.57	(\$242,201.57)
------------------------------	------	------------	----------------

**LEGAL - Legal and Financial**

730177 - Bond Issuing Cost	0.00	514,935.00
----------------------------	------	------------

<b>Legal and Financial TOTALS</b>	0.00	514,935.00	(\$514,935.00)
-----------------------------------	------	------------	----------------

### Project 10000003252 - OMID Segment 5

**Total Project Expenses**

Budget Amount	Month-to-Date Expenses	Life-to-Date Expenses	LTD Variance
\$0.00	\$0.00	\$757,136.57	(\$757,136.57)

**Total Project Revenue**

Account	Month-to-Date Revenue	Life-to-Date Revenue	
605572-Special Assessments	\$0.00	\$108,835.74	
655077-Accrued Interest Adjustments	\$14,330.98	(\$149,773.24)	
655385-Income from Investments	\$5,726.87	\$781,373.19	
697219-Premiums on Bonds Sold	\$0.00	\$7,672,724.75	
697551-Issuance of Bonds	\$0.00	(\$6,587,721.66)	
<b>TOTAL REVENUE</b>	<b>\$20,057.85</b>	<b>\$1,825,438.78</b>	
<b>REVENUE OVER/(UNDER) EXPENSES</b>		<b>\$1,068,302.21</b>	



Oakland County - Water Resources Commissioner's Office  
Fund Equity: Schedule of Reserves and Dedicated Funds  
As of Date: March 31 2022

Fund	Description	Major Maintenance	Emergency Maintenance	Capital Improvement	Undesignated	Committed for Capital Projects	Total Equity
82912	OMIDD Maintenance Fund	3,275,151.30	3,000,000.00	2,817,170.89	5,715,041.88		14,807,364.07
84915	OMIDD Seg 4						
	- Project 1-1913 Interceptor Seg 4					42,295.44	42,295.44
84915	OMIDD Seg 5						
	- Project 1-3252 Interceptor Seg 5 Bond Issue					1,068,302.21	
	- Project 1-3308 NESPS Mech / Elect Const					11,939,117.26	
	- Project 1-3309 NI-EA Construction					24,104,727.10	37,112,146.57
Total Equity in Maintenance and Construction Funds							<u>51,961,806.08</u>

**NOTE: This report presents pre-closing figures and as such are subject to change**

**County of Oakland  
OMIDD Maintenance Fund  
Statement of Net Position  
March 31, 2022**

**ASSETS**

Current assets:

Cash	\$ 21,869,899.72
Accrued interest receivable	88,344.69
Due from municipalities	4,259,286.67
Due from other funds	500.00
Prepaid Expenses	703,676.99

Total assets \$ 26,921,708.07

**LIABILITIES**

Current liabilities:

Vouchers payable	6,132,721.23
Accounts Payable	85,000.00
Due To Municipalities	5,892,204.40
Due To Primary Government	168.37
Deposits	4,250.00

Total liabilities \$ 12,114,344.00

**NET POSITION**

FB Major Maint Reserve	3,275,151.30
FB Capital Improvement Reserve	2,817,170.89
FB Restricted Programs	5,715,041.88
FB Emergency Maint Reserve	3,000,000.00
Total net position	<u>\$ 14,807,364.07</u>

**NOTE: This report presents pre-closing figures and as such  
are subject to change**

**County of Oakland**  
**Oakland Macomb InterceptorCh21 Fund**  
**Statement of Revenues, Expenses, and Changes in Net Position**  
**For the Six Months Ended March 31, 2022**  
**50% of The Year Complete**

	<u>Amended Budget</u>	<u>Actual</u>	<u>(Unfavorable) Variance</u>	<u>TYD % of Budget</u>
<b>Operating revenues</b>				
Sewage Disposal Services	75,350,030.00	37,675,015.02	(37,675,014.98)	50.00%
Inspection Fees	170.00	0.00	\$ (170.00)	0.00%
Plan Review Fees	250.00	0.00	(250.00)	0.00%
Prior Years Adjustments	0.00	187.50	187.50	No Budget
Total operating revenue:	<u>75,350,450.00</u>	<u>37,675,202.52</u>	<u>(37,675,014.98)</u>	<u>50.00%</u>
<b>Operating expenses</b>				
Salaries	0.00	0.00	0.00	No Budget
Fringe benefits	0.00	0.00	0.00	No Budget
<b>Contractual services</b>				
Contracted Services	10,023,300.00	807,139.18	\$ 9,216,160.82	8.05%
Electrical Service	806,340.00	507,737.57	298,602.43	62.97%
Engineering Services-Other	41,390.00	30,282.55	11,107.45	73.16%
Equipment Maintenance	665,000.00	148,705.76	516,294.24	22.36%
Equipment Repair	416,830.00	612,940.01	(196,110.01)	147.05%
Insurance	804,110.00	142,023.45	662,086.55	17.66%
Legal Services	68,080.00	6,656.00	61,424.00	9.78%
Licenses and Permits	0.00	420.00	(420.00)	No Budget
Natural Gas	80,000.00	8,419.12	71,580.88	10.52%
Prof Svc-Consultant	0.00	77,390.00	(77,390.00)	No Budget
Professional Services	0.00	8,176.85	(8,176.85)	No Budget
Project Construction and Impr	0.00	30,000.00	(30,000.00)	No Budget
Public Services	25,000.00	19,485.48	5,514.52	77.94%
Sewage Disposal Services	69,709,800.00	34,854,949.98	34,854,850.02	50.00%
Testing Services	0.00	1,940.11	(1,940.11)	No Budget
Water and Sewage Charges	150,000.00	48,672.41	101,327.59	32.45%
Workshops and Meeting	1,500.00	168.37	1,331.63	11.22%
Total contractual services	<u>82,791,350.00</u>	<u>37,305,106.84</u>	<u>45,486,243.16</u>	<u>45.06%</u>
<b>Commodities</b>				
Material and Supplies	8,000.00	0.00	8,000.00	0.00%
Total commodities	<u>8,000.00</u>	<u>0.00</u>	<u>8,000.00</u>	<u>0.00%</u>
<b>Depreciation</b>				
Total depreciation				
<b>Internal services</b>				
Drain Equip Materials	840.00	0.00	\$ 840.00	0.00%
Drain Equip Labor	59,100.00	53,519.32	5,580.68	90.56%
Drain Equipment	1,260.00	2,266.95	(1,006.95)	179.92%
Total internal services	<u>61,200.00</u>	<u>55,786.27</u>	<u>5,413.73</u>	<u>91.15%</u>
Total operating expense	<u>82,860,550.00</u>	<u>37,360,893.11</u>	<u>45,499,656.89</u>	<u>45.09%</u>
Operating income (loss)	<u>(7,510,100.00)</u>	<u>314,309.41</u>	<u>7,824,409.41</u>	<u>-4.19%</u>
<b>Nonoperating revenues (expenses)</b>				
Income from investments	200,000.00	85,534.23	(114,465.77)	42.77%
Insurance Recoveries	0.00	5,626.00	5,626.00	No Budget
Total nonoperating revenues (expenses)	<u>200,000.00</u>	<u>91,160.23</u>	<u>(108,839.77)</u>	<u>45.58%</u>
Income (loss) before transfer	<u>(7,310,100.00)</u>	<u>405,469.64</u>	<u>7,715,569.64</u>	<u>45.58%</u>
Transfers in	0.00	0.00	0.00	No Budget
Transfers out	0.00	0.00	0.00	No Budget
Change in net position	<u>(7,310,100.00)</u>	<u>405,469.64</u>	<u>7,715,569.64</u>	<u>-5.55%</u>
Net Position - beginning		<u>14,401,894.43</u>		
Net Position - ending		<u>14,807,364.07</u>		

**NOTE: This report presents pre-closing figures and as such are subject to change**

**OAKLAND MACOMB INTERCEPTOR DRAINAGE BOARD - APPROVAL OF INVOICES/REIMBURSEMENTS**

OMI DD Meeting Date 4/20/2022

Payable To	Invoice #	84917	84917	82912	Total
		1-3308	1-3309		
		<u>Segment 5 NIEA Construction</u>	<u>Segment 5 NESPS Mech / Electric Construction</u>	<u>Operations &amp; Maintenance</u>	
Oakland County *	WRC Labor/Fringes/Non-direct Labor	2,861.82	18,374.25		\$21,236.07
Oakland County *	WRC Equipment	144.58	1,769.90		\$1,914.48
Applied Science, Inc	Invoice # 38 (ASI Inv. #8088) Services 02/27/22 to 03/26/22		82,095.87		\$82,095.87
CH2M - LG Design	Invoice # 705773CH037 Services 1/29/22 - 4/1/22			3,842.51	\$3,842.51
Clark Hill PLC	Invoice # 1070310 Matter 404547 Services Through 02/28/2021	1,944.00			\$1,944.00
Clark Hill PLC	Invoice # 1091359 Matter 404547 Services Through 04/30/2021	2,079.00			\$2,079.00
Clark Hill PLC	Invoice # 1119387 Matter 404547 Services Through 07/31/2021	2,484.00			\$2,484.00
Clark Hill PLC	Invoice # 1185359 Matter 438991 Services Through 02/28/2022			944.50	\$944.50
Clark Hill PLC	Invoice # 1185477 Matter 404547 Services Through 02/28/2022	2,430.00			\$2,430.00
Clark Hill PLC	Invoice # 1185478 Matter 424741 Services Through 02/28/2022			270.00	\$270.00
Comerica - P Card reimbursement	Panara Bread OMIDD Meeting Catering 3/16/2022			186.65	\$186.65
D'Angelo Brothers Inc.	Invoice # 8213-OMID 11010 E State Fair St. Pump Station Hydrant 3/6/22			13,115.00	\$13,115.00
Dickinson Wright PLLC	Invoice # 1671430 Matter 012840-00436 Service through 02/28/2022			118.50	\$118.50
HESCO	Invoice # 2213496 OMIDD CS-8 Preventative Maintenance 03/07/2022			2,742.25	\$2,742.25
HESCO	Invoice # 2213521 Preassure Filter CS-5 03/21/2022			430.00	\$430.00
Meadowbrook Insurance Agency	Invoice # 84958 3rd Quarterly Installment 3/8/2022		47,950.43		\$47,950.43
METCO	Invoice # 1811-39 Through 04/03/22			88,289.98	\$88,289.98
Motor City Electric Technologies	Invoice # 36819 OMIDD Sanitary Pump Station SCADA Dated 11/30/21	10,200.00			\$10,200.00
Motor City Electric Technologies	Invoice # 93699 NESP SCADA Cut Over Service Date 06/01/21			315.00	\$315.00
Motor City Electric Technologies	Invoice # 93730 NESP SCADA Cut Over Service Date 05/19/21			154.00	\$154.00
Motor City Electric Technologies	Invoice # 93731 NESP SCADA Cut Over Service Date 06/05/21			216.00	\$216.00
Motor City Electric Technologies	Invoice # 93732 NESP SCADA Cut Over Service Date 06/12/21			3,096.00	\$3,096.00
Motor City Electric Technologies	Invoice # 93733 NESP SCADA Cut Over Service Date 06/25/21			180.00	\$180.00
Motor City Electric Technologies	Invoice # 93767 NESP SCADA Cut Over Service Date 07/15/21			495.00	\$495.00
Motor City Electric Technologies	Invoice # 93768 NESP SCADA Cut Over Service Date 02/08/21			4,620.00	\$4,620.00
Motor City Electric Technologies	Invoice # 93770 NESP SCADA Cut Over Service Date 06/30/21			90.00	\$90.00
Motor City Electric Technologies	Invoice # 93799 NESP SCADA Cut Over Service Date 07/07/21			180.00	\$180.00
Motor City Electric Technologies	Invoice # 93803 NESP SCADA Cut Over Service Date 06/30/21			90.00	\$90.00
Motor City Electric Technologies	Invoice # 94071 NESP SCADA Cut Over Service Date 11/14/21			846.00	\$846.00
Motor City Electric Technologies	Invoice # 94072 NESP SCADA Cut Over Service Date 11/05/21			315.00	\$315.00
Motor City Electric Technologies	Invoice # 94073 NESP SCADA Cut Over Service Date 11/10/21			180.00	\$180.00
Motor City Electric Technologies	Invoice # 94153 NESP SCADA Cut Over Service Date 12/17/21			180.00	\$180.00
Motor City Electric Technologies	Invoice # 94244 NESP SCADA Cut Over Service Date 01/21/22			90.00	\$90.00
Motor City Electric Technologies	Invoice # 94245 NESP SCADA Cut Over Service Date 01/03/22			45.00	\$45.00
Motor City Electric Technologies	Invoice # 94321 NESP SCADA Cut Over Service Date 01/24/22			90.00	\$90.00
Motor City Electric Technologies	Invoice # 94388 NESP SCADA Cut Over Service Date 03/29/22			180.00	\$180.00
Motor City Electric Technologies	Invoice # 94389 NESP SCADA Cut Over Service Date 04/04/22			810.90	\$810.90
NTH Consultants	Inv # 03 For NESPS Supplementary Support Service Through 03/25/2022			9,794.91	\$9,794.91
NTH Consultants	Inv # 08 For 2021 OMIDD System Inspection Service Through 03/25/2022			3,806.31	\$3,806.31
NTH Consultants	Inv # 16 NI-EA Construction Engineering Service (D-425) Through 03/25/2022	128,408.46			\$128,408.46
NTH Consultants	Inv # 16 NI-EA Construction Engineering Service (D-421) Through 03/25/2022		2,698.70		\$2,698.70
NTH Consultants	Inv # 34 - OMIDD NI-EA Rehab Services Through 03/25/2022	12,079.69			\$12,079.69
NTH Consultants	Inv # 63 - OMIDD NESPS Discharge Chamber Service Through 03/25/2022			5,053.64	\$5,053.64
PM Technologies	Invoice # 0000155094 NESPS Generator 1 repair 07/23/21			643.45	\$643.45
PM Technologies	Invoice # 0000155221 NESPS Generator 1 repair 06/09/21			817.50	\$817.50
PM Technologies	Invoice # 0000157506 NESPS AST's Inspection 06/16/21			1,000.00	\$1,000.00
PMA Consultants	Invoice # 03559.01 - 21 Professional Services Through 02/28/22	16,484.45			\$16,484.45
PMA Consultants	Invoice # 03559.01 - 22 Professional Services Through 03/31/22	12,363.33			\$12,363.33
Rotor Electric Company	Invoice # 12489 Pump 4, Pump 5, and Pump 6 Maintenance 01/12/22			5,325.98	\$5,325.98
Rotor Electric Company	Invoice # 12490 Minor Repairs 02/11/22			3,067.30	\$3,067.30
Rotor Electric Company	Invoice # 12491 Energizing and Loading 01/27/22			2,775.00	\$2,775.00
Rotor Electric Company	Invoice # 12492 P2 1/21/22 Trip Event 01/25/22			15,201.05	\$15,201.05
Rotor Electric Company	Invoice # 12493 Pump 5 Emergency 03/22/22			994.00	\$994.00
Rotor Electric Company	Invoice # 12494 Pump 6 Emergency 03/04/22			994.00	\$994.00
Rotor Electric Company	Invoice # 12495 Intigration Into SCADA 02/03/22			4,314.98	\$4,314.98
Rotor Electric Company	Invoice # 12496 P2 Shelter HVAC Circuits 03/10/22			4,628.11	\$4,628.11
Rotor Electric Company	Invoice # 12497 P2 1/21/22 Trip Event 01/24/22			10,155.01	\$10,155.01
	<b>Total Invoices/Reimbursements for Approval</b>	<b>\$191,479.33</b>	<b>\$152,889.15</b>	<b>\$190,683.53</b>	<b>\$535,052.01</b>
	* Less WRC Charges already paid from OMI Fund	<b>(3,006.40)</b>	<b>(20,144.15)</b>	<b>0.00</b>	<b>(23,150.55)</b>
	<b>Total Invoices/Reimbursements that will impact Cash Balance listed on Current Trial Balance submitted to OMI Drain Board</b>	<b>\$188,472.93</b>	<b>\$132,745.00</b>	<b>\$190,683.53</b>	<b>\$511,901.46</b>

## **Agenda Item No. 11**

### **Invoices**

OMI Segment 5 NESP Mech - Elect Construction Project - WRC Labor/Fringes/Non-Direct Labor Factor for Trans Dates - 02/26/2022 - 3/25/2022									
WOID	Date Entered	Date Worked	Name/Description	Hours/Units	Cost	Cost Category	Assign Equipment	Project	Activity
984656	02/28/22	02/14/22	BROWN, JOEL	1.50	188.18	REGULAR	WRCCON	100000003309	ENG
984656	02/28/22	02/15/22	BROWN, JOEL	2.00	250.90	REGULAR	WRCCON	100000003309	ENG
984656	02/28/22	02/16/22	BROWN, JOEL	2.00	250.90	REGULAR	WRCCON	100000003309	ENG
984656	02/28/22	02/17/22	BROWN, JOEL	7.00	878.15	REGULAR	WRCCON	100000003309	ENG
984656	02/28/22	02/18/22	BROWN, JOEL	1.50	188.18	REGULAR	WRCCON	100000003309	ENG
984656	02/28/22	02/23/22	BROWN, JOEL	1.00	125.45	REGULAR	WRCCON	100000003309	ENG
984656	02/28/22	02/24/22	BROWN, JOEL	1.50	188.18	REGULAR	WRCCON	100000003309	ENG
984656	02/28/22	02/25/22	BROWN, JOEL	3.00	376.35	REGULAR	WRCCON	100000003309	ENG
			<b>BROWN, JOEL Total</b>		<b>2,446.29</b>				
1050210	03/04/22	03/04/22	CARLEY, JOSEPH	1.00	81.65	REGULAR	WRCCDM	100000003309	INS
1050210	03/09/22	03/08/22	CARLEY, JOSEPH	1.00	81.65	REGULAR	WRCCDM	100000003309	INS
1050210	03/11/22	03/11/22	CARLEY, JOSEPH	1.00	81.65	REGULAR	WRCCDM	100000003309	INS
1050210	03/17/22	03/17/22	CARLEY, JOSEPH	4.50	367.43	REGULAR	WRCCDM	100000003309	INS
1050210	03/18/22	03/18/22	CARLEY, JOSEPH	2.00	163.30	REGULAR	WRCCDM	100000003309	INS
1050210	03/25/22	03/24/22	CARLEY, JOSEPH	2.00	163.30	REGULAR	WRCCDM	100000003309	INS
			<b>CARLEY, JOSEPH Total</b>		<b>938.98</b>				
984656	03/10/22	02/15/22	LOCKHART, SIDNEY	3.00	409.11	REGULAR	WRCADM	100000003309	ENG
984656	03/11/22	02/28/22	LOCKHART, SIDNEY	2.00	272.74	REGULAR	WRCADM	100000003309	ENG
984656	03/11/22	03/01/22	LOCKHART, SIDNEY	2.00	272.74	REGULAR	WRCADM	100000003309	ENG
984656	03/11/22	03/02/22	LOCKHART, SIDNEY	2.00	272.74	REGULAR	WRCADM	100000003309	ENG
984656	03/11/22	03/03/22	LOCKHART, SIDNEY	3.00	409.11	REGULAR	WRCADM	100000003309	ENG
984656	03/11/22	03/04/22	LOCKHART, SIDNEY	2.00	272.74	REGULAR	WRCADM	100000003309	ENG
984656	03/11/22	03/07/22	LOCKHART, SIDNEY	2.00	272.74	REGULAR	WRCADM	100000003309	ENG
984656	03/11/22	03/08/22	LOCKHART, SIDNEY	2.00	272.74	REGULAR	WRCADM	100000003309	ENG
			<b>LOCKHART, SIDNEY Total</b>		<b>2,454.66</b>				
1050210	02/28/22	02/28/22	ROBERTS, PATRICK	8.00	564.24	REGULAR	WRCCDM	100000003309	INS
1050210	02/28/22	02/28/22	ROBERTS, PATRICK	1.00	82.00	OVERTIME	WRCCDM	100000003309	INS
1050210	03/01/22	03/01/22	ROBERTS, PATRICK	8.00	564.24	REGULAR	WRCCDM	100000003309	INS
1050210	03/01/22	03/01/22	ROBERTS, PATRICK	1.00	82.00	OVERTIME	WRCCDM	100000003309	INS
1050210	03/02/22	03/02/22	ROBERTS, PATRICK	8.00	564.24	REGULAR	WRCCDM	100000003309	INS
1050210	03/02/22	03/02/22	ROBERTS, PATRICK	1.00	82.00	OVERTIME	WRCCDM	100000003309	INS
1050210	03/03/22	03/03/22	ROBERTS, PATRICK	8.00	564.24	REGULAR	WRCCDM	100000003309	INS
1050210	03/03/22	03/03/22	ROBERTS, PATRICK	2.00	164.00	OVERTIME	WRCCDM	100000003309	INS
1050210	03/04/22	03/04/22	ROBERTS, PATRICK	8.00	564.24	REGULAR	WRCCDM	100000003309	INS
1050210	03/04/22	03/04/22	ROBERTS, PATRICK	2.00	164.00	OVERTIME	WRCCDM	100000003309	INS
1050210	03/07/22	03/07/22	ROBERTS, PATRICK	8.00	564.24	REGULAR	WRCCDM	100000003309	INS
1050210	03/07/22	03/07/22	ROBERTS, PATRICK	1.00	82.00	OVERTIME	WRCCDM	100000003309	INS
1050210	03/08/22	03/08/22	ROBERTS, PATRICK	8.00	564.24	REGULAR	WRCCDM	100000003309	INS
1050210	03/08/22	03/08/22	ROBERTS, PATRICK	2.00	164.00	OVERTIME	WRCCDM	100000003309	INS
1050210	03/09/22	03/09/22	ROBERTS, PATRICK	8.00	564.24	REGULAR	WRCCDM	100000003309	INS
1050210	03/09/22	03/09/22	ROBERTS, PATRICK	1.00	82.00	OVERTIME	WRCCDM	100000003309	INS
1050210	03/10/22	03/10/22	ROBERTS, PATRICK	8.00	564.24	REGULAR	WRCCDM	100000003309	INS
1050210	03/10/22	03/10/22	ROBERTS, PATRICK	2.00	164.00	OVERTIME	WRCCDM	100000003309	INS
1050210	03/11/22	03/11/22	ROBERTS, PATRICK	8.00	564.24	REGULAR	WRCCDM	100000003309	INS
1050210	03/11/22	03/11/22	ROBERTS, PATRICK	1.00	82.00	OVERTIME	WRCCDM	100000003309	INS
1050210	03/14/22	03/14/22	ROBERTS, PATRICK	8.00	564.24	REGULAR	WRCCDM	100000003309	INS
1050210	03/14/22	03/14/22	ROBERTS, PATRICK	1.00	82.00	OVERTIME	WRCCDM	100000003309	INS
1050210	03/15/22	03/15/22	ROBERTS, PATRICK	8.00	564.24	REGULAR	WRCCDM	100000003309	INS
1050210	03/15/22	03/15/22	ROBERTS, PATRICK	2.00	164.00	OVERTIME	WRCCDM	100000003309	INS
1050210	03/16/22	03/16/22	ROBERTS, PATRICK	8.00	564.24	REGULAR	WRCCDM	100000003309	INS
1050210	03/16/22	03/16/22	ROBERTS, PATRICK	8.00	656.00	OVERTIME	WRCCDM	100000003309	INS
1050210	03/21/22	03/21/22	ROBERTS, PATRICK	8.00	564.24	REGULAR	WRCCDM	100000003309	INS
1050210	03/22/22	03/22/22	ROBERTS, PATRICK	8.00	564.24	REGULAR	WRCCDM	100000003309	INS
1050210	03/22/22	03/22/22	ROBERTS, PATRICK	1.00	82.00	OVERTIME	WRCCDM	100000003309	INS
1050210	03/23/22	03/23/22	ROBERTS, PATRICK	8.00	564.24	REGULAR	WRCCDM	100000003309	INS
1050210	03/23/22	03/23/22	ROBERTS, PATRICK	1.00	82.00	OVERTIME	WRCCDM	100000003309	INS
1050210	03/24/22	03/24/22	ROBERTS, PATRICK	8.00	564.24	REGULAR	WRCCDM	100000003309	INS
1050210	03/24/22	03/24/22	ROBERTS, PATRICK	1.00	82.00	OVERTIME	WRCCDM	100000003309	INS
1050210	03/25/22	03/25/22	ROBERTS, PATRICK	8.00	564.24	REGULAR	WRCCDM	100000003309	INS
1050210	03/25/22	03/25/22	ROBERTS, PATRICK	1.00	82.00	OVERTIME	WRCCDM	100000003309	INS
			<b>ROBERTS, PATRICK Total</b>		<b>12,534.32</b>				
			<b>Grand Total</b>		<b>18,374.25</b>				

OMI Segment 5 NESP Mech - Elect Construction Project - WRC Labor/Fringes/Non-Direct Labor Factor for Trans Dates - 2/26/2022 - 3/25/2022									
WOID	Date Entered	Date Worked	Name/Description	Hours/Units	Cost	Cost Category	Assign Equipment	Project	Activity
984656	02/28/22	02/14/22	BROWN, JOEL	1.50	0.60	ASSIGNED	Cell Phone	10000003309	ENG
984656	02/28/22	02/14/22	BROWN, JOEL	1.50	3.51	ASSIGNED	PC/Computer	10000003309	ENG
984656	02/28/22	02/14/22	BROWN, JOEL	1.50	0.38	ASSIGNED	Tablet/iPad	10000003309	ENG
984656	02/28/22	02/15/22	BROWN, JOEL	2.00	0.80	ASSIGNED	Cell Phone	10000003309	ENG
984656	02/28/22	02/15/22	BROWN, JOEL	2.00	4.68	ASSIGNED	PC/Computer	10000003309	ENG
984656	02/28/22	02/15/22	BROWN, JOEL	2.00	0.50	ASSIGNED	Tablet/iPad	10000003309	ENG
984656	02/28/22	02/16/22	BROWN, JOEL	2.00	0.80	ASSIGNED	Cell Phone	10000003309	ENG
984656	02/28/22	02/16/22	BROWN, JOEL	2.00	4.68	ASSIGNED	PC/Computer	10000003309	ENG
984656	02/28/22	02/16/22	BROWN, JOEL	2.00	0.50	ASSIGNED	Tablet/iPad	10000003309	ENG
984656	02/28/22	02/17/22	BROWN, JOEL	7.00	2.80	ASSIGNED	Cell Phone	10000003309	ENG
984656	02/28/22	02/17/22	BROWN, JOEL	7.00	16.38	ASSIGNED	PC/Computer	10000003309	ENG
984656	02/28/22	02/17/22	BROWN, JOEL	7.00	1.75	ASSIGNED	Tablet/iPad	10000003309	ENG
984656	02/28/22	02/18/22	BROWN, JOEL	1.50	0.60	ASSIGNED	Cell Phone	10000003309	ENG
984656	02/28/22	02/18/22	BROWN, JOEL	1.50	3.51	ASSIGNED	PC/Computer	10000003309	ENG
984656	02/28/22	02/18/22	BROWN, JOEL	1.50	0.38	ASSIGNED	Tablet/iPad	10000003309	ENG
984656	02/28/22	02/23/22	BROWN, JOEL	1.00	0.40	ASSIGNED	Cell Phone	10000003309	ENG
984656	02/28/22	02/23/22	BROWN, JOEL	1.00	2.34	ASSIGNED	PC/Computer	10000003309	ENG
984656	02/28/22	02/23/22	BROWN, JOEL	1.00	0.25	ASSIGNED	Tablet/iPad	10000003309	ENG
984656	02/28/22	02/24/22	BROWN, JOEL	1.50	0.60	ASSIGNED	Cell Phone	10000003309	ENG
984656	02/28/22	02/24/22	BROWN, JOEL	1.50	3.51	ASSIGNED	PC/Computer	10000003309	ENG
984656	02/28/22	02/24/22	BROWN, JOEL	1.50	0.38	ASSIGNED	Tablet/iPad	10000003309	ENG
984656	02/28/22	02/25/22	BROWN, JOEL	3.00	1.20	ASSIGNED	Cell Phone	10000003309	ENG
984656	02/28/22	02/25/22	BROWN, JOEL	3.00	7.02	ASSIGNED	PC/Computer	10000003309	ENG
984656	02/28/22	02/25/22	BROWN, JOEL	3.00	0.75	ASSIGNED	Tablet/iPad	10000003309	ENG
			<b>BROWN, JOEL Total</b>		<b>58.32</b>				
1050210	03/04/22	03/04/22	CARLEY, JOSEPH	1.00	5.69	ASSIGNED	3/4 Ton Pick-up	10000003309	INS
1050210	03/04/22	03/04/22	CARLEY, JOSEPH	1.00	0.40	ASSIGNED	Cell Phone	10000003309	INS
1050210	03/04/22	03/04/22	CARLEY, JOSEPH	1.00	2.34	ASSIGNED	PC/Computer	10000003309	INS
1050210	03/09/22	03/08/22	CARLEY, JOSEPH	1.00	5.69	ASSIGNED	3/4 Ton Pick-up	10000003309	INS
1050210	03/09/22	03/08/22	CARLEY, JOSEPH	1.00	0.40	ASSIGNED	Cell Phone	10000003309	INS
1050210	03/09/22	03/08/22	CARLEY, JOSEPH	1.00	2.34	ASSIGNED	PC/Computer	10000003309	INS
1050210	03/11/22	03/11/22	CARLEY, JOSEPH	1.00	5.69	ASSIGNED	3/4 Ton Pick-up	10000003309	INS
1050210	03/11/22	03/11/22	CARLEY, JOSEPH	1.00	0.40	ASSIGNED	Cell Phone	10000003309	INS
1050210	03/11/22	03/11/22	CARLEY, JOSEPH	1.00	2.34	ASSIGNED	PC/Computer	10000003309	INS
1050210	03/17/22	03/17/22	CARLEY, JOSEPH	4.50	25.61	ASSIGNED	3/4 Ton Pick-up	10000003309	INS
1050210	03/17/22	03/17/22	CARLEY, JOSEPH	4.50	1.80	ASSIGNED	Cell Phone	10000003309	INS
1050210	03/17/22	03/17/22	CARLEY, JOSEPH	4.50	10.53	ASSIGNED	PC/Computer	10000003309	INS
1050210	03/18/22	03/18/22	CARLEY, JOSEPH	2.00	11.38	ASSIGNED	3/4 Ton Pick-up	10000003309	INS
1050210	03/18/22	03/18/22	CARLEY, JOSEPH	2.00	0.80	ASSIGNED	Cell Phone	10000003309	INS
1050210	03/18/22	03/18/22	CARLEY, JOSEPH	2.00	4.68	ASSIGNED	PC/Computer	10000003309	INS
1050210	03/25/22	03/24/22	CARLEY, JOSEPH	2.00	11.38	ASSIGNED	3/4 Ton Pick-up	10000003309	INS
1050210	03/25/22	03/24/22	CARLEY, JOSEPH	2.00	0.80	ASSIGNED	Cell Phone	10000003309	INS
1050210	03/25/22	03/24/22	CARLEY, JOSEPH	2.00	4.68	ASSIGNED	PC/Computer	10000003309	INS
			<b>CARLEY, JOSEPH Total</b>		<b>96.95</b>				
984656	03/10/22	02/15/22	LOCKHART, SIDNEY	3.00	17.07	ASSIGNED	Blazer/Suburbans	10000003309	ENG
984656	03/10/22	02/15/22	LOCKHART, SIDNEY	3.00	1.20	ASSIGNED	Cell Phone	10000003309	ENG
984656	03/10/22	02/15/22	LOCKHART, SIDNEY	3.00	7.02	ASSIGNED	PC/Computer	10000003309	ENG
984656	03/10/22	02/15/22	LOCKHART, SIDNEY	3.00	0.75	ASSIGNED	Tablet/iPad	10000003309	ENG
984656	03/11/22	02/28/22	LOCKHART, SIDNEY	2.00	11.38	ASSIGNED	Blazer/Suburbans	10000003309	ENG
984656	03/11/22	02/28/22	LOCKHART, SIDNEY	2.00	0.80	ASSIGNED	Cell Phone	10000003309	ENG
984656	03/11/22	02/28/22	LOCKHART, SIDNEY	2.00	4.68	ASSIGNED	PC/Computer	10000003309	ENG
984656	03/11/22	02/28/22	LOCKHART, SIDNEY	2.00	0.50	ASSIGNED	Tablet/iPad	10000003309	ENG
984656	03/11/22	03/01/22	LOCKHART, SIDNEY	2.00	11.38	ASSIGNED	Blazer/Suburbans	10000003309	ENG
984656	03/11/22	03/01/22	LOCKHART, SIDNEY	2.00	0.80	ASSIGNED	Cell Phone	10000003309	ENG
984656	03/11/22	03/01/22	LOCKHART, SIDNEY	2.00	4.68	ASSIGNED	PC/Computer	10000003309	ENG
984656	03/11/22	03/01/22	LOCKHART, SIDNEY	2.00	0.50	ASSIGNED	Tablet/iPad	10000003309	ENG
984656	03/11/22	03/02/22	LOCKHART, SIDNEY	2.00	11.38	ASSIGNED	Blazer/Suburbans	10000003309	ENG
984656	03/11/22	03/02/22	LOCKHART, SIDNEY	2.00	0.80	ASSIGNED	Cell Phone	10000003309	ENG
984656	03/11/22	03/02/22	LOCKHART, SIDNEY	2.00	4.68	ASSIGNED	PC/Computer	10000003309	ENG
984656	03/11/22	03/02/22	LOCKHART, SIDNEY	2.00	0.50	ASSIGNED	Tablet/iPad	10000003309	ENG
984656	03/11/22	03/03/22	LOCKHART, SIDNEY	3.00	17.07	ASSIGNED	Blazer/Suburbans	10000003309	ENG
984656	03/11/22	03/03/22	LOCKHART, SIDNEY	3.00	1.20	ASSIGNED	Cell Phone	10000003309	ENG
984656	03/11/22	03/03/22	LOCKHART, SIDNEY	3.00	7.02	ASSIGNED	PC/Computer	10000003309	ENG
984656	03/11/22	03/03/22	LOCKHART, SIDNEY	3.00	0.75	ASSIGNED	Tablet/iPad	10000003309	ENG
984656	03/11/22	03/04/22	LOCKHART, SIDNEY	2.00	11.38	ASSIGNED	Blazer/Suburbans	10000003309	ENG
984656	03/11/22	03/04/22	LOCKHART, SIDNEY	2.00	0.80	ASSIGNED	Cell Phone	10000003309	ENG
984656	03/11/22	03/04/22	LOCKHART, SIDNEY	2.00	4.68	ASSIGNED	PC/Computer	10000003309	ENG
984656	03/11/22	03/04/22	LOCKHART, SIDNEY	2.00	0.50	ASSIGNED	Tablet/iPad	10000003309	ENG
984656	03/11/22	03/07/22	LOCKHART, SIDNEY	2.00	11.38	ASSIGNED	Blazer/Suburbans	10000003309	ENG
984656	03/11/22	03/07/22	LOCKHART, SIDNEY	2.00	0.80	ASSIGNED	Cell Phone	10000003309	ENG
984656	03/11/22	03/07/22	LOCKHART, SIDNEY	2.00	4.68	ASSIGNED	PC/Computer	10000003309	ENG





1050210	03/15/22	03/15/22	ROBERTS, PATRICK	2.00	0.80	ASSIGNED	Cell Phone	100000003309	INS
1050210	03/15/22	03/15/22	ROBERTS, PATRICK	8.00	3.20	ASSIGNED	Cell Phone	100000003309	INS
1050210	03/15/22	03/15/22	ROBERTS, PATRICK	2.00	4.68	ASSIGNED	PC/Computer	100000003309	INS
1050210	03/15/22	03/15/22	ROBERTS, PATRICK	8.00	18.72	ASSIGNED	PC/Computer	100000003309	INS
1050210	03/16/22	03/16/22	ROBERTS, PATRICK	8.00	45.52	ASSIGNED	1/2 Ton Pick-up	100000003309	INS
1050210	03/16/22	03/16/22	ROBERTS, PATRICK	8.00	45.52	ASSIGNED	1/2 Ton Pick-up	100000003309	INS
1050210	03/16/22	03/16/22	ROBERTS, PATRICK	8.00	3.20	ASSIGNED	Cell Phone	100000003309	INS
1050210	03/16/22	03/16/22	ROBERTS, PATRICK	8.00	18.72	ASSIGNED	PC/Computer	100000003309	INS
1050210	03/16/22	03/16/22	ROBERTS, PATRICK	8.00	18.72	ASSIGNED	PC/Computer	100000003309	INS
1050210	03/21/22	03/21/22	ROBERTS, PATRICK	8.00	45.52	ASSIGNED	1/2 Ton Pick-up	100000003309	INS
1050210	03/21/22	03/21/22	ROBERTS, PATRICK	8.00	3.20	ASSIGNED	Cell Phone	100000003309	INS
1050210	03/21/22	03/21/22	ROBERTS, PATRICK	8.00	18.72	ASSIGNED	PC/Computer	100000003309	INS
1050210	03/22/22	03/22/22	ROBERTS, PATRICK	1.00	5.69	ASSIGNED	1/2 Ton Pick-up	100000003309	INS
1050210	03/22/22	03/22/22	ROBERTS, PATRICK	8.00	45.52	ASSIGNED	1/2 Ton Pick-up	100000003309	INS
1050210	03/22/22	03/22/22	ROBERTS, PATRICK	1.00	0.40	ASSIGNED	Cell Phone	100000003309	INS
1050210	03/22/22	03/22/22	ROBERTS, PATRICK	8.00	3.20	ASSIGNED	Cell Phone	100000003309	INS
1050210	03/22/22	03/22/22	ROBERTS, PATRICK	1.00	2.34	ASSIGNED	PC/Computer	100000003309	INS
1050210	03/22/22	03/22/22	ROBERTS, PATRICK	8.00	18.72	ASSIGNED	PC/Computer	100000003309	INS
1050210	03/23/22	03/23/22	ROBERTS, PATRICK	1.00	5.69	ASSIGNED	1/2 Ton Pick-up	100000003309	INS
1050210	03/23/22	03/23/22	ROBERTS, PATRICK	8.00	45.52	ASSIGNED	1/2 Ton Pick-up	100000003309	INS
1050210	03/23/22	03/23/22	ROBERTS, PATRICK	1.00	0.40	ASSIGNED	Cell Phone	100000003309	INS
1050210	03/23/22	03/23/22	ROBERTS, PATRICK	8.00	3.20	ASSIGNED	Cell Phone	100000003309	INS
1050210	03/23/22	03/23/22	ROBERTS, PATRICK	1.00	2.34	ASSIGNED	PC/Computer	100000003309	INS
1050210	03/23/22	03/23/22	ROBERTS, PATRICK	8.00	18.72	ASSIGNED	PC/Computer	100000003309	INS
1050210	03/24/22	03/24/22	ROBERTS, PATRICK	1.00	5.69	ASSIGNED	1/2 Ton Pick-up	100000003309	INS
1050210	03/24/22	03/24/22	ROBERTS, PATRICK	8.00	45.52	ASSIGNED	1/2 Ton Pick-up	100000003309	INS
1050210	03/24/22	03/24/22	ROBERTS, PATRICK	1.00	0.40	ASSIGNED	Cell Phone	100000003309	INS
1050210	03/24/22	03/24/22	ROBERTS, PATRICK	8.00	3.20	ASSIGNED	Cell Phone	100000003309	INS
1050210	03/24/22	03/24/22	ROBERTS, PATRICK	1.00	2.34	ASSIGNED	PC/Computer	100000003309	INS
1050210	03/24/22	03/24/22	ROBERTS, PATRICK	8.00	18.72	ASSIGNED	PC/Computer	100000003309	INS
1050210	03/25/22	03/25/22	ROBERTS, PATRICK	8.00	45.52	ASSIGNED	1/2 Ton Pick-up	100000003309	INS
1050210	03/25/22	03/25/22	ROBERTS, PATRICK	1.00	5.69	ASSIGNED	1/2 Ton Pick-up	100000003309	INS
1050210	03/25/22	03/25/22	ROBERTS, PATRICK	1.00	0.40	ASSIGNED	Cell Phone	100000003309	INS
1050210	03/25/22	03/25/22	ROBERTS, PATRICK	8.00	3.20	ASSIGNED	Cell Phone	100000003309	INS
1050210	03/25/22	03/25/22	ROBERTS, PATRICK	8.00	18.72	ASSIGNED	PC/Computer	100000003309	INS
1050210	03/25/22	03/25/22	ROBERTS, PATRICK	1.00	2.34	ASSIGNED	PC/Computer	100000003309	INS
			<b>ROBERTS, PATRICK Total</b>		<b>1,458.39</b>				
			<b>Grand Total</b>		<b>1,769.90</b>				

OMI Segment 5 NI-EA Construction Project - WRC Labor/Fringes/Non-Direct Labor Factor for Trans Dates - 2/26/2022 - 3/25/2022									
WOID	Date Entered	Date Worked	Name/Description	Hours/Units	Cost	Cost Category	Assign Equipment	Project	Activity
984657	2/28/22	2/14/22	BROWN, JOEL	1.50	188.18	REGULAR	WRCCON	100000003308	ENG
984657	2/28/22	2/15/22	BROWN, JOEL	1.00	125.45	REGULAR	WRCCON	100000003308	ENG
984657	2/28/22	2/16/22	BROWN, JOEL	2.00	250.90	REGULAR	WRCCON	100000003308	ENG
984657	2/28/22	2/18/22	BROWN, JOEL	0.50	62.73	REGULAR	WRCCON	100000003308	ENG
984657	2/28/22	2/24/22	BROWN, JOEL	2.00	250.90	REGULAR	WRCCON	100000003308	ENG
			<b>BROWN, JOEL Total</b>		<b>878.16</b>				
984657	3/10/22	2/14/22	LOCKHART, SIDNEY	1.00	136.37	REGULAR	WRCADM	100000003308	ENG
984657	3/10/22	2/15/22	LOCKHART, SIDNEY	1.00	136.37	REGULAR	WRCADM	100000003308	ENG
984657	3/10/22	2/16/22	LOCKHART, SIDNEY	2.00	272.74	REGULAR	WRCADM	100000003308	ENG
984657	3/10/22	2/17/22	LOCKHART, SIDNEY	3.00	409.11	REGULAR	WRCADM	100000003308	ENG
984657	3/10/22	2/25/22	LOCKHART, SIDNEY	2.00	272.74	REGULAR	WRCADM	100000003308	ENG
984657	3/11/22	3/9/22	LOCKHART, SIDNEY	2.00	272.74	REGULAR	WRCADM	100000003308	ENG
984657	3/11/22	3/10/22	LOCKHART, SIDNEY	1.00	136.37	REGULAR	WRCADM	100000003308	ENG
984657	3/11/22	3/11/22	LOCKHART, SIDNEY	2.00	272.74	REGULAR	WRCADM	100000003308	ENG
			<b>LOCKHART, SIDNEY Total</b>		<b>1,909.18</b>				
984657	3/11/22	9/14/21	MAES, LESLI	(2.50)	(183.73)	REGULAR-D	WRCCON	100000003308	ENG
			<b>MAES, LESLI Total</b>		<b>(183.73)</b>				
984662	3/15/22	2/28/22	PARROTT, JEFFREY	1.00	81.65	REGULAR	WRCROW	100000003308	ROW
984662	3/15/22	2/28/22	PARROTT, JEFFREY	1.00	94.92	OVERTIME	WRCROW	100000003308	ROW
984662	3/15/22	3/8/22	PARROTT, JEFFREY	1.00	81.65	REGULAR	WRCROW	100000003308	ROW
			<b>PARROTT, JEFFREY Total</b>		<b>258.22</b>				
			<b>Grand Total</b>		<b>2,861.83</b>				

OMI Segment 5 NI-EA Construction Project - WRC Labor/Fringes/Non-Direct Labor Factor for Trans Dates - 2/26/2022 - 3/25/2022										
WOID	Date Entered	Date Worked	Name/Description	Hours/Units	Cost	Cost Category	Assign Equipment	Project	Activity	
984657	2/28/22	2/14/22	BROWN, JOEL	1.50	0.38	ASSIGNED	Tablet/iPad	100000003308	ENG	
984657	2/28/22	2/14/22	BROWN, JOEL	1.50	0.60	ASSIGNED	Cell Phone	100000003308	ENG	
984657	2/28/22	2/14/22	BROWN, JOEL	1.50	3.51	ASSIGNED	PC/Computer	100000003308	ENG	
984657	2/28/22	2/15/22	BROWN, JOEL	1.00	2.34	ASSIGNED	PC/Computer	100000003308	ENG	
984657	2/28/22	2/15/22	BROWN, JOEL	1.00	0.25	ASSIGNED	Tablet/iPad	100000003308	ENG	
984657	2/28/22	2/15/22	BROWN, JOEL	1.00	0.40	ASSIGNED	Cell Phone	100000003308	ENG	
984657	2/28/22	2/16/22	BROWN, JOEL	2.00	0.80	ASSIGNED	Cell Phone	100000003308	ENG	
984657	2/28/22	2/16/22	BROWN, JOEL	2.00	4.68	ASSIGNED	PC/Computer	100000003308	ENG	
984657	2/28/22	2/16/22	BROWN, JOEL	2.00	0.50	ASSIGNED	Tablet/iPad	100000003308	ENG	
984657	2/28/22	2/18/22	BROWN, JOEL	0.50	0.13	ASSIGNED	Tablet/iPad	100000003308	ENG	
984657	2/28/22	2/18/22	BROWN, JOEL	0.50	1.17	ASSIGNED	PC/Computer	100000003308	ENG	
984657	2/28/22	2/18/22	BROWN, JOEL	0.50	0.20	ASSIGNED	Cell Phone	100000003308	ENG	
984657	2/28/22	2/24/22	BROWN, JOEL	2.00	0.80	ASSIGNED	Cell Phone	100000003308	ENG	
984657	2/28/22	2/24/22	BROWN, JOEL	2.00	4.68	ASSIGNED	PC/Computer	100000003308	ENG	
984657	2/28/22	2/24/22	BROWN, JOEL	2.00	0.50	ASSIGNED	Tablet/iPad	100000003308	ENG	
			<b>BROWN, JOEL Total</b>		<b>20.94</b>					
984657	3/10/22	2/14/22	LOCKHART, SIDNEY	1.00	0.40	ASSIGNED	Cell Phone	100000003308	ENG	
984657	3/10/22	2/14/22	LOCKHART, SIDNEY	1.00	0.25	ASSIGNED	Tablet/iPad	100000003308	ENG	
984657	3/10/22	2/14/22	LOCKHART, SIDNEY	1.00	5.69	ASSIGNED	Blazer/Suburbans	100000003308	ENG	
984657	3/10/22	2/14/22	LOCKHART, SIDNEY	1.00	2.34	ASSIGNED	PC/Computer	100000003308	ENG	
984657	3/10/22	2/15/22	LOCKHART, SIDNEY	1.00	5.69	ASSIGNED	Blazer/Suburbans	100000003308	ENG	
984657	3/10/22	2/15/22	LOCKHART, SIDNEY	1.00	0.25	ASSIGNED	Tablet/iPad	100000003308	ENG	
984657	3/10/22	2/15/22	LOCKHART, SIDNEY	1.00	0.40	ASSIGNED	Cell Phone	100000003308	ENG	
984657	3/10/22	2/15/22	LOCKHART, SIDNEY	1.00	2.34	ASSIGNED	PC/Computer	100000003308	ENG	
984657	3/10/22	2/16/22	LOCKHART, SIDNEY	2.00	0.80	ASSIGNED	Cell Phone	100000003308	ENG	
984657	3/10/22	2/16/22	LOCKHART, SIDNEY	2.00	4.68	ASSIGNED	PC/Computer	100000003308	ENG	
984657	3/10/22	2/16/22	LOCKHART, SIDNEY	2.00	11.38	ASSIGNED	Blazer/Suburbans	100000003308	ENG	
984657	3/10/22	2/16/22	LOCKHART, SIDNEY	2.00	0.50	ASSIGNED	Tablet/iPad	100000003308	ENG	
984657	3/10/22	2/17/22	LOCKHART, SIDNEY	3.00	17.07	ASSIGNED	Blazer/Suburbans	100000003308	ENG	
984657	3/10/22	2/17/22	LOCKHART, SIDNEY	3.00	0.75	ASSIGNED	Tablet/iPad	100000003308	ENG	
984657	3/10/22	2/17/22	LOCKHART, SIDNEY	3.00	1.20	ASSIGNED	Cell Phone	100000003308	ENG	
984657	3/10/22	2/17/22	LOCKHART, SIDNEY	3.00	7.02	ASSIGNED	PC/Computer	100000003308	ENG	
984657	3/10/22	2/25/22	LOCKHART, SIDNEY	2.00	11.38	ASSIGNED	Blazer/Suburbans	100000003308	ENG	
984657	3/10/22	2/25/22	LOCKHART, SIDNEY	2.00	0.50	ASSIGNED	Tablet/iPad	100000003308	ENG	
984657	3/10/22	2/25/22	LOCKHART, SIDNEY	2.00	0.80	ASSIGNED	Cell Phone	100000003308	ENG	
984657	3/10/22	2/25/22	LOCKHART, SIDNEY	2.00	4.68	ASSIGNED	PC/Computer	100000003308	ENG	
984657	3/11/22	3/9/22	LOCKHART, SIDNEY	2.00	4.68	ASSIGNED	PC/Computer	100000003308	ENG	
984657	3/11/22	3/9/22	LOCKHART, SIDNEY	2.00	0.80	ASSIGNED	Cell Phone	100000003308	ENG	
984657	3/11/22	3/9/22	LOCKHART, SIDNEY	2.00	0.50	ASSIGNED	Tablet/iPad	100000003308	ENG	
984657	3/11/22	3/9/22	LOCKHART, SIDNEY	2.00	11.38	ASSIGNED	Blazer/Suburbans	100000003308	ENG	
984657	3/11/22	3/10/22	LOCKHART, SIDNEY	1.00	0.40	ASSIGNED	Cell Phone	100000003308	ENG	
984657	3/11/22	3/10/22	LOCKHART, SIDNEY	1.00	2.34	ASSIGNED	PC/Computer	100000003308	ENG	
984657	3/11/22	3/10/22	LOCKHART, SIDNEY	1.00	5.69	ASSIGNED	Blazer/Suburbans	100000003308	ENG	
984657	3/11/22	3/10/22	LOCKHART, SIDNEY	1.00	0.25	ASSIGNED	Tablet/iPad	100000003308	ENG	
984657	3/11/22	3/11/22	LOCKHART, SIDNEY	2.00	0.80	ASSIGNED	Cell Phone	100000003308	ENG	
984657	3/11/22	3/11/22	LOCKHART, SIDNEY	2.00	4.68	ASSIGNED	PC/Computer	100000003308	ENG	
984657	3/11/22	3/11/22	LOCKHART, SIDNEY	2.00	11.38	ASSIGNED	Blazer/Suburbans	100000003308	ENG	
984657	3/11/22	3/11/22	LOCKHART, SIDNEY	2.00	0.50	ASSIGNED	Tablet/iPad	100000003308	ENG	
			<b>LOCKHART, SIDNEY Total</b>		<b>121.52</b>					
984657	3/11/22	9/14/21	MAES, LESLI	(2.50)	(1.00)	ASSIGNED-D	Cell Phone	100000003308	ENG	
984657	3/11/22	9/14/21	MAES, LESLI	(2.50)	(5.85)	ASSIGNED-D	PC/Computer	100000003308	ENG	
			<b>MAES, LESLI Total</b>		<b>(6.85)</b>					
984662	3/15/22	2/28/22	PARROTT, JEFFREY	1.00	0.25	ASSIGNED	Tablet/iPad	100000003308	ROW	
984662	3/15/22	2/28/22	PARROTT, JEFFREY	1.00	0.40	ASSIGNED	Cell Phone	100000003308	ROW	
984662	3/15/22	2/28/22	PARROTT, JEFFREY	1.00	2.34	ASSIGNED	PC/Computer	100000003308	ROW	
984662	3/15/22	3/8/22	PARROTT, JEFFREY	1.00	2.34	ASSIGNED	PC/Computer	100000003308	ROW	
984662	3/15/22	3/8/22	PARROTT, JEFFREY	1.00	0.40	ASSIGNED	Cell Phone	100000003308	ROW	
984662	3/15/22	3/8/22	PARROTT, JEFFREY	1.00	0.25	ASSIGNED	Tablet/iPad	100000003308	ROW	
984662	3/15/22	2/28/22	PARROTT, JEFFREY	1.00	2.34	ASSIGNED	PC/Computer	100000003308	ROW	
984662	3/15/22	2/28/22	PARROTT, JEFFREY	1.00	0.40	ASSIGNED	Cell Phone	100000003308	ROW	
984662	3/15/22	2/28/22	PARROTT, JEFFREY	1.00	0.25	ASSIGNED	Tablet/iPad	100000003308	ROW	
			<b>PARROTT, JEFFREY Total</b>		<b>8.97</b>					
			<b>Grand Total</b>		<b>144.58</b>					



# Applied Science, Inc.

300 River Place Suite 5400 Detroit, MI 48207  
Phone: (313) 567-3990 Fax: (313) 567-3750  
www.asi-detroit.com

April 6, 2022

Project Invoice #38 (ASI Inv. #8088)

Joel Brown, P.E.  
Civil Engineer III  
Oakland County Water Resources Commissioner's Office  
One Public Works Drive, Building 95 West  
Waterford, MI 48328

Re: Northeast Sanitary Pump Station  
Contract #5470  
(ASI Job No. 1815)

**li # 41133 v#352**

Invoice Period: 2/27/22-3/26/22

Task No.	Task Description	Total This Invoice
1	<b>Transition &amp; Basis of Design</b>	
	<b>Total:</b>	<b>\$ -</b>

Task No.	Task Description	Total This Invoice
2	<b>Design Services for Pump &amp; Electrical Upgrades</b>	
	<b>Total:</b>	<b>\$ -</b>
	Subconsultants:	
	<b>FK Engineering:</b>	\$ -
	<b>NTH Consultants</b>	\$ -
	ASI Markup 5%:	\$ -
	<b>Total Due This Invoice:</b>	<b>\$ -</b>

Task No.	Task Description	Total This Invoice
3	<b>Additional Special Services</b>	
	<b>Total:</b>	<b>\$ -</b>
	Subconsultants:	
	<b>FK Engineering:</b>	\$ -
	ASI Markup 5%:	\$ -
	<b>Total Due This Invoice:</b>	<b>\$ -</b>

Task No.	Task Description	Total This Invoice
5	<b>Construction Services</b>	
	<b>Total:</b>	<b>\$ 14,757.50</b>
	Subconsultants:	
	<b>NTH Consultants</b>	\$ 37,870.02
	<b>Metco Services</b>	\$ 23,580.00
	<b>FK Engineering:</b>	\$ 2,681.76
	ASI Markup 5%:	\$ 3,206.59
	<b>Total Due This Invoice:</b>	<b>\$ 82,095.87</b>

<b>Total Due This Invoice:</b>	<b>\$ 82,095.87</b>
Previous Amount Invoiced:	\$ 2,900,422.36
Total Invoiced To-Date	\$ 2,982,518.23
Contract Task Total:	\$ 4,198,380.00
Amount Remaining:	\$ 1,215,861.77

**84917-149015-730639-1-3309 engcon**

**JTB 4/13/2022**



LG Design is a Subsidiary of CH2M Hill Engineers

Oakland-Macomb Interceptor Drain Drainage District  
Oakland County Water Resources Commissioner  
One Public Works Drive  
Waterford, MI 48328  
248-858-0958

Invoice Contact:  
Sandy.Pepper@Jacobs.com

Remit to:

LG Design, Inc.  
Attn: Judy Rives  
1041 East Butler Road  
Greenville, SC. 29607  
Tax ID : 20-0936384

**82912 - 6010101 - 149090 - 730639 - 5456 - Ch  
21 - v#22147- exp. 6/26/23 - li#41407**

4/13/2022

Invoice Date: 4/5/2022  
CH2M HILL Project No. 705773CH  
CH2M HILL Invoice No. 705773CH037  
Sequential Invoice Number: 38

**PROFESSIONAL SERVICES RENDERED FOR THE OAKLAND-MACOMB INTERCEPTOR DRAIN DRAINAGE DISTRICT (OMIDD)  
BIOTRICKLING FILTER DESIGN AND CONSTRUCTION OVERSIGHT**  
This invoice includes labor and expenses for the period:  
From January 29, 2022 through April 1, 2022

**Authorized Amount: \$ 1,272,470.46**  
Current Invoice: \$ 3,842.51  
Total Invoiced: \$ 1,258,449.32  
Percent Complete: 98.90%  
Remaining Budget: \$ 14,021.14

**Total Amount Due: \$ 3,842.51**

Project/Task Number	Description	Total Budget	Previously Invoiced	Current Invoice	Total Invoiced	Percent Spent	Remaining Budget
1	PROJECT MANAGEMENT	\$ 33,527.00	\$ 33,504.07	\$ -	\$ 33,504.07	99.93%	\$ 22.93
2	PRELIMINARY DESIGN	\$ 73,599.00	\$ 73,519.37	\$ -	\$ 73,519.37	99.89%	\$ 79.63
3	FINAL DESIGN	\$ 195,027.00	\$ 195,009.84	\$ -	\$ 195,009.84	99.99%	\$ 17.16
4	BIDDING	\$ 31,841.46	\$ 31,840.94	\$ -	\$ 31,840.94	100.00%	\$ 0.52
5	CONSTRUCTION OBSERVATION	\$ 325,731.16	\$ 325,711.92	\$ -	\$ 325,711.92	99.99%	\$ 19.24
6	REVIEW SUBMITTALS	\$ 85,648.00	\$ 85,581.87	\$ -	\$ 85,581.87	99.92%	\$ 66.13
7	CHANGES & CLAIMS	\$ 17,361.00	\$ 17,274.11	\$ -	\$ 17,274.11	99.50%	\$ 86.89
8	SITE INSPECTION	\$ 31,998.07	\$ 31,975.53	\$ -	\$ 31,975.53	99.93%	\$ 22.54
9	PREPARE O&M MANUAL	\$ 21,715.50	\$ 21,695.78	\$ -	\$ 21,695.78	99.91%	\$ 19.72
10	PROVIDE OPERATING TRAINING	\$ 9,082.00	\$ 9,062.30	\$ -	\$ 9,062.30	99.78%	\$ 19.70
11	ASSIST WITH FACILITY START-UP	\$ 17,129.00	\$ 17,081.46	\$ -	\$ 17,081.46	99.72%	\$ 47.54
12	PREPARE RECORD DRAWINGS	\$ 9,803.00	\$ 9,715.13	\$ -	\$ 9,715.13	99.10%	\$ 87.87
13	WARRANTY & PERFORMANCE REVIEWS	\$ 15,370.00	\$ 15,352.92	\$ -	\$ 15,352.92	99.89%	\$ 17.08
14	PROJECT PLANNING	\$ 25,000.00	\$ 24,997.75	\$ -	\$ 24,997.75	99.99%	\$ 2.25
EX	EXPENSES	\$ 17,175.62	\$ 17,175.62	\$ -	\$ 17,175.62	100.00%	\$ -
SUB.METCO	ELECTRICAL ENGINEERING	\$ 74,194.50	\$ 74,194.50	\$ -	\$ 74,194.50	100.00%	\$ -
SUB.NTH	GEOTECH INVESTIGATION	\$ 262,327.15	\$ 262,327.15	\$ -	\$ 262,327.15	100.00%	\$ -
SUB.SDA	SITE SURVEY	\$ 5,250.00	\$ 5,250.00	\$ -	\$ 5,250.00	100.00%	\$ -
<b>Subtotal:</b>		\$ 1,251,779.46	\$ 1,251,270.26	\$ -	\$ 1,251,270.26	99.96%	\$ 509.20
<b>Allowance</b>		\$ 20,691.00	\$ 3,336.55	\$ 3,842.51	\$ 7,179.06	34.70%	\$ 13,511.94
<b>Total:</b>		\$ 1,272,470.46	\$ 1,254,606.82	\$ 3,842.51	\$ 1,258,449.32	134.66%	\$ 14,021.14

**OUTSTANDING INVOICES:**

INVOICE DATE	INVOICE #	AMOUNT
1/28/2022	705773CH036	\$ 4,409.10
<b>Total:</b>		\$ 4,409.10
Current invoice		\$ 3,842.51
<b>TOTAL DUE:</b>		\$ 8,251.61

**Payment term: 30 calendar days (NET)**

FINANCE CHARGES WILL BE ASSESSED AT 1½ PERCENT PER MONTH (OR MAXIMUM PERMISSIBLE UNDER STATE LAW) ON ALL ACCOUNTS OVERDUE UNLESS STATED OTHERWISE IN OUR CONTRACT. CH2M HILL IS INCORPORATED.

**Electronic payment details:**

Beneficiary Bank: **Bank of America**  
Account Name: **CH2M HILL Engineers, Inc.**  
Transit for ACH: **111000012**  
Transit for Wires: **026009593**  
Account No (USD): **4451457732**  
SWIFT: **BOFAUS3N**

# CLARK HILL

P.L.C.

ATTORNEYS AT LAW

212 East Grand River Avenue  
Lansing, Michigan 48906-4328  
Telephone (517) 318-3100  
Fed.ID # 38-0425840

## INVOICE

Invoice # 1070310

Oakland-Macomb Interceptor Drain Drainage District March 4, 2021  
Attn: Megan Koss, Esq. Client: 58434  
1 Public Works Drive Matter: 404547  
Waterford, MI 48328  
kossm@oakgov.com; korths@oakgov.com  
cookek@oakgov.com

=====

RE: Northeast Interceptor East Arm Improvements

FOR SERVICES RENDERED through February 28, 2021

Total Services: \$1,944.00

STATEMENT TOTAL \$1,944.00

**84917 - 149015 - 731073 - 1-3308 - LEGAL - 5113 - v#2788 - li#39308 - exp.  
5/15/22**



4/5/2022

PAYABLE UPON RECEIPT IN U.S. DOLLARS

# CLARK HILL

P.L.C.

ATTORNEYS AT LAW

212 East Grand River Avenue  
Lansing, Michigan 48906-4328  
Telephone (517) 318-3100  
Fed.ID # 38-0425840

## INVOICE

Invoice # 1091359

Oakland-Macomb Interceptor Drain Drainage District May 13, 2021  
Attn: Megan Koss, Esq. Client: 58434  
1 Public Works Drive Matter: 404547  
Waterford, MI 48328  
kossm@oakgov.com; korths@oakgov.com  
cookek@oakgov.com

=====

RE: Northeast Interceptor East Arm Improvements

FOR SERVICES RENDERED through April 30, 2021

Total Services: \$2,079.00

STATEMENT TOTAL \$2,079.00

84917 - 149015 - 731073 - 1-3308 - LEGAL - 5113 - v#2788 - li#39308 - exp.  
5/15/22



4/5/2022

PAYABLE UPON RECEIPT IN U.S. DOLLARS

# CLARK HILL

P.L.C.

ATTORNEYS AT LAW

212 East Grand River Avenue  
Lansing, Michigan 48906-4328  
Telephone (517) 318-3100  
Fed.ID # 38-0425840

## INVOICE

Invoice # 1119387

Oakland-Macomb Interceptor Drain Drainage District August 12, 2021  
Attn: Megan Koss, Esq. Client: 58434  
1 Public Works Drive Matter: 404547  
Waterford, MI 48328  
kossm@oakgov.com; korths@oakgov.com  
cookek@oakgov.com

=====

RE: Northeast Interceptor East Arm Improvements

FOR SERVICES RENDERED through July 31, 2021

Total Services: \$2,484.00

STATEMENT TOTAL \$2,484.00

84917 - 149015 - 731073 - 1-3308 - ROW - 5113 - v#2788 - li#39308 - exp.  
5/15/22



4/5/2022

PAYABLE UPON RECEIPT IN U.S. DOLLARS





Contract No. 5087  
Speedtype: 61M8291248  
Fund: 82912  
Program: 149139  
Account: 731038

March 22, 2022

4/13/2022

Oakland County Water Resources Commissioner, MI  
Attn: Megan Koss, Esq.  
One Public Works Drive  
Waterford, MI 48328-1907  
WRCLegalInvoices@oakgov.com

Invoice: 1185359  
Date: 03/16/2022  
Client: 30164  
Matter: 438991

Matter Name: Bypass Pumping Easement

---

**LEGAL SERVICES RENDERED AND COSTS ADVANCED THROUGH FEBRUARY 28, 2022**

Total Fees:	\$	994.50
<b>Total Due This Invoice:</b>	<b>\$</b>	<b>994.50</b>



4/4/2022

84917 - 149015 - 731073 - 1-3308 - LEGAL - 5113 -  
v#2788 - li#39308 - exp. 5/15/22

Oakland-Macomb Interceptor Drain Drainage District  
Attn: Megan Koss, Esq.  
1 Public Works Drive  
Waterford, MI 48328  
WRClegalinvoices@oakgov.com

Invoice: 1185477  
Date: 03/17/2022  
Client: 58434  
Matter: 404547

Matter Name: Northeast Interceptor East Arm Improvements

---

**LEGAL SERVICES RENDERED AND COSTS ADVANCED THROUGH FEBRUARY 28, 2022**

Total Fees:	\$	2,430.00
<b>Total Due This Invoice:</b>	<b>\$</b>	<b>2,430.00</b>



82912 - 6010101 - 149030 - 731073 -5113 - v#2788 -  
exp. 5/15/22

A handwritten signature in black ink, appearing to read 'J. B.'.

4/4/2022

Oakland-Macomb Interceptor Drain Drainage District  
Attn: Megan Koss, Esq.  
1 Public Works Drive  
Waterford, MI 48328  
WRClegalinvoices@oakgov.com

Invoice: 1185478  
Date: 03/17/2022  
Client: 58434  
Matter: 424741

Matter Name: GLWA Model Wastewater Contract

---

**LEGAL SERVICES RENDERED AND COSTS ADVANCED THROUGH FEBRUARY 28, 2022**

Total Fees:	\$	270.00
<b>Total Due This Invoice:</b>	<b>\$</b>	<b>270.00</b>



82912 - 149090 - 730660 - 6007 - Ch. 21  
 v#763  
 exp. 3/1/23

**Invoice # 8123-OMID**

3/26/22

PO Box 531330  
 Livonia, MI 48153

*Joel Brown*

4/1/2022

**WRC OMID**

TO: Oakland County WRC

11010 E State Fair St. Pump Station

ATTN: Joel Brown

DESCRIPTION OF WORK COMPLETED	Qty.	Unit	Hrs.	Rate	Total Per Line
<b>Mobilize, Excavate Existing Hydrant, Remove &amp; Replace. Adjusted Fittings and Thrust Block</b>					
Mobilize & Demobilize Excavator	2	EA	-	\$ 425.00	\$ 850.00
Service Trucks	1	HR	10	\$ 35.00	\$ 350.00
Excavator & Operator	2	HR	10	\$ 155.00	\$ 3,100.00
Skid Steer & Operator Regular Time	1	HR	8	\$ 80.00	\$ 640.00
Skid Steer & Operator Over Time	1	HR	2	\$ 88.00	\$ 176.00
(6)Labor, Regular Time	6	HR	8	\$ 48.00	\$ 2,304.00
(6)Labor, Over Time	6	HR	2	\$ 58.00	\$ 696.00
(2)Labor/Truck Driver, Regular Time	2	HR	8	\$ 48.00	\$ 768.00
(2)Labor/Truck Driver, Over Time	2	HR	2	\$ 58.00	\$ 232.00
Tri Axle Dump Truck	2	HR	10	\$ 80.00	\$ 1,600.00
Power Saw	1	EA	-	\$ 100.00	\$ 100.00
Plates, Sheeting	1	Day	1	\$ 500.00	\$ 500.00
Trench Box	1	Day	1	\$ 500.00	\$ 500.00
Generator	1	Day	1	\$ 100.00	\$ 100.00
Pump	2	Day	1	\$ 60.00	\$ 120.00
Compaction	1	HR	2	\$ 84.00	\$ 168.00
					\$ 12,204.00
<b>Materials</b>					
21AA Limestone	12	Ton	-	\$ 14.45	\$ 173.40
6A Stone	8	Ton	-	\$ 14.45	\$ 115.60
Class II Sand	20	Ton	-	\$ 13.50	\$ 270.00
Haul out	32	Yard	-	\$ 11.00	\$ 352.00
					\$ 911.00
<b>TOTAL</b>					<b>\$ 13,115.00</b>

Vince D'Angelo (248) 515-1942



INVOICE DATE: MARCH 9, 2022  
 INVOICE NO.: 1671430

OAKLAND COUNTY WATER RESOURCES COMMISSIONER  
 ATTORNEY & INSURANCE ADMINISTRATOR  
 ONE PUBLIC WORKS DRIVE, #95  
 WATERFORD, MI 48328

ATTN: STEVE KORTH

**82912 - 6010101 - 149030 - 731073 - 5089 - Ch. 21 - v# 4978**  
**- li# 39111 - exp. 4/30/22**

CLIENT/MATTER NO.: 012840-00436

4/1/2022

RE: PREPARE BOARD MEMORANDUM RE LOCKOUT-TAGOUT (LOTO) ISSUE

*PRIVILEGED AND CONFIDENTIAL*

FOR PROFESSIONAL SERVICES THROUGH FEBRUARY 28, 2022

USD

TOTAL FEES CURRENT INVOICE .....	\$	<u>118.50</u>
<b>TOTAL CURRENT INVOICE .....</b>	<b>\$</b>	<b><u>118.50</u></b>

*KC* 03/18/2022

Remittance Instructions		
***Terms: Due and Payable Upon Receipt***		
Mail To:	ACH Instructions:	Wire Instructions:
Dickinson Wright PLLC 2600 W. Big Beaver Suite 300 Troy, MI 48084	JP Morgan Chase Bank N.A. 28660 Northwestern Highway Southfield, MI 48034 ABA Number: 072 000 326 Account# 38852  <i>(Please Reference Invoice Numbers)</i>	JP Morgan Chase Bank N.A. 28660 Northwestern Highway Southfield, MI 48034 ABA Number: 021 000 021 Swift Code: CHASUS33 (International) Account# 38852  <i>(Please Reference Invoice Numbers)</i>



Knowledgeable • Professional • Attentive • Likeable

29770 Hudson Drive Novi, MI 48377  
Phone: (586) 978-7200  
hesco-mi.com

Invoice No. 2213496

Date: 03/07/2022

82912 - 149130 - 730660 - 5819 - Ch. 21 -  
v#3091 - exp. 6/30/22 - li#42703

Billed To: OMID Drainage District  
1 Public Works Drive  
Waterford MI 48328

4/1/2022

Project: 2019807S OMID Flow Control Structures

Contact: Terry Moore P.O.# Sewer Fund #149130 Salesperson: David Burkel Due Date: 04/06/2022

Description	Unit	Qty	Rate	Amount
<b>2/26/2022 - Preventative Maineneance and Inspection</b>				
WO 00510 – CS-8				
Senior Tech	Hours	6.00	185.00	1,110.00
Tech 1	Hours	6.00	120.00	720.00
Tech 1	Hours	5.00	120.00	600.00
Tech 1	Hours	5.00	120.00	600.00
<b>Parts</b>				
Return Filter	Each	1.00	17.25	17.25
Pressure Filter	Each	1.00	60.00	60.00
Hydraulic Oil, 25 Gallons	Each	1.00	480.00	480.00
Hydraulic Oil, Credit per D.BURKEL	Each	-1.00	865.00	-865.00
Gate Hardware	Total	1.00	20.00	20.00

Notes:

WO 00510 – CS-8 Preventative Maintenance and Inspection.

*TM - 3-21-22*

Non-Taxable Amount:	2,742.25
Taxable Amount:	0.00
Sales Tax:	0.00
Total Invoice	2,742.25
Payments/Credits:	0.00
<b>Amount Due</b>	<b>2,742.25</b>



Knowledgeable • Professional • Attentive • Likeable

29770 Hudson Drive Novi, MI 48377  
Phone: (586) 978-7200  
hesco-mi.com

Invoice No. 2213521

Date: 03/21/2022

82912 - 149130 - 730660 - 5819 - Ch. 21 - v#3091 - exp.  
6/30/22 - li#42703

Billed To: OMID Drainage District  
1 Public Works Drive  
Waterford MI 48328

4/1/2022

Project: 2019807S OMID Flow Control Structures

Contact: Terry Moore      P.O.# Sewer Fund #149130      Salesperson: David Burkel      Due Date: 04/20/2022

Description	Unit	Qty	Rate	Amount
3/7/2022 - Filter Change WO 00558 – CS-5 Senior Tech	Hours	2.00	185.00	370.00
Parts				
Pressure Filter	Each	1.00	60.00	60.00

Notes:  
WO 00558 – CS-5 Filter change

*TM-3-22-22*

Non-Taxable Amount:	430.00
Taxable Amount:	0.00
Sales Tax:	0.00
Total Invoice	430.00
Payments/Credits:	0.00
<b>Amount Due</b>	<b>430.00</b>



16142 Collection Center Drive  
 Chicago, IL 60693-0002  
 (877) 759-4365

Invoice # <b>84958</b>	Page 1 of 1
Account Number	Date
OAKLINT-01	3/28/2022
BALANCE DUE ON	
4/22/2022	
AMOUNT PAID	Amount Due
	\$47,950.43

Oakland-Macomb Interceptor Drain **Drainage District (OMIDD)**  
**Attn: Joel Brown**  
 Building 95 West, One Public Works Dr  
 Waterford, MI 48328

**Project: Northeast Sewage Pump Station**

Payment Methods:

ACH/Wire Information

Bank of America  
 Acct Name: Meadowbrook Inc.  
 Acct Number: 5401978514  
 ACH: Acct ABA #: 071000039  
 Wire: Acct ABA #: 026009593

Make checks payable to:

Meadowbrook Insurance Agency

**NESPS Safety Consultant & Administration** Policy Number **OCIPNESPSAD MIN21** Effective: 9/20/21 to 9/20/22

Item #	Trans Eff Date	Due Date	Trans	Description	Amount
256106	9/20/2021	4/22/2022	RENB	3 of 4 Quarterly Installments	\$44,200.00
268496	9/20/2021	4/22/2022	RENB	OMIDD CSC - Overtime from October 3, 2021 to January 1, 2022 (32 Hrs @ Standard Rate \$85.00/Hr)	\$2,720.00
298146	9/20/2021	4/22/2022	RENB	OMIDD CSC Project Related Expense Reimbursement (See attached summary of expenses)	\$1,030.43

Payment due upon receipt.

Total Invoice Balance: **\$47,950.43**

**84917 - 6010101 - 149015 - 730940 - 4724 - 1-3309 - Ch. 21**

LI # 37406 Exp 6/1/26

4/1/2022





INVOICE NO. 1811-39

DATE: April 4, 2022

METCO PROJECT NO. 1811

INVOICE PERIOD: 2/28 thru 4/3/2022

Contract ID 00000000000000000000517

Vendor ID 000020486

TO: OMIDD

Water Resources Commissioner  
One Public Works Drive  
Waterford, MI 48328

Attn: Mr. Sid Lockhart, PE  
Deputy Chief Engineer/Special Projects Manager

TITLE: OMID & NESPS Operation and Maintenance

**Operational Plan**

**OMID Operations - Fund 82912, Program 149130, Account 730373 (3.1-3.4A & 3.4B)**

Name	Title	Hrs.	Rate/Hr.	Amount
Raj Vijayendran, PE	Principal Engineer	0.0	\$ 215.00	\$ -
Terry Moore	Operations Manager	44.0	\$ 145.00	\$ 6,380.00
Terry Moore	Operations Manager (Overtim	2.0	\$ 195.00	\$ 390.00
Darrin Green	Staff Engineer	46.0	\$ 90.00	\$ 4,140.00
Darrin Green	Staff Engineer-(Overtime)	1.0	\$ 135.00	\$ 135.00
Anthony Vozza	Staff Engineer	33.0	\$ 90.00	\$ 2,970.00
Anthony Vozza	Staff Engineer-(Overtime)	0.0	\$ 135.00	\$ -
Rosana Santos	Administrative Assoc.	0.0	\$ 73.79	\$ -
<b>Subtotal OMID Operatons:</b>				<b>\$ 14,015.00</b>

**NEPS Operations - Fund 82912, Program 149090, Account 730373 (3.1-3.4A & 3.4B)**

Name	Title	Hrs.	Rate/Hr.	Amount
Raj Vijayendran, PE	Principal Engineer	8.0	\$ 215.00	\$ 1,720.00
Terry Moore	Operations Manager	50.0	\$ 145.00	\$ 7,250.00
Terry Moore	Operations Manager (Overtim	12.0	\$ 195.00	\$ 2,340.00
Darrin Green	Staff Engineer	52.0	\$ 90.00	\$ 4,680.00
Darrin Green	Staff Engineer-(Overtime)	0.0	\$ 135.00	\$ -
Anthony Vozza	Staff Engineer	29.0	\$ 90.00	\$ 2,610.00
Anthony Vozza	Staff Engineer-(Overtime)	2.0	\$ 135.00	\$ 270.00
Rosana Santos	Administrative Assoc.	4.0	\$ 73.79	\$ 295.16
<b>Subtotal NEPS Operations</b>				<b>\$ 19,165.16</b>
<b>Subtotal Operations</b>				<b>\$ 33,180.16</b>

**Maintenance & Asset Management**

**OMID Maintenance – Fund 82912, Program 149130, Account 730646 (3.2-3.3-3.4C & ALLOWANCE)**

Name	Title	Hrs.	Rate/Hr.	Amount
Terry Moore	Operations Manager	44.0	\$ 145.00	\$ 6,380.00
Terry Moore	Operations Manager (Overtim	0.0	\$ 195.00	\$ -
Anthony Vozza	Staff Engineer	15.0	\$ 90.00	\$ 1,350.00
Darrin Green	Staff Engineer	12.0	\$ 90.00	\$ 1,080.00
<b>Subtotal OMID Maintenance:</b>				<b>\$ 8,810.00</b>

**NEPS Maintenance – Fund 82912, Program 149090, Account 730646 (3.2-3.3-3.4C & ALLOWANCE)**

Name	Title	Hrs.	Rate/Hr.	Amount
Raj Vijayendran, PE	Principal Engineer	8.0	\$ 215.00	\$ 1,720.00
Terry Moore	Operations Manager	50.0	\$ 145.00	\$ 7,250.00
Terry Moore	Operations Manager (Overtim	0.0	\$ 195.00	\$ -
Daniel Martel	Sr. Project Coordinator	0.0	\$ 145.00	\$ -
Sean Grant	Sr. Project Engineer	0.0	\$ 145.00	\$ -

Travis Ford	Sr. Project Engineer	4.0	\$	145.00	\$	580.00
Shailesh Patel	Sr. Project Engineer	0.0	\$	145.00	\$	-
Darrin Green	Staff Engineer	50.0	\$	90.00	\$	4,500.00
Darrin Green	Staff Engineer-(Overtime)	0.0	\$	135.00	\$	-
Anthony Vozza	Staff Engineer	77.0	\$	90.00	\$	6,930.00
Anthony Vozza	Staff Engineer-(Overtime)	0.0	\$	135.00	\$	-
Brandon Brochue	Designer/Drafter	0.0	\$	85.00	\$	-
	<b>Subtotal:</b>		\$		\$	<b>20,980.00</b>
	<b>Maintenance Services (see attached invoices):</b>		\$		\$	<b>5,674.82</b>
	<b>Subtotal NEPS Maintenance:</b>		\$		\$	<b>26,654.82</b>
	<b>Subtotal Maintenance:</b>		\$		\$	<b>35,464.82</b>

**Task 6.0 NEXGEN Asset Management Implementation Services – #1-2842 Fund 82912, Program 149662, Account 731444 ENGCON**

<u>Name</u>	<u>Title</u>	<u>Hrs.</u>		<u>Rate/Hr.</u>		<u>Amount</u>
Raj Vijayendran, PE	Principal Engineer	0.0	\$	215.00	\$	-
Terry Moore	Operations Manager	0.0	\$	145.00	\$	-
Terry Moore	Operations Manager (Overtim	0.0	\$	195.00	\$	-
Sean Grant	Sr. Project Engineer	15.0	\$	145.00	\$	2,175.00
Darrin Green	Staff Engineer	0.0	\$	90.00	\$	-
Darrin Green	Staff Engineer-(Overtime)	0.0	\$	135.00	\$	-
Anthony Vozza	Staff Engineer	0.0	\$	90.00	\$	-
Abhishek Shah	Staff Engineer	90.0	\$	90.00	\$	8,100.00
Brandon Brochue	Designer/Drafter	0.0	\$	85.00	\$	-
	<b>Subtotal 6.0:</b>		\$		\$	<b>10,275.00</b>

**Task 12.0 - As-Needed Services**

<b>Additional General/Excess Liability Insurance Fee:</b>	\$	-
<b>Subtotal 12.0:</b>	\$	-

**TOTAL AMOUNT DUE THIS INVOICE: \$ 78,919.98**



**MOTOR CITY ELECTRIC TECHNOLOGIES**

9440 GRINNELL  
DETROIT, MI 48213-1151  
PHONE (313) 921-5300 FAX (313) 921-5310

# INVOICE

15020 OAKLAND COUNTY  
  
WATER RESOURCES  
ONE PUBLIC WORKS DRIVE  
  
WATERFORD MI 48328-1907

Customer  
PO Number

Job Number	Sub Job	Contract Number	Date		Application	
			Performed	Date	Date	Number
921567		2	00/00/0000	11/30/2021		36819

OMID SANITARY PUMP  
STATION SCADA

Item No	Description of Work	Contract Amount	Previous Billings	Current Amount	To Date Completed & Stored	Balance to Finish	Current Retainage
001	OAKLAND MACOMB INTERCEPTOR DRAINAGE	10,200.00	.00	10,200.00	10,200.00	.00	.00
	Totals	10,200.00		10,200.00	.00		
	Less Retained			.00			
	Invoice Total			10,200.00			

ATTN: ACCOUNTS PAYABLE DEPT.  
 PROVIDE ELECTRICAL SUPERVISION, LABOR,  
 MATERIAL AND EQUIPMENT AS DIRECTED FOR  
 OAKLAND MACOMB INTERCEPTOR DRAINAGE DISTRICT  
 CONTROL STRUCURE CS-9 SCADA SERVICES.

**84917- 6010101 - 149015- 730660 - 1-3308 - FAC- 5469 - Ch. 21 - v# 7755 - li# 41132 - exp. 12/31/23**

4/12/2022

*TM*

3-28-22

Complete electrical construction

"We hereby certify that the articles and services covered by this invoice were produced and performed in compliance with all applicable requirements of Section 6, 7 and 12 of the Fair Labor Standards Act, as amended, and of regulations and orders of the United States Department of Labor issued under Section 14 thereof."



**MOTOR CITY ELECTRIC TECHNOLOGIES INC.**

AUTOMATION AND CONTROLS SOLUTIONS

9440 GRINNELL

DETROIT, MI 48213-1151

PHONE (313) 921-5300 FAX (313) 921-5310

"AN EQUAL OPPORTUNITY EMPLOYER"

# INVOICE

OMID  
ONE PUBLIC WORKS DRIVE, BUILDING 95  
WATERFORD, MI 48328-

Customer  
PO Number

Job Number	Sub Job	Contract Number	Date Performed	Application	
				Date	Number
921567	0	001	6/1/2021	6/16/2021	93699

SID LOCKHART

Item No	Description of Work	Contract Amount	Previous Billings	Current Amount	To Date Complete & Stored	Balance To Finish	Current Retainage
001	NESP SCADA CUTOVER	\$315.00	-	\$315.00	\$315.00	-	-
<b>Totals:</b>		<b>\$315.00</b>		<b>\$315.00</b>	<b>\$315.00</b>		
Less Retained:				-			
<b>Invoice Total:</b>				<b>\$315.00</b>			

AS NEEDED ELECTRICAL AND ENGINEERING SERVICE

SEE ATTACHED INVOICE SUMMARY AND FIELD REPORT

**82912 - 6010101 - 149130- 730660 - 5469 - Ch. 21 - v# 7755 - li# 41132 - exp. 12/31/23**

9-15-21

4/1/2022

WORK COMPLETED 6/1/2021 -

WORK ORDER #00287

complete electrical construction

"We hereby certify that the articles and services covered by this invoice were produced and performed in compliance with all applicable requirements of Section 6, 7 and 12 of the Fair Labor Standards Act, as amended, and of regulations and orders of the United States Department of Labor issued under Section 14 thereof."



**MOTOR CITY ELECTRIC TECHNOLOGIES INC.**

AUTOMATION AND CONTROLS SOLUTIONS

9440 GRINNELL

DETROIT, MI 48213-1151

PHONE (313) 921-5300 FAX (313) 921-5310

"AN EQUAL OPPORTUNITY EMPLOYER"

# INVOICE

OMID  
ONE PUBLIC WORKS DRIVE, BUILDING 95  
WATERFORD, MI 48328-

Customer  
PO Number

Job Number	Sub Job	Contract Number	Date Performed	Application	
				Date	Number
921567	0	001	5/19/2021	6/29/2021	93730

SID LOCKHART

Item No	Description of Work	Contract Amount	Previous Billings	Current Amount	To Date Complete & Stored	Balance To Finish	Current Retainage
001	NESP SCADA CUTOVER	\$154.00	-	\$154.00	\$154.00	-	-
<b>Totals:</b>		<b>\$154.00</b>		<b>\$154.00</b>	<b>\$154.00</b>		
Less Retained:				-			
<b>Invoice Total:</b>				<b>\$154.00</b>			

AS NEEDED ELECTRICAL AND ENGINEERING SERVICE

SEE ATTACHED INVOICE SUMMARY AND FIELD REPORT

**82912 - 6010101 - 149130- 730660 - 5469 - Ch. 21 - v# 7755 - li# 41132 - exp. 12/31/23**

WORK PERFORMED 5/19/2021

4/1/2022

TW 9-16-21

complete electrical construction

"We hereby certify that the articles and services covered by this invoice were produced and performed in compliance with all applicable requirements of Section 6, 7 and 12 of the Fair Labor Standards Act, as amended, and of regulations and orders of the United States Department of Labor issued under Section 14 thereof."



**MOTOR CITY ELECTRIC TECHNOLOGIES INC.**

AUTOMATION AND CONTROLS SOLUTIONS

9440 GRINNELL

DETROIT, MI 48213-1151

PHONE (313) 921-5300 FAX (313) 921-5310

"AN EQUAL OPPORTUNITY EMPLOYER"

# INVOICE

OMID  
ONE PUBLIC WORKS DRIVE, BUILDING 95  
WATERFORD, MI 48328-

Customer  
PO Number

Job Number	Sub Job	Contract Number	Date Performed	Application	
				Date	Number
921567	0	001	6/5/2021	6/29/2021	93731

SID LOCKHART

Item No	Description of Work	Contract Amount	Previous Billings	Current Amount	To Date Complete & Stored	Balance To Finish	Current Retainage
001	NESP SCADA CUTOVER	\$216.00	-	\$216.00	\$216.00	-	-
<b>Totals:</b>		<b>\$216.00</b>		<b>\$216.00</b>	<b>\$216.00</b>		
Less Retained:				-			
<b>Invoice Total:</b>				<b>\$216.00</b>			

AS NEEDED ELECTRICAL AND ENGINEERING SERVICE

SEE ATTACHED INVOICE SUMMARY AND FIELD REPORT

8-13-21

WORK PERFORMED 6/5/2021

**82912 - 6010101 - 149090- 730660 - 5469 - Ch. 21 - v# 7755 - li# 41132 - exp. 12/31/23**

4/1/2022

complete electrical construction

"We hereby certify that the articles and services covered by this invoice were produced and performed in compliance with all applicable requirements of Section 6, 7 and 12 of the Fair Labor Standards Act, as amended, and of regulations and orders of the United States Department of Labor issued under Section 14 thereof."



**MOTOR CITY ELECTRIC TECHNOLOGIES INC.**

AUTOMATION AND CONTROLS SOLUTIONS

9440 GRINNELL

DETROIT, MI 48213-1151

PHONE (313) 921-5300 FAX (313) 921-5310

"AN EQUAL OPPORTUNITY EMPLOYER"

# INVOICE

OMID  
ONE PUBLIC WORKS DRIVE, BUILDING 95  
WATERFORD, MI 48328-

Customer  
PO Number

Job Number	Sub Job	Contract Number	Date Performed	Application	
				Date	Number
921567	0	001	6/12/2021	6/29/2021	93732

SID LOCKHART

Item No	Description of Work	Contract Amount	Previous Billings	Current Amount	To Date Complete & Stored	Balance To Finish	Current Retainage
001	NESP SCADA CUTOVER	\$3,096.00	-	\$3,096.00	\$3,096.00	-	-
<b>Totals:</b>		<b>\$3,096.00</b>		<b>\$3,096.00</b>	<b>\$3,096.00</b>		
Less Retained:				-			
<b>Invoice Total:</b>				<b>\$3,096.00</b>			

AS NEEDED ELECTRICAL AND ENGINEERING SERVICE

SEE ATTACHED INVOICE SUMMARY AND FIELD REPORT

*TM* 9-15-21

WORKED PERFORMED 6/6-12/2021

**82912 - 6010101 - 149090- 730660 - 5469 - Ch. 21 - v# 7755 - li# 41132 - exp. 12/31/23**

*JL Ben*

4/1/2022

complete electrical construction

"We hereby certify that the articles and services covered by this invoice were produced and performed in compliance with all applicable requirements of Section 6, 7 and 12 of the Fair Labor Standards Act, as amended, and of regulations and orders of the United States Department of Labor issued under Section 14 thereof."



**MOTOR CITY ELECTRIC TECHNOLOGIES INC.**

AUTOMATION AND CONTROLS SOLUTIONS

9440 GRINNELL

DETROIT, MI 48213-1151

PHONE (313) 921-5300 FAX (313) 921-5310

"AN EQUAL OPPORTUNITY EMPLOYER"

# INVOICE

OMID  
ONE PUBLIC WORKS DRIVE, BUILDING 95  
WATERFORD, MI 48328-

Customer  
PO Number

Job Number	Sub Job	Contract Number	Date Performed	Application	
				Date	Number
921567	0	001	6/25/2021	6/29/2021	93733

SID LOCKHART

Item No	Description of Work	Contract Amount	Previous Billings	Current Amount	To Date Complete & Stored	Balance To Finish	Current Retainage
001	NESP SCADA CUTOVER	\$180.00	-	\$180.00	\$180.00	-	-
<b>Totals:</b>		<b>\$180.00</b>		<b>\$180.00</b>	<b>\$180.00</b>		
Less Retained:				-			
<b>Invoice Total:</b>				<b>\$180.00</b>			

AS NEEDED ELECTRICAL AND ENGINEERING SERVICE

SEE ATTACHED INVOICE SUMMARY AND FIELD REPORT

**82912 - 6010101 - 149090- 730660 - 5469 - Ch. 21 - v# 7755 - li# 41132 - exp. 12/31/23**

WORK PERFORMED 6/25/2021

4/1/2022

1-31-22

complete electrical construction

"We hereby certify that the articles and services covered by this invoice were produced and performed in compliance with all applicable requirements of Section 6, 7 and 12 of the Fair Labor Standards Act, as amended, and of regulations and orders of the United States Department of Labor issued under Section 14 thereof."





**MOTOR CITY ELECTRIC TECHNOLOGIES INC.**

AUTOMATION AND CONTROLS SOLUTIONS

9440 GRINNELL

DETROIT, MI 48213-1151

PHONE (313) 921-5300 FAX (313) 921-5310

"AN EQUAL OPPORTUNITY EMPLOYER"

# INVOICE

OMID  
ONE PUBLIC WORKS DRIVE, BUILDING 95  
WATERFORD, MI 48328-

Customer  
PO Number  
Work Order #329

Job Number	Sub Job	Contract Number	Date Performed	Application	
				Date	Number
921567	0	001	7/15/2021	7/28/2021	93767

SID LOCKHART

Item No	Description of Work	Contract Amount	Previous Billings	Current Amount	To Date Complete & Stored	Balance To Finish	Current Retainage
001	NESP SCADA CUTOVER	\$495.00	-	\$495.00	\$495.00	-	-
<b>Totals:</b>		<b>\$495.00</b>		<b>\$495.00</b>	<b>\$495.00</b>		
Less Retained:				-			
<b>Invoice Total:</b>				<b>\$495.00</b>			

AS NEEDED ELECTRICAL AND ENGINEERING SERVICE

SEE ATTACHED FIELD REPORT AND INVOICE SUMMARY

*TM* 9-15-21

WORK ORDER #329 - COMPLETED 7/15/2021

**82912 - 6010101 - 149090- 730660 - 5469 - Ch. 21 - v# 7755 - li# 41132 - exp. 12/31/23**

*Jed Ben* 4/1/2022

complete electrical construction

"We hereby certify that the articles and services covered by this invoice were produced and performed in compliance with all applicable requirements of Section 6, 7 and 12 of the Fair Labor Standards Act, as amended, and of regulations and orders of the United States Department of Labor issued under Section 14 thereof."



**MOTOR CITY ELECTRIC TECHNOLOGIES INC.**

AUTOMATION AND CONTROLS SOLUTIONS

9440 GRINNELL  
 DETROIT, MI 48213-1151  
 PHONE (313) 921-5300 FAX (313) 921-5310  
 "AN EQUAL OPPORTUNITY EMPLOYER"

# INVOICE

OMID  
 ONE PUBLIC WORKS DRIVE, BUILDING 95  
 WATERFORD, MI 48328-

Customer  
 PO Number

Job Number	Sub Job	Contract Number	Date Performed	Application	
				Date	Number
921567	0	001	2/8/2021	7/28/2021	93768

SID LOCKHART

Item No	Description of Work	Contract Amount	Previous Billings	Current Amount	To Date Complete & Stored	Balance To Finish	Current Retainage
001	NESP SCADA CUTOVER	\$4,620.00	-	\$4,620.00	\$4,620.00	-	-
<b>Totals:</b>		<b>\$4,620.00</b>		<b>\$4,620.00</b>	<b>\$4,620.00</b>		
Less Retained:				-			
<b>Invoice Total:</b>				<b>\$4,620.00</b>	<i>T.M.</i>	<b>1-31-22</b>	

AS NEEDED ELECTRICAL AND ENGINEERING SERVICE

SEE ATTACHED INVOICE SUMMARY AND FIELD REPORTS

GENERATOR & PLC PROGRAMMING REMOTE

WORK COMPLETED DECEMBER 2020, JANUARY & FEBRUARY 2021

**82912 - 6010101 - 149090- 730660 - 5469 - Ch. 21 - v# 7755 - li# 41132 - exp. 12/31/23**

*Jed Brun*

4/1/2022

complete electrical construction

"We hereby certify that the articles and services covered by this invoice were produced and performed in compliance with all applicable requirements of Section 6, 7 and 12 of the Fair Labor Standards Act, as amended, and of regulations and orders of the United States Department of Labor issued under Section 14 thereof."



**MOTOR CITY ELECTRIC TECHNOLOGIES INC.**

AUTOMATION AND CONTROLS SOLUTIONS

9440 GRINNELL

DETROIT, MI 48213-1151

PHONE (313) 921-5300 FAX (313) 921-5310

"AN EQUAL OPPORTUNITY EMPLOYER"

# INVOICE

OMID  
ONE PUBLIC WORKS DRIVE, BUILDING 95  
WATERFORD, MI 48328-

Customer  
PO Number

Job Number	Sub Job	Contract Number	Date Performed	Application	
				Date	Number
921567	0	001	6/30/2021	7/28/2021	93770

SID LOCKHART

Item No	Description of Work	Contract Amount	Previous Billings	Current Amount	To Date Complete & Stored	Balance To Finish	Current Retainage
001	NESP SCADA CUTOVER	\$90.00	-	\$90.00	\$90.00	-	-
<b>Totals:</b>		<b>\$90.00</b>		<b>\$90.00</b>	<b>\$90.00</b>		
Less Retained:				-			
<b>Invoice Total:</b>				<b>\$90.00</b>			

AS NEEDED ELECTRICAL AND ENGINEERING SERVICE

SEE ATTACHED INVOICE SUMMARY AND FIELD REPORT

WORK ORDER #290

WORK COMPLETED 6/30/2021

*TM* 9-15-21

**82912 - 6010101 - 149090- 730660 - 5469 - Ch. 21 - v# 7755 - li#**

**41132 - exp. 12/31/23**

*JL Ben*

4/1/2022

complete electrical construction

"We hereby certify that the articles and services covered by this invoice were produced and performed in compliance with all applicable requirements of Section 6, 7 and 12 of the Fair Labor Standards Act, as amended, and of regulations and orders of the United States Department of Labor issued under Section 14 thereof."



**MOTOR CITY ELECTRIC TECHNOLOGIES INC.**

AUTOMATION AND CONTROLS SOLUTIONS

9440 GRINNELL

DETROIT, MI 48213-1151

PHONE (313) 921-5300 FAX (313) 921-5310

"AN EQUAL OPPORTUNITY EMPLOYER"

# INVOICE

OMID  
ONE PUBLIC WORKS DRIVE, BUILDING 95  
WATERFORD, MI 48328-

Customer  
PO Number

Job Number	Sub Job	Contract Number	Date Performed	Application	
				Date	Number
921567	0	001	7/7/2021	7/30/2021	93799

SID LOCKHART

Item No	Description of Work	Contract Amount	Previous Billings	Current Amount	To Date Complete & Stored	Balance To Finish	Current Retainage
001	NESP SCADA CUTOVER	\$180.00	-	\$180.00	\$180.00	-	-
<b>Totals:</b>		<b>\$180.00</b>		<b>\$180.00</b>	<b>\$180.00</b>		
Less Retained:				-			
<b>Invoice Total:</b>				<b>\$180.00</b>	<i>TM</i> 1-31-22		

AS NEEDED ELECTRICAL AND ENGINEERING SERVICE

SEE ATTACHED INVOICE SUMMARY AND FIELD REPORT

WORK PERFORMED 7/7/2021

**82912 - 6010101 - 149090- 730660 - 5469 - Ch. 21 - v# 7755 - li# 41132 - exp. 12/31/23**

4/1/2022

complete electrical construction

"We hereby certify that the articles and services covered by this invoice were produced and performed in compliance with all applicable requirements of Section 6, 7 and 12 of the Fair Labor Standards Act, as amended, and of regulations and orders of the United States Department of Labor issued under Section 14 thereof."



**MOTOR CITY ELECTRIC TECHNOLOGIES INC.**

AUTOMATION AND CONTROLS SOLUTIONS

9440 GRINNELL

DETROIT, MI 48213-1151

PHONE (313) 921-5300 FAX (313) 921-5310

"AN EQUAL OPPORTUNITY EMPLOYER"

# INVOICE

OMID  
ONE PUBLIC WORKS DRIVE, BUILDING 95  
WATERFORD, MI 48328-

Customer  
PO Number

Job Number	Sub Job	Contract Number	Date Performed	Application	
				Date	Number
921567	0	001	6/30/2021	7/30/2021	93803

SID LOCKHART

Item No	Description of Work	Contract Amount	Previous Billings	Current Amount	To Date Complete & Stored	Balance To Finish	Current Retainage
001	NESP SCADA CUTOVER	\$90.00	-	\$90.00	\$90.00	-	-
<b>Totals:</b>		<b>\$90.00</b>		<b>\$90.00</b>	<b>\$90.00</b>		
Less Retained:				-			
<b>Invoice Total:</b>				<b>\$90.00</b>	<i>TM</i>		

1-31-22

AS NEEDED ELECTRICAL AND ENGINEERING SERVICE

SEE ATTACHED INVOICE SUMMARY AND FIELD REPORT

**82912 - 6010101 - 149090- 730660 - 5469 - Ch. 21 - v# 7755 - li# 41132 - exp. 12/31/23**

WORK PERFORMED 6/30/2021

4/1/2022

complete electrical construction

"We hereby certify that the articles and services covered by this invoice were produced and performed in compliance with all applicable requirements of Section 6, 7 and 12 of the Fair Labor Standards Act, as amended, and of regulations and orders of the United States Department of Labor issued under Section 14 thereof."



**MOTOR CITY ELECTRIC TECHNOLOGIES INC.**

AUTOMATION AND CONTROLS SOLUTIONS

9440 GRINNELL

DETROIT, MI 48213-1151

PHONE (313) 921-5300 FAX (313) 921-5310

"AN EQUAL OPPORTUNITY EMPLOYER"

# INVOICE

OMID  
ONE PUBLIC WORKS DRIVE, BUILDING 95  
WATERFORD, MI 48328-

Customer  
PO Number

Job Number	Sub Job	Contract Number	Date Performed	Application	
				Date	Number
922567	0	001	11/4/2021	12/2/2021	94071

SID LOCKHART

Item No	Description of Work	Contract Amount	Previous Billings	Current Amount	To Date Complete & Stored	Balance To Finish	Current Retainage
001	NESP SCADA CUTOVER	\$846.00	-	\$846.00	\$846.00	-	-
<b>Totals:</b>		<b>\$846.00</b>		<b>\$846.00</b>	<b>\$846.00</b>		
Less Retained:				-			
<b>Invoice Total:</b>				<b>\$846.00</b>			

AS NEEDED ELECTRICAL AND ENGINEERING SERVICE

SEE ATTACHED INVOICE SUMMARY AND FIELD REPORT

WORK PERFORMED 11/4/2021

**82912 - 6010101 - 149090- 730660 - 5469 - Ch. 21 - v# 7755 - li# 41132 - exp. 12/31/23**

4/1/2022

*TM* 3-29-22

complete electrical construction

"We hereby certify that the articles and services covered by this invoice were produced and performed in compliance with all applicable requirements of Section 6, 7 and 12 of the Fair Labor Standards Act, as amended, and of regulations and orders of the United States Department of Labor issued under Section 14 thereof."



**MOTOR CITY ELECTRIC TECHNOLOGIES INC.**

AUTOMATION AND CONTROLS SOLUTIONS

9440 GRINNELL

DETROIT, MI 48213-1151

PHONE (313) 921-5300 FAX (313) 921-5310

"AN EQUAL OPPORTUNITY EMPLOYER"

# INVOICE

OMID  
ONE PUBLIC WORKS DRIVE, BUILDING 95  
WATERFORD, MI 48328-

Customer  
PO Number

Job Number	Sub Job	Contract Number	Date Performed	Application	
				Date	Number
922567	0	001	11/5/2021	12/2/2021	94072

SID LOCKHART

Item No	Description of Work	Contract Amount	Previous Billings	Current Amount	To Date Complete & Stored	Balance To Finish	Current Retainage
001	NESP SCADA CUTOVER	\$315.00	-	\$315.00	\$315.00	-	-
<b>Totals:</b>		<b>\$315.00</b>		<b>\$315.00</b>	<b>\$315.00</b>		
Less Retained:				-			
<b>Invoice Total:</b>				<b>\$315.00</b>			

AS NEEDED ELECTRICAL AND ENGINEERING SERVICE

SEE ATTACHED INVOICE SUMMARY AND FIELD REPORT

**82912 - 6010101 - 149090- 730660 - 5469 - Ch. 21 - v# 7755 - li# 41132 - exp. 12/31/23**

WORK PERFORMED 11/5/2021

4/1/2022

*TM* 3-29-22

complete electrical construction

"We hereby certify that the articles and services covered by this invoice were produced and performed in compliance with all applicable requirements of Section 6, 7 and 12 of the Fair Labor Standards Act, as amended, and of regulations and orders of the United States Department of Labor issued under Section 14 thereof."



**MOTOR CITY ELECTRIC TECHNOLOGIES INC.**

AUTOMATION AND CONTROLS SOLUTIONS

9440 GRINNELL

DETROIT, MI 48213-1151

PHONE (313) 921-5300 FAX (313) 921-5310

"AN EQUAL OPPORTUNITY EMPLOYER"

# INVOICE

OMID  
ONE PUBLIC WORKS DRIVE, BUILDING 95  
WATERFORD, MI 48328-

Customer  
PO Number

Job Number	Sub Job	Contract Number	Date Performed	Application	
				Date	Number
922567	0	001	11/10/2021	12/2/2021	94073

SID LOCKHART

Item No	Description of Work	Contract Amount	Previous Billings	Current Amount	To Date Complete & Stored	Balance To Finish	Current Retainage
001	NESP SCADA CUTOVER	\$180.00	-	\$180.00	\$180.00	-	-
<b>Totals:</b>		<b>\$180.00</b>		<b>\$180.00</b>	<b>\$180.00</b>		
Less Retained:				-			
<b>Invoice Total:</b>				<b>\$180.00</b>			

AS NEEDED ELECTRICAL AND ENGINEERING SERVICE

SEE ATTACHED INVOICE SUMMARY AND FIELD REPORT

**82912 - 6010101 - 149090- 730660 - 5469 - Ch. 21 - v# 7755 - li# 41132 - exp. 12/31/23**

WORK PERFORMED 11/10/2021

*TM* 3-29-22

4/1/2022

complete electrical construction

"We hereby certify that the articles and services covered by this invoice were produced and performed in compliance with all applicable requirements of Section 6, 7 and 12 of the Fair Labor Standards Act, as amended, and of regulations and orders of the United States Department of Labor issued under Section 14 thereof."





**MOTOR CITY ELECTRIC TECHNOLOGIES INC.**

AUTOMATION AND CONTROLS SOLUTIONS

9440 GRINNELL

DETROIT, MI 48213-1151

PHONE (313) 921-5300 FAX (313) 921-5310

"AN EQUAL OPPORTUNITY EMPLOYER"

# INVOICE

OMID  
ONE PUBLIC WORKS DRIVE, BUILDING 95  
WATERFORD, MI 48328-

Customer  
PO Number

Job Number	Sub Job	Contract Number	Date Performed	Application	
				Date	Number
922567	0	001	12/17/2021	1/4/2022	94153

SID LOCKHART

Item No	Description of Work	Contract Amount	Previous Billings	Current Amount	To Date Complete & Stored	Balance To Finish	Current Retainage
001	NESP SCADA CUTOVER	\$180.00	-	\$180.00	\$180.00	-	-
<b>Totals:</b>		<b>\$180.00</b>		<b>\$180.00</b>	<b>\$180.00</b>		
Less Retained:				-			
<b>Invoice Total:</b>				<b>\$180.00</b>			

AS NEEDED ELECTRICAL AND ENGINEERING SERVICE

**82912 - 6010101 - 149090- 730660 - 5469 - Ch. 21 - v# 7755 - li# 41132 - exp. 12/31/23**

SEE ATTACHED INVOICE SUMMARY AND FIELD REPORT

4/1/2022

WORK PERFORMED 12/17/2021

3-29-22

complete electrical construction

"We hereby certify that the articles and services covered by this invoice were produced and performed in compliance with all applicable requirements of Section 6, 7 and 12 of the Fair Labor Standards Act, as amended, and of regulations and orders of the United States Department of Labor issued under Section 14 thereof."



**MOTOR CITY ELECTRIC TECHNOLOGIES INC.**

AUTOMATION AND CONTROLS SOLUTIONS

9440 GRINNELL

DETROIT, MI 48213-1151

PHONE (313) 921-5300 FAX (313) 921-5310

"AN EQUAL OPPORTUNITY EMPLOYER"

# INVOICE

OMID  
ONE PUBLIC WORKS DRIVE, BUILDING 95  
WATERFORD, MI 48328-

Customer  
PO Number

Job Number	Sub Job	Contract Number	Date Performed	Application	
				Date	Number
922567	0	001	1/21/2022	2/2/2022	94244

SID LOCKHART

Item No	Description of Work	Contract Amount	Previous Billings	Current Amount	To Date Complete & Stored	Balance To Finish	Current Retainage
001	NESP SCADA CUTOVER	\$90.00	-	\$90.00	\$90.00	-	-
<b>Totals:</b>		<b>\$90.00</b>		<b>\$90.00</b>	<b>\$90.00</b>		
Less Retained:				-			
<b>Invoice Total:</b>				<b>\$90.00</b>			

AS NEEDED ELECTRICAL AND ENGINEERING SERVICE

SEE ATTACHED INVOICE SUMMARY AND FIELD REPORT

**82912 - 6010101 - 149090- 730660 - 5469 - Ch. 21 - v# 7755 - li# 41132 - exp. 12/31/23**

WORK PERFORMED 1/21/2022

*T.M.* 3-29-22

*Jed Ben* 4/1/2022

complete electrical construction

"We hereby certify that the articles and services covered by this invoice were produced and performed in compliance with all applicable requirements of Section 6, 7 and 12 of the Fair Labor Standards Act, as amended, and of regulations and orders of the United States Department of Labor issued under Section 14 thereof."



**MOTOR CITY ELECTRIC TECHNOLOGIES INC.**

AUTOMATION AND CONTROLS SOLUTIONS

9440 GRINNELL

DETROIT, MI 48213-1151

PHONE (313) 921-5300 FAX (313) 921-5310

"AN EQUAL OPPORTUNITY EMPLOYER"

# INVOICE

OMID  
ONE PUBLIC WORKS DRIVE, BUILDING 95  
WATERFORD, MI 48328-

Customer  
PO Number

Job Number	Sub Job	Contract Number	Date Performed	Application	
				Date	Number
922567	0	001	1/3/2022	2/2/2022	94245

SID LOCKHART

Item No	Description of Work	Contract Amount	Previous Billings	Current Amount	To Date Complete & Stored	Balance To Finish	Current Retainage
001	NESP SCADA CUTOVER	\$45.00	-	\$45.00	\$45.00	-	-
<b>Totals:</b>		<b>\$45.00</b>		<b>\$45.00</b>	<b>\$45.00</b>		
Less Retained:				-			
<b>Invoice Total:</b>				<b>\$45.00</b>			

AS NEEDED ELECTRICAL AND ENGINEERING SERVICE

SEE ATTACHED INVOICE SUMMARY AND FIELD REPORT

WORK PERFORMED 1/3/2022

*T M* 3-29-22

**82912 - 6010101 - 149090- 730660 - 5469 - Ch. 21 - v# 7755 - li# 41132 - exp. 12/31/23**

*JL Ben* 4/1/2022

complete electrical construction

"We hereby certify that the articles and services covered by this invoice were produced and performed in compliance with all applicable requirements of Section 6, 7 and 12 of the Fair Labor Standards Act, as amended, and of regulations and orders of the United States Department of Labor issued under Section 14 thereof."



**MOTOR CITY ELECTRIC TECHNOLOGIES INC.**

AUTOMATION AND CONTROLS SOLUTIONS

9440 GRINNELL

DETROIT, MI 48213-1151

PHONE (313) 921-5300 FAX (313) 921-5310

"AN EQUAL OPPORTUNITY EMPLOYER"

# INVOICE

OMID  
ONE PUBLIC WORKS DRIVE, BUILDING 95  
WATERFORD, MI 48328-

Customer  
PO Number

Job Number	Sub Job	Contract Number	Date Performed	Application	
				Date	Number
922567	0	001	1/24/2022	3/3/2022	94321

SID LOCKHART

Item No	Description of Work	Contract Amount	Previous Billings	Current Amount	To Date Complete & Stored	Balance To Finish	Current Retainage
001	NESP SCADA CUTOVER	\$90.00	-	\$90.00	\$90.00	-	-
<b>Totals:</b>		<b>\$90.00</b>		<b>\$90.00</b>	<b>\$90.00</b>		
Less Retained:				-			
<b>Invoice Total:</b>				<b>\$90.00</b>			

AS NEEDED ELECTRICAL AND ENGINEERING SERVICE

SEE ATTACHED INVOICE SUMMARY AND FIELD REPORT

**82912 - 6010101 - 149090- 730660 - 5469 - Ch. 21 - v# 7755 - li# 41132 - exp. 12/31/23**

WORK PERFORMED 1/24/2022

4/1/2022

3-29-22

complete electrical construction

"We hereby certify that the articles and services covered by this invoice were produced and performed in compliance with all applicable requirements of Section 6, 7 and 12 of the Fair Labor Standards Act, as amended, and of regulations and orders of the United States Department of Labor issued under Section 14 thereof."



**MOTOR CITY ELECTRIC TECHNOLOGIES INC.**

AUTOMATION AND CONTROLS SOLUTIONS

9440 GRINNELL

DETROIT, MI 48213-1151

PHONE (313) 921-5300 FAX (313) 921-5310

"AN EQUAL OPPORTUNITY EMPLOYER"

# INVOICE

OMID  
ONE PUBLIC WORKS DRIVE, BUILDING 95  
WATERFORD, MI 48328-

Customer  
PO Number

Job Number	Sub Job	Contract Number	Date Performed	Application	
				Date	Number
922567	0	001	3/29/2022	4/6/2022	94388

SID LOCKHART

Item No	Description of Work	Contract Amount	Previous Billings	Current Amount	To Date Complete & Stored	Balance To Finish	Current Retainage
001	NESP SCADA CUTOVER	\$180.00	-	\$180.00	\$180.00	-	-
<b>Totals:</b>		<b>\$180.00</b>		<b>\$180.00</b>	<b>\$180.00</b>		
Less Retained:				-			
<b>Invoice Total:</b>				<b>\$180.00</b>			

AS NEEDED ELECTRICAL AND ENGINEERING SERVICE

SEE ATTACHED INVOICE SUMMARY AND FIELD REPORT

**82912 - 6010101 - 149090- 730660 - 5469 - Ch. 21 - v#  
7755 - li# 41132 - exp. 12/31/23**

WORK PERFORMED 3/29 - WORK ORDER #00587

4/13/2022

*JM 4-6-22* *Jed Ben*

complete electrical construction

"We hereby certify that the articles and services covered by this invoice were produced and performed in compliance with all applicable requirements of Section 6, 7 and 12 of the Fair Labor Standards Act, as amended, and of regulations and orders of the United States Department of Labor issued under Section 14 thereof."



**MOTOR CITY ELECTRIC TECHNOLOGIES INC.**  
AUTOMATION AND CONTROLS SOLUTIONS  
 9440 GRINNELL  
 DETROIT, MI 48213-1151  
 PHONE (313) 921-5300 FAX (313) 921-5310  
 "AN EQUAL OPPORTUNITY EMPLOYER"

# INVOICE

OMID  
 ONE PUBLIC WORKS DRIVE, BUILDING 95  
 WATERFORD, MI 48328-

Customer  
 PO Number

Job Number	Sub Job	Contract Number	Date Performed	Application	
				Date	Number
922567	0	001	4/4/2022	4/6/2022	94389

SID LOCKHART

Item No	Description of Work	Contract Amount	Previous Billings	Current Amount	To Date Complete & Stored	Balance To Finish	Current Retainage
001	NESP SCADA CUTOVER	\$810.90	-	\$810.90	\$810.90	-	-
<b>Totals:</b>		<b>\$810.90</b>		<b>\$810.90</b>	<b>\$810.90</b>		
Less Retained:							
<b>Invoice Total:</b>				<b>\$810.90</b>			

MATERIAL ONLY -- CREATE BADGES

WORK ORDER 00605

**82912 - 6010101 - 149090- 730660 - 5469 - Ch. 21 - v# 7755 - li# 41132 - exp. 12/31/23**

*TM 4-6-22*

*JL B...*

4/13/2022

complete electrical construction

"We hereby certify that the articles and services covered by this invoice were produced and performed in compliance with all applicable requirements of Section 6, 7 and 12 of the Fair Labor Standards Act, as amended, and of regulations and orders of the United States Department of Labor issued under Section 14 thereof."



**NTH Consultants, Ltd.**  
Infrastructure Engineering  
and Environmental Services

**82912- 6010101- 149662-730639- 2603 - Ch.21 - v# 4716 -  
li #24138 - exp. 12/31/23**

4/14/22

OMI Drain Drainage District  
One Public Works Drive  
Building 95 West  
Waterford, MI 48328

Invoice # : 3  
Project : 61210495  
Invoice Group :  
Invoice Date : 4/6/2022

Attention Sid Lockhart

For Professional Services Rendered from **2/19/2022** - **3/25/2022**

Additional OMID NESPS Maintenance Engineering Services

Task 01	NESPS Health and Safety Audit	\$16,137.00
Task 02	Control Structure 6 (CS-6) Emergency Bypass System Design	\$39,643.00
Task 03	Wet Wall Screen Cleaning Equipment	\$17,069.00

Preliminary Budget Amount **\$72,849.00**  
Percent Complete: 57.14%

Analysis of Costs	This Invoice	Cumulative
Direct Salaries	\$ 2,544.30	\$ 8,300.92
Overhead %	188.00 4,783.28	15,605.72
Total Regular Labor Expense	7,327.58	23,906.64
<b>Total Direct Labor</b>	<b>7,327.58</b>	<b>23,906.64</b>
<b>Profit / Fixed Fee %</b>	<b>12.00 879.31</b>	<b>2,868.80</b>
Direct Expenses Charge	117.24	275.65
Expense Multiplier %	5.00 5.86	13.79
Direct Subcontractor Charge	1,382.00	13,738.10
Subcontractor/Subconsultant Multiplier %	6.00 82.92	824.29
<b>Total Other Direct Charges Reimbursables</b>	<b>1,588.02</b>	<b>14,851.83</b>
<b>Total Costs:</b>	<b>9,794.91</b>	<b>41,627.27</b>
<b>Total Due This Invoice</b>	<b>\$ 9,794.91</b>	<b>\$ 41,627.27</b>



**NTH Consultants, Ltd.**  
 Infrastructure Engineering  
 and Environmental Services

**82912 - 6010101 - 149662 - 731458- 2603 - Ch. 21 - v#238 -  
 li#24138 - exp. 12/31/23**

Omi Drain Drainage District  
 One Public Works Drive  
 Building 95 West  
 Waterford, MI 48328

Invoice # : 8  
 Project : 61210124  
 Invoice Group : \*\*  
 Invoice Date : 4/6/2022

Attention Sid Lockhart

For Professional Services Rendered from 2/19/2022 - 3/25/2022

Consulting Services Regarding 2021 OMID System Inspection

Task 01 Inspection and Reporting \$526,974.00  
 Preliminary Budget Amount \$526,974.00  
 Percent Complete: 48.33%

Analysis of Costs	This Invoice	Cumulative
Direct Salaries	\$ 512.93	\$ 14,712.89
Overhead %	188.00 964.31	27,660.23
Total Regular Labor Expense	1,477.24	42,373.12
<b>Total Direct Labor</b>	<b>1,477.24</b>	<b>1,477.24</b>
<b>Profit / Fixed Fee %</b>	<b>12.00 177.27</b>	<b>5,084.77</b>
Direct Expenses Charge	11.05	855.92
Expense Multiplier %	5.00 0.55	42.82
Direct Subcontractor Charge	2,019.06	194,661.22
Subcontractor/Subconsultant Multiplier %	6.00 121.14	11,679.68
Direct Unit Rate Charge	0.00	0.00
<b>Total Other Direct Charges Reimbursables</b>	<b>2,151.80</b>	<b>207,239.64</b>
<b>Total Costs:</b>	<b>3,806.31</b>	<b>254,697.53</b>
<b>Total Due This Invoice</b>	<b>\$ 3,806.31</b>	<b>\$ 254,697.53</b>





**84917 -6010101 -149015 -731444 - 2603 -1-3308- ch 21 v#4716  
- li#24138 - exp. 12/31/23**

OMI Drain Drainage District  
One Public Works Drive  
Building 95 West  
Waterford, MI 48328

Invoice # : 16  
Project : 61-200186  
Invoice Group : \*\*  
Invoice Date : 4/6/2022

Attentior Sid Lockhart

For Professional Services Rendered from **2/19/2022 - 3/25/2022**

Provide Engineering Services for OMID NI-EA Contract No.1 PCI-4 Rehabilitation Project and CS-9 Gate Installation Project D-425

Task 01	NI-EA OMID Contract No. 1 CCA	<b>\$2,257,657.77</b>
Task 02	OMID CS-9 Gate CCA	<b>\$217,468.00</b>
	Preliminary Budget Amount	<b>\$2,475,125.77</b>
	Percent Complete:	49.09%

Analysis of Costs		This Invoice	Cumulative
Direct Salaries	\$	29,084.04	\$ 212,286.16
Overhead %	188.00	54,677.99	399,097.98
Total Regular Labor Expense		83,762.03	611,384.14
<b>Total Direct Labor</b>		<b>83,762.03</b>	<b>611,384.14</b>
<b>Profit / Fixed Fee %</b>	<b>12.00</b>	<b>10,051.44</b>	<b>73,366.11</b>
Direct Expenses Charge		1,052.61	6,751.32
Expense Multiplier %	5.00	52.63	337.56
Direct Subcontractor Charge		31,594.10	493,601.82
Subcontractor/Subconsultant Multiplier %	6.00	1,895.65	29,616.15
Direct Unit Rate Charge		0.00	0.00
<b>Total Other Direct Charges Reimbursables</b>		<b>34,594.99</b>	<b>530,306.85</b>
<b>Total Costs:</b>		<b>128,408.46</b>	<b>1,215,057.10</b>
<b>Total Due This Invoice</b>		<b>\$ 128,408.46</b>	<b>\$ 1,215,057.10</b>



**84917- 6010101 - 149015 - 731458 - 2603 - 1-3309- ch 21  
- engcon v#4716 - li#24138 - exp. 12/31/23**

**OMI Drain Drainage District  
One Public Works Drive  
Building 95 West  
Waterford, MI 48328**

**Invoice # : 16  
Project : 61-200280  
Invoice Group : CMT  
Invoice Date : 4/6/2022**

**Attentior Sid Lockhart**

**For Professional Services Rendered from 2/19/2022 - 3/25/2022**

Provide Engineering and Consulting Services regarding NESPS Pumping and Electrical System Upgrade (D-421)

<b>Task 01</b>	<b>CMT Services</b>	<b>\$130,138.00</b>
<b>Task 02</b>	<b>Tnemec Coating Observation</b>	<b>\$0.00</b>
	<b>Preliminary Budget Amount</b>	<b>\$130,138.00</b>
	<b>Percent Complete:</b>	79.07%

Analysis of Costs	This Invoice	Cumulative
Direct Salaries	\$ 821.15	\$ 27,164.95
Overhead %	188.00 1,543.76	51,070.10
Total Regular Labor Expense	2,364.91	78,235.05
<b>Total Direct Labor</b>	<b>2,364.91</b>	<b>78,235.05</b>
<b>Profit / Fixed Fee %</b>	<b>12.00 283.79</b>	<b>9,388.21</b>
Direct Expenses Charge	47.62	14,541.62
Expense Multiplier %	5.00 2.38	727.09
Direct Subcontractor Charge	0.00	10.00
Subcontractor/Subconsultant Multiplier %	6.00 0.00	0.60
Direct Unit Rate Charge	0.00	0.00
<b>Total Other Direct Charges Reimbursables</b>	<b>50.00</b>	<b>15,279.31</b>
<b>Total Costs:</b>	<b>2,698.70</b>	<b>102,902.57</b>
<b>Total Due This Invoice</b>	<b>\$ 2,698.70</b>	<b>\$ 102,902.57</b>



**84917 - 6010101 - 149015 - 730639 - 2603 - 1-3308 - Ch.21**  
**v#4716 - li#24138 - exp. 12/31/23**

OMI Drain Drainage District  
One Public Works Drive  
Building 95 West  
Waterford, MI 48328

Invoice # : 34  
Project : 61-190078  
Invoice Group : NI-EA  
Invoice Date : 4/6/2022

Attention: Sid Lockhart

For Professional Services Rendered from

2/19/2022 - 3/25/2022

Engineering Design Services for Rehabilitation of NI-EA Sections PCI-4

Task 01	Project Management	\$276,159.00
Task 02	Condition Assessment	\$241,609.00
Task 03	Subsurface Utility Engineering	\$65,579.00
Task 04	Basemap Survey	\$89,327.00
Task 05	Geotechnical Investigation	\$134,797.00
Task 05A	7-Mile Utility Exploration/Design	\$0.00
Task 05B	Additional Geotech for PCI-4 Shaft	\$0.00
Task 06	Environmental Study	\$60,642.00
Task 07	Basis of Design	\$379,785.00
Task 08	Rehabilitation Design	\$282,099.00
Task 09	Contract Drawings	\$235,070.00
Task 10	Contract Specifications	\$188,178.00
Task 11	Construction Costs	\$27,761.00
Task 12	Permits & Coordination	\$25,655.00
Task 13	Bidding Assistance	\$198,402.00
Task 14	Gate Automation	\$68,770.00
Task 15	Odor & Air Flow Study	\$84,926.00

Preliminary Budget Amount \$2,358,759.00  
Percent Complete: 90.07%

Analysis of Costs	This Invoice	Cumulative
Direct Salaries	\$ 2,740.11	\$ 308,654.66
Overhead %	188.00 5,151.41	580,270.78
Total Regular Labor Expense	7,891.52	888,925.44
<b>Total Direct Labor</b>	<b>7,891.52</b>	<b>888,925.44</b>
<b>Profit / Fixed Fee %</b>	<b>12.00 946.98</b>	<b>106,671.04</b>
Direct Expenses Charge	7.14	27,671.41
Expense Multiplier %	5.00 0.36	1,383.61
Direct Subcontractor Charge	3,050.65	1,037,625.68
Subcontractor/Subconsultant Multiplier %	6.00 183.04	62,257.69
<b>Total Other Direct Charges Reimbursables</b>	<b>3,241.19</b>	<b>1,128,938.39</b>
<b>Total Costs:</b>	<b>12,079.69</b>	<b>2,124,534.87</b>
<b>Total Due This Invoice</b>	<b>\$ 12,079.69</b>	<b>\$ 2,124,534.87</b>



**NTH Consultants, Ltd.**  
Infrastructure Engineering  
and Environmental Services

**82912 - 149090 - 730639 - 2603 - Ch 21 - v#4716**  
**exp. 12/31/23 li#24138**

4/14/22

OMI Drain Drainage District  
One Public Works Drive  
Building 95 West  
Waterford, MI 48328

Invoice # : 63  
Project : 61-210313  
Invoice Group : \*\*  
Invoice Date : 4/6/2022

Attention Sid Lockhart

For Professional Services Rendered from **2/19/2022** - **3/25/2022**

Consulting Services Regarding Additional OMID Rehabilitation Program 2021 Closeout Services and As-Needed NESPS Maintenance Tasks

Task 01	Contract 3 NESPS Rehab Closeout	\$9,563.00
Task 02	PCI-4 Liner Deterioration Closeout	\$10,939.00
Task 03	Discharge Pipe Coating Rehabilitation	\$27,930.00
Task 04	NESPS Wet Well Sediment Survey	\$19,639.00
	<b>Preliminary Budget Amount</b>	<b>\$68,071.00</b>
	<b>Percent Complete:</b>	57.77%

		This Invoice	Cumulative
<b>Analysis of Costs</b>			
Direct Salaries		\$ 1,566.73	\$ 7,675.68
Overhead %	188.00	2,945.45	14,430.28
Total Regular Labor Expense		4,512.18	22,105.96
<b>Total Direct Labor</b>		<b>4,512.18</b>	<b>22,105.96</b>
<b>Profit / Fixed Fee %</b>	12.00	<b>541.46</b>	2,652.71
Direct Expenses Charge		0.00	0.00
Expense Multiplier %	5.00	0.00	0.00
Direct Subcontractor Charge		0.00	13,872.15
Subcontractor/Subconsultant Multiplier %	5.00	0.00	693.61
<b>Total Other Direct Charges Reimbursables</b>		<b>0.00</b>	<b>14,565.76</b>
<b>Total Costs:</b>		<b>5,053.65</b>	<b>39,324.43</b>
<b>Total Due This Invoice</b>		<b>\$ 5,053.64</b>	<b>\$ 39,324.43</b>

**OMID Task Breakdown Worksheet**

**NEW** NTH Project # 61-210313 Consulting Services Regarding Additional OMID Rehabilitation Program 2021 Closeout Services and As-Needed NESPS Maintenance Tasks

**INVOICE NUMBER:** 63

**INVOICE DATE:** 4/6/2022

<u>OMID Task No.</u>	<u>Task Description</u>	<u>Work Order</u>	<u>Current Invoice</u>		<u>OMID Preliminary Budget</u>	<u>Amount Invoiced To Date</u>	<u>Fees This Invoice</u>	<u>Cumulative Amount Invoiced</u>	<u>Budget Amount Remaining</u>
			<u>Numbers for Each Task</u>						
01	Contract 3 NESPS Rehab Closeout	D-432	629130		\$9,563.00	\$10,607.64	2,186.11	\$12,793.75	(\$3,230.75)
02	PCI-4 Liner Deterioration Closeout	D-432	629130		\$10,939.00	\$3,861.13	1,392.40	\$5,253.53	\$5,685.47
03	Discharge Pipe Coating Rehabilitation	D-432	629130		\$27,930.00	\$9,614.26	1,475.13	\$11,089.39	\$16,840.61
04	NESPS Wet Well Sediment Survey	D-432	-		\$19,639.00	\$10,187.76	-	\$10,187.76	\$9,451.24
<b>Totals:</b>					<b>\$68,071.00</b>	<b>\$34,270.79</b>	<b>5,053.64</b>	<b>\$39,324.43</b>	<b>\$28,746.57</b>
<b>Balance Due</b>							<b>\$5,053.64</b>		

**OLD** NTH Project # 61-150162 NESPS Discharge Chamber CCA

**INVOICE NUMBER:** 01 thru 56

<u>OMID Task No.</u>	<u>Task Description</u>	<u>Work Order</u>	<u>Current Invoice</u>		<u>OMID Preliminary Budget</u>	<u>Amount Invoiced To Date</u>	<u>Fees This Invoice</u>	<u>Cumulative Amount Invoiced</u>	<u>Budget Amount Remaining</u>
			<u>Numbers for Each Task</u>						
01	CCA / Construction Observation (Task 01)	D-367	-		\$437,458.04	\$437,458.04	-	\$437,458.04	\$0.00
02	CIP Concrete Riser Substitution (Task 02)	D-367	-		\$3,041.52	\$3,041.52	-	\$3,041.52	\$0.00
03	Continuation of NESPS CCA (Task 03)	D-379							
		D-385							
		D-391							
		D-396							
		D-399							
		D-407	-		\$522,070.69	\$522,062.24	-	\$522,062.24	\$8.45
04	Continuation of GLWA Coordination (Task 04)	D-391							
		D-396							
		D-399	-		\$41,800.92	\$41,800.92	-	\$41,800.92	\$0.00
05	Sterling Heights Sewer Grout Investigation (Task 05)	D-396	-		\$7,507.83	\$7,487.88	-	\$7,487.88	\$19.95
<b>Totals:</b>					<b>\$1,011,879.00</b>	<b>\$1,011,850.60</b>	<b>-</b>	<b>\$1,011,850.60</b>	<b>\$28.40</b>

Oakland Macomb Interceptor Drain Drainage District  
OMID NESPS Project Closeout 2021  
NESPS Discharge Chamber CCA  
P R O G R E S S  
R E P O R T

From February 19, 2022 through March 25, 2022

Progress by NTH Consultants, Ltd. and Subconsultants/Subcontractors

Contract 3 NESPS Rehab  
Closeout (NTH Project  
No. 61-210313 - Task 01)

Work Progress

- Coordinated meetings among Engineer, Contractor, and Owner to discuss OMID Contract 3 project closeout
- SRF funding documentation closeout requested by EGLE
- Prepared monthly invoice including WBE/MBE report, and progress report.

Deliverables

- None

Plans for Next Reporting Period

- None

PCI-4 Liner Deterioration  
Closeout (NTH Project  
No. 61-210313 - Task 02)

Work Progress

- SRF funding documentation closeout requested by EGLE
- Coordinated meetings to discuss PCI-4 liner deterioration issues and closeout
- Reviewed the evaluation report by prepared Eco-Cast Manufacturer.

Deliverables

- None

Plans for Next Reporting Period

- Continue to coordinate meetings to discuss PCI-4 liner deterioration issues and closeout

Discharge Pipe Coating  
Rehabilitation  
(NTH Project No. 61-  
210313 - Task 03)

Work Progress

- Coordinated meetings among Engineer, Contractor, and Owner to discuss Tnemec coating issues
- Prepared a draft “Request for Technical Submission” document to gather info. on coating technologies and distributed for internal review and incorporated comments.

Deliverables

- Draft “Request for Technical Submission”

---

NESPS Wet Well  
Sediment Survey  
(NTH Project No. 61-  
210313 - Task 04)

Plans for Next Reporting Period

- Coordinate work related to repairs with Themec coating failure.
- Coordinate meetings among Engineer, Contractor, and Owner to discuss project closeout.
- Finalize the “Request for Technical Submission” and issue to coating/liner manufacturers

Work Progress

- None

Deliverables

- None

Plans for Next Reporting Period

- Continue monthly NESPS Wetwell sediment survey by AEW
-

## Commentary and Information Pertaining to the Invoice Including a Summary of Outstanding Charges

Invoice No. 63

April 7, 2022

Invoice Period: February 19, 2022 through March 25, 2022

Project No. 61-210313  
OMID NESPS Project  
Closeout 2021  
(Old #61-150612)  
NESPS Discharge  
Chamber Rehabilitation

The following is a summary of commentary and information pertaining to the invoice, including a summary of outstanding charges:

1. Some miscellaneous NTH and subconsultant direct expense and unit rate charges were not included due to internal timing of expense submittals.
2. Budgets were adjusted among individual tasks/phases within the project to reflect actual charges incurred; however no change was made to the approved total project budget.
3. Engineering Work Order D-407 has been included in the budget.
4. Engineering Work Order D-432 has been included in the budget.



State Revolving Fund for Wastewater Projects  
Drinking Water Revolving Fund

**Project No.:** 5368-02

**SRF/DWRF Recipient Name and Address:** Oakland-Macomb Interceptor Drain Drainage District,  
One Public Works Drive, Building 95 West, Waterford, MI 48328

**Reported by:** Jeffrey S. Parrott (248) 452-2162

Procurement Made by SRF/DWRF Loan Recipient or Prime	Name & Address of MBE or WBE	MBE	WBE	\$ Amount	Type of Procurement	Date of Award
Construction Contract Administration (CCA) Consulting Engineers	Applied Science, Inc. 300 River Place Suite 5400 7380.82		X	\$ 65,687.65	3	5/1/2015
Reproductions	Hernandez Blueprinting Services, LLC 1401 Vermont Street Detroit, MI 48216	X		As Needed	3	1/1/2015

Type of Procurement Code: 1 Construction, 2 Supplies, 3 Services, 4 Equipment

Comments:

**Name of Authorized Representative:** Saju Sachidanandan, PE **Date:** 4/5/2022

**Signature of Authorized Representative:** SS

**Note:** If more space is needed to show additional MBEs or WBEs, please use second sheet.

Company Name	NTH Invoice #	Contractors Invoice Date	Amount	Invoice Totals	
Applied Science, Inc.	1	5/20/2015	\$806.74	6146	\$806.74
Applied Science, Inc.	1	6/24/2015	\$1,658.75	6303	\$1,658.75
Applied Science, Inc.	2	7/27/2015	\$2,823.58	6309	\$2,823.58
Applied Science, Inc.	3	8/19/2015	\$1,075.65	6327	\$1,075.65
Applied Science, Inc.	4	9/19/2015	\$2,218.52	6352	\$2,218.52
Applied Science, Inc.	5	10/22/2015	\$4,488.50	6371	\$4,488.50
Applied Science, Inc.	6	11/16/2015	\$2,746.74	6394	\$2,746.74
Applied Science, Inc.	7	12/16/2015	\$1,546.24	6415	\$1,546.24
Applied Science, Inc.	8	-	-	-	\$0.00
Applied Science, Inc.	9	2/16/2016	\$3,361.40	6462	\$3,361.40
Applied Science, Inc.	10	3/22/2016	\$2,016.84	6490	\$2,016.84
Applied Science, Inc.	11-12	-	-	-	\$0.00
Applied Science, Inc.	13	6/21/2016	\$5,625.20	6563	\$5,625.20
Applied Science, Inc.	14-18	-	-	-	\$0.00
Applied Science, Inc.	19	12/21/2016	\$4,898.04	6732	\$4,898.04
Applied Science, Inc.	19	1/24/2017	\$958.00	6770	\$958.00
Applied Science, Inc.	19	2/24/2017	\$1,599.07	6796	\$1,599.07
Applied Science, Inc.	20	3/21/2017	\$1,610.73	6824	\$1,610.73
Applied Science, Inc.	21	4/20/2017	\$1,934.52	6860	\$1,934.52
Applied Science, Inc.	22	-	-	-	-
Applied Science, Inc.	23	6/21/2017	\$1,259.50	6886	\$1,259.50
Applied Science, Inc.	24-63	-	-	-	-
<b>Total this Invoice and Previous Invoices</b>					<b>\$40,628.02</b>

**Applied Science, Inc. \$40,628.02**

Reproductions

Company Name	NTH Invoice #	Contractors Invoice Date	Amount	Invoice Totals	
Hernandez Blueprinting Services, LLC	1-63	-	\$0.00	-	\$0.00
<b>Total this Invoice and Previous Invoices</b>					<b>\$0.00</b>

**Hernandez Blueprinting Services, LLC \$0.00**

Contractor/Organization Name: Applied Science, Inc.

Payroll Month/Period	Total Labor Hours Worked	Monthly FTEs	Payroll Amount
January 18, 2015 to May 16, 2015	6	0.009	\$806.74
May 17, 2015 to June 20, 2015	12.5	0.063	\$1,658.75
June 21, 2015 to July 25, 2015	21	0.105	\$2,823.58
July 26, 2015 to August 15, 2015	8	0.067	\$1,075.65
August 16, 2015 to September 19, 2015	16.5	0.086	\$2,218.52
September 20, 2015 to October 17, 2015	38	0.238	\$4,488.50
October 18, 2015 to November 14, 2015	21	0.131	\$2,746.74
November 15, 2015 to December 12, 2015	11.5	0.072	\$1,546.24
December 13, 2015 to February 13, 2016	25	0.069	\$3,361.40
February 14, 2016 to March 19, 2016	15	0.075	\$2,016.84
March 20, 2016 to May 28, 2016	41	0.103	\$5,625.20
July 24, 2016 to December 17, 2016	39.5	0.047	\$4,898.04
December 18, 2016 to January 14, 2017	7.5	0.047	\$958.00
January 15, 2017 to February 18, 2017	12	0.060	\$1,599.07
February 19, 2017 to March 18, 2017	14.5	0.091	\$1,610.73
March 19, 2017 to April 15, 2017	17	0.106	\$1,934.52
April 16, 2017 to June 3, 2017	9	0.032	\$1,259.50
			\$40,628.02

FTE Calculation Period	# of Working Days in Period	# of Full Time Hours	Monthly FTEs
January 18, 2015 to May 16, 2015	85	680	0.009
May 17, 2015 to June 20, 2015	25	200	0.063
June 21, 2015 to July 25, 2015	25	200	0.105
July 26, 2015 to August 15, 2015	15	120	0.067
August 16, 2015 to September 19, 2015	24	192	0.086
September 20, 2015 to October 17, 2015	20	160	0.238
October 18, 2015 to November 14, 2015	20	160	0.131
November 15, 2015 to December 12, 2015	20	160	0.072
December 13, 2015 to February 13, 2016	45	360	0.069
February 14, 2016 to March 19, 2016	25	200	0.075
March 20, 2016 to May 28, 2016	50	400	0.103
July 24, 2016 to December 17, 2016	105	840	0.047
December 18, 2016 to January 14, 2017	20	160	0.047
January 15, 2017 to February 18, 2017	25	200	0.060
February 19, 2017 to March 18, 2017	20	160	0.091
March 19, 2017 to April 15, 2017	20	160	0.106
April 16, 2017 to June 3, 2017	35	280	0.032

**01 - Contract 3 NESPS Rehab Closeout****LABOR REVENUE TYPE CODE****Multiplier Labor***Class / Employee*

<i>Class / Employee</i>	<i>Date</i>	<i>Hours</i>	<i>Cost Rate</i>	<i>Amount</i>
<b>Administrative</b>				
Christine R. Pollitt	3/1/2022	0.750	33.6500	25.24
<b>Sr Principal Engineer</b>				
Lawrence T. Gilbert				
	3/7/2022	1.000	58.1700	58.17
	3/8/2022	1.500	58.1700	87.26
	3/11/2022	2.000	58.1700	116.34
	3/14/2022	1.000	58.1700	58.17
	3/16/2022	1.500	58.1700	87.26
	3/23/2022	1.000	58.1700	58.17
	3/25/2022	3.000	58.1700	174.51
		-----		-----
<b>Total Lawrence T. Gilbert</b>		11.000		639.88
<b>Total Sr Principal Engineer</b>		-----		-----
		11.000		639.88
<b>Word Processor</b>				
Marguerite A. McKiever				
	3/3/2022	0.250	25.2400	6.31
	3/4/2022	0.250	25.2400	6.31
		-----		-----
<b>Total Marguerite A. McKiever</b>		0.500		12.62
<b>Total Word Processor</b>		-----		-----
		0.500		12.62
			<b>Total Multiplier Labor</b>	<b>677.74</b>
<b>Total LABOR REVENUE TYPE CODE</b>				<b>677.74</b>
<b>Total Bill Task: 01 - Contract 3 NESPS Rehab Closeout</b>				<b>677.74</b>

**02 - PCI-4 Liner Deterioration Closeout****LABOR REVENUE TYPE CODE****Multiplier Labor***Class / Employee*

<i>Class / Employee</i>	<i>Date</i>	<i>Hours</i>	<i>Cost Rate</i>	<i>Amount</i>
<b>Sr Principal Engineer</b>				
Saju Sachidanandan				
	2/21/2022	0.500	65.6300	32.82
	3/1/2022	0.500	65.6300	32.82
		-----		-----
<b>Total Saju Sachidanandan</b>		1.000		65.64
<b>Total Sr Principal Engineer</b>		-----		-----
		1.000		65.64
<b>Sr Staff Professional</b>				
Zhiren Zhu				
	3/8/2022	5.500	34.8600	191.73
	3/14/2022	5.000	34.8600	174.30
		-----		-----
<b>Total Zhiren Zhu</b>		10.500		366.03
<b>Total Sr Staff Professional</b>		-----		-----
		10.500		366.03
			<b>Total Multiplier Labor</b>	<b>431.67</b>
<b>Total LABOR REVENUE TYPE CODE</b>				<b>431.67</b>
<b>Total Bill Task: 02 - PCI-4 Liner Deterioration Closeout</b>				<b>431.67</b>

**03 - Discharge Pipe Coating Rehabilitation****LABOR REVENUE TYPE CODE**

**Multiplier Labor**

Class / Employee

**Sr Principal Engineer**

Saju Sachidanandan

Date

Hours

Cost Rate

Amount

3/8/2022

0.750

65.6300

49.22

3/10/2022

0.500

65.6300

32.82

3/14/2022

0.500

65.6300

32.82

3/16/2022

0.500

65.6300

32.82

3/21/2022

0.500

65.6300

32.82

3/23/2022

0.500

65.6300

32.82

**Total Saju Sachidanandan**-----  
3.250-----  
213.32**Total Sr Principal Engineer**-----  
3.250-----  
213.32**Sr Proj Professional**

Abdulnasser Y. Almadhoun

2/21/2022

0.500

48.8000

24.40

2/22/2022

0.500

48.8000

24.40

2/23/2022

0.500

48.8000

24.40

2/24/2022

1.000

48.8000

48.80

2/25/2022

0.500

48.8000

24.40

3/8/2022

0.500

48.8000

24.40

3/9/2022

0.500

48.8000

24.40

3/17/2022

1.000

48.8000

48.80

**Total Abdulnasser Y. Almadhoun**-----  
5.000-----  
244.00**Total Sr Proj Professional**-----  
5.000-----  
244.00**Total Multiplier Labor****457.32****Total LABOR REVENUE TYPE CODE****457.32****Total Bill Task: 03 - Discharge Pipe Coating Rehabilitation****457.32**



**NTH Consultants, Ltd.**

Infrastructure Engineering  
and Environmental Services

41780 Six Mile Road  
Northville, MI 48168  
248.553.6300  
248.324.5179 Fax

Mr. Sid Lockhart, P.E.  
Oakland Macomb Interceptor Drain Drainage District  
One Public Works Drive, Bldg. 95 West  
Waterford, MI 48328-1907

April 07, 2022  
NTH Project No. 61-210313  
(Old #61-150162: Invoice #1 - #56)

RE: Engineering Services Agreement  
Oakland Macomb Interceptor  
OMID NESPS Project Closeout 2021/NESPS Discharge Chamber CCA – Invoice #63  
Invoice Period: February 19, 2022 through March 25, 2022  
Amount Due This Invoice: **\$5,053.64**

Dear Mr. Lockhart:

Attached is the NTH Consultants, Ltd (NTH) referenced invoice for services performed and subcontract invoices received from February 19, 2022 through March 25, 2022 under our Engineering Services Agreement with the Oakland Macomb Interceptor Drain Drainage District.

We have reviewed the invoice and believe it to be correct.

If you have any questions, please do not hesitate to contact us.

Sincerely,

NTH Consultants, Ltd

DocuSigned by:  
*Saju Sachidanandan*  
04261F17B85445C...  
Saju Sachidanandan, P.E.  
Sr. Principal Engineer

DocuSigned by:  
*Lawrence T. Gilbert*  
CC824AA61BE2419...  
Lawrence T. Gilbert, P.E.  
Construction Contract Administrator

SS/LTG/mlk

Attachments

cc: Stephen Downing  
Joel T. Brown, P.E



28294 Beck Road Wixom, MI 48393  
 800-419-5199 FAX (248) 374-6402  
 www.PMTech.org

# Invoice

Date **7/28/2021** Invoice # **0000155094**

**Bill To:**

County Of Oakland  
 A Michigan Constitutional Corp  
 2100 Pontiac Lake Road  
 Waterford MI 48328

**Site Address:**

Northeast Sewage Pumping Station - Generator  
 1  
 11001 East State Fair  
 Detroit MI 48234

PO Number	Terms	Make	Model	Serial Number
Darrin	NET 30 DAYS	CAT/KATO	A269500000	13669-05
KW	PM Tech's Other Locations		A LATE FEE of 1.5% per month, 18% per year of the unpaid balance will be added to past due amounts.	Remit To:
1825	2385 Wilshire Drive Jenison, MI 49428 1695 Dalton Drive New Carlisle, OH 45344			28294 Beck Road Wixom, MI 48393

DESCRIPTION	QTY	PRICE EACH	AMOUNT
-------------	-----	------------	--------

Quote 150782

LOWER BLOCK HEATER HOSE ASSY	1.00	104.27	104.27
Shop Surcharge	1.00	25.68	25.68
Technician labor.	1.00	513.50	513.50

7/23/21

*TM* 10-20-21

Fund	<u>82912</u>	Dept	<u>6010101</u>
Prog	<u>149090</u>	Acct	<u>730600</u>
Contract #	<u>5821</u>	Project	<u>/</u>
Chap 20/21	<u>21</u>	Op Unit	
Approver			

*JL Ben*

4/13/2022

Visa, Master Card, Discover or American Express 3% processing fee will be added to total over \$2,000	Subtotal	\$643.45
Sign: _____ Inv # _____	Sales Tax	\$0.00
Card #: _____	<b>Balance Due</b>	<b>\$643.45</b>
Exp Date: _____ Security Code: _____	This Invoice is for the Services mentioned above only, if other repair work was completed it will be invoiced separately.	

Conditions of Sale and Limitations of Liability are on back of invoice.  
 manufactures written warranty are the owner's responsibility to reimburse PM Technologies for reasonable costs incurred.

Warranty Disclaimer: parts and labor not covered by the



28294 Beck Road Wixom, MI 48393  
 800-419-5199 FAX (248) 374-6402  
 www.PMTech.org

# Invoice

Date **7/28/2021** Invoice # **0000155221**

**Bill To:**

County Of Oakland  
 A Michigan Constitutional Corp  
 2100 Pontiac Lake Road  
 Waterford MI 48328

**Site Address:**

Northeast Sewage Pumping Station - Generator  
 1  
 11001 East State Fair  
 Detroit MI 48234

PO Number	Terms	Make	Model	Serial Number
JEFF	NET 30 DAYS	CAT/KATO	A269500000	13669-05
<b>KW</b>	<b>PM Tech's Other Locations</b>		A LATE FEE of 1.5% per month, 18% per year, of the unpaid balance unpaid balance will be added to past due amounts	<b>Remit To:</b> 28294 Beck Road Wixom, MI 48393
1825	2385 Wilshire Drive Jenison, MI 49428 1695 Dalton Drive New Carlisle, OH 45344			

DESCRIPTION	QTY	PRICE EACH	AMOUNT																				
Service Call - customers are simulating a outage we are there if any issue	1.00	185.00	185.00																				
Labor	5.50	115.00	632.50																				
6/9/21																							
<i>TM</i> 10/27/21																							
<table border="1" style="margin: auto;"> <tr> <td>Fund</td><td><u>82912</u></td> <td>Dept</td><td><u>6010101</u></td> </tr> <tr> <td>Prog</td><td><u>149090</u></td> <td>Acct</td><td><u>7306100</u></td> </tr> <tr> <td>Contract #</td><td><u>5821</u></td> <td>Project</td><td><u>1</u></td> </tr> <tr> <td>Chap 20/21</td><td><u>21</u></td> <td>Op Unit</td><td>_____</td> </tr> <tr> <td>Approver</td><td colspan="3">_____</td> </tr> </table>				Fund	<u>82912</u>	Dept	<u>6010101</u>	Prog	<u>149090</u>	Acct	<u>7306100</u>	Contract #	<u>5821</u>	Project	<u>1</u>	Chap 20/21	<u>21</u>	Op Unit	_____	Approver	_____		
Fund	<u>82912</u>	Dept	<u>6010101</u>																				
Prog	<u>149090</u>	Acct	<u>7306100</u>																				
Contract #	<u>5821</u>	Project	<u>1</u>																				
Chap 20/21	<u>21</u>	Op Unit	_____																				
Approver	_____																						
<i>Ed Ben</i> 4/13/2022																							

Visa, Master Card, Discover or American Express 3% processing fee will be added to total over \$2,000  Sign: _____ Inv # _____  Card #: _____  Exp Date: _____ Security Code: _____	<b>Subtotal</b> \$817.50 <b>Sales Tax</b> \$0.00 <b>Balance Due</b> \$817.50  This Invoice if for the Services mentioned above only, if other repair work was completed it will be invoiced separately.
---	---

Conditions of Sale and Limitations of Liability are on back of invoice.  
 manufactures written warranty are the owner's responsibility to reimburse PM Technologies for reasonable costs incurred.

Warranty Disclaimer: parts and labor not covered by the





28294 Beck Road Wixom, MI 48393  
 800-419-5199 FAX (248) 374-6402  
 www.PMTech.org

# Invoice

Date **9/16/2021** Invoice # **0000157506**

**Bill To:**

County Of Oakland  
 A Michigan Constitutional Corp  
 2100 Pontiac Lake Road  
 Waterford MI 48328

**Site Address:**

Main Tab

PO Number	Terms	Make	Model	Serial Number	
contract	NET 30 DAYS				
<b>KW</b>	<b>PM Tech's Other Locations</b>		A LATE FEE of 1.5% per month, 18% per year of the unpaid balance will be added to past due amounts.	<b>Remit To:</b> 28294 Beck Road Wixom, MI 48393	
	2385 Wilshere Drive Jenison, MI 49428 1695 Dalton Drive New Carlisle, OH 45344				
DESCRIPTION			QTY	PRICE EACH	AMOUNT

SP-001 inspection for AST's located at OMIDD/Oakland County NESPS	2.00	500.00	1,000.00
	1.00		

Fund	33912	Dept	6010101
Prog	149090	Acct	730600
Contract #	5821	Project	1
Chap 20/21	21	Op Unit	
Approver			

*TM* 10-20-21

*JL Ben*

4/13/2022

Visa, Master Card, Discover or American Express 3% processing fee will be added to total over \$2,000  Sign: _____ Inv # _____  Card #: _____  Exp Date: _____ Security Code: _____	<b>Subtotal</b> \$1,000.00 <b>Sales Tax</b> \$0.00 <b>Balance Due</b> \$1,000.00 This Invoice is for the Services mentioned above only, if other repair work was completed it will be invoiced separately.
---	---

Conditions of Sale and Limitations of Liability are on back of invoice. Warranty Disclaimer: parts and labor not covered by the manufactures written warranty are the owner's responsibility to reimburse PM Technologies for reasonable costs incurred.



Oakland County Water Resources Commissioner  
Attn: Sid Lockhard, P.E.  
One Public Works Drive  
Building 95-West  
Waterford 48328

March 8, 2022

Invoice No: 03559.01 - 21

**84917 - 6010101 - 149015 - 731458- 6096- 1-3308 - ch21 - engcon - v#16918  
- exp. 5/29/23**

Project 03559.01 Oakland-Macomb Interceptor Drainage 2020

4/1/2022

**Professional Services from February 1, 2022 to February 28, 2022**

**Professional Personnel**

	<b>Hours</b>	<b>Rate</b>	<b>Amount</b>	
Zann, John	64.00	94.00	6,016.00	
Totals	64.00		6,016.00	
<b>Total Labor</b>				<b>6,016.00</b>

**Additional Fees**

Overhead	149.10 % of 6,016.00		8,969.86	
Profit	10.00 % of 14,985.86		1,498.59	
<b>Total Additional Fees</b>			<b>10,468.45</b>	<b>10,468.45</b>

**Billing Limits**

	<b>Current</b>	<b>Prior</b>	<b>To-Date</b>
Total Billings	16,484.45	184,419.69	200,904.14
Limit			450,000.00
Remaining			249,095.86

**Total this Invoice \$16,484.45**

Please remit payment to PMA CONSULTANTS LLC, PO BOX 675234, DETROIT, MI 48267-5234. Please direct any questions regarding this invoice to Samantha Zeisler, Project Administrator, at 734-418-7897 or szeisler@pmaconsultants.com



Oakland County Water Resources Commissioner  
Attn: Sid Lockhard, P.E.  
One Public Works Drive  
Building 95-West  
Waterford 48328

April 5, 2022  
Invoice No: 03559.01 - 22

**84917 - 6010101 - 149015 - 731458- 6096- 1-3308 - ch21 - engcon - v#16918  
- exp. 5/29/23**

Project 03559.01 Oakland-Macomb Interceptor Drainage 2020

4/13/2022

**Professional Services from March 1, 2022 to March 31, 2022**

**Professional Personnel**

	<b>Hours</b>	<b>Rate</b>	<b>Amount</b>	
Zann, John	48.00	94.00	4,512.00	
Totals	48.00		4,512.00	
<b>Total Labor</b>				<b>4,512.00</b>

**Additional Fees**

Overhead	149.10 % of 4,512.00		6,727.39	
Profit	10.00 % of 11,239.39		1,123.94	
<b>Total Additional Fees</b>			<b>7,851.33</b>	<b>7,851.33</b>

**Billing Limits**

	<b>Current</b>	<b>Prior</b>	<b>To-Date</b>	
Total Billings	12,363.33	200,904.14	213,267.47	
Limit			450,000.00	
Remaining			236,732.53	

**Total this Invoice \$12,363.33**

Please remit payment to PMA CONSULTANTS LLC, PO BOX 675234, DETROIT, MI 48267-5234. Please direct any questions regarding this invoice to Samantha Zeisler, Project Administrator, at 734-418-7897 or szeisler@pmaconsultants.com



**Rotor Electric Company of Michigan, LLC.**

9522 GRINNELL  
DETROIT, MI 48213-1151  
PHONE (313) 891-0331 FAX (313) 921-5310  
"AN EQUAL OPPORTUNITY EMPLOYER"

# INVOICE

OMID  
1 PUBLIC WORKS DRIVE  
WATERFORD, MI 48328-

**Customer  
PO Number**  
Professional Services Contrac

Job Number	Sub Job	Contract Number	Date Performed	Application	
				Date	Number
719707	0	001	1/12/2022	3/22/2022	12489

JOEL BROWN

Item No	Description of Work	Contract Amount	Previous Billings	Current Amount	To Date Complete & Stored	Balance To Finish	Current Retainage
001	SWITCHGEAR MAINTENANCE AND TESTING	\$5,325.98	-	\$5,325.98	\$5,325.98	-	-
<b>Totals:</b>		<b>\$5,325.98</b>		<b>\$5,325.98</b>	<b>\$5,325.98</b>		
Less Retained:				-			
<b>Invoice Total:</b>				<b>\$5,325.98</b>			

PUMP P4, P5, P6 MOTOR MAINTENANCE

WO 491

**82912 - 6010101 - 149090 - 730660 - 5807 - Ch. 21 - v#22125 - li#42614 - exp. 6/28/22**

4/1/2022

3-23-22

complete electrical construction

"We hereby certify that the articles and services covered by this invoice were produced and performed in compliance with all applicable requirements of Section 6, 7 and 12 of the Fair Labor Standards Act, as amended, and of regulations and orders of the United States Department of Labor issued under Section 14 thereof."



Rotor Electric Company of Michigan, LLC.

9522 GRINNELL
DETROIT, MI 48213-1151
PHONE (313) 891-0331 FAX (313) 921-5310
"AN EQUAL OPPORTUNITY EMPLOYER"

INVOICE

OMID
1 PUBLIC WORKS DRIVE
WATERFORD, MI 48328-

Customer
PO Number
Professional Services Contrac

Table with columns: Job Number, Sub Job, Contract Number, Date Performed, Application Date, Application Number. Values: 719707, 0, 001, 2/11/2022, 3/22/2022, 12490

JOEL BROWN

Main invoice table with columns: Item No, Description of Work, Contract Amount, Previous Billings, Current Amount, To Date Complete & Stored, Balance To Finish, Current Retainage. Includes row for SWITCHGEAR MAINTENANCE AND TESTING and a Totals row.

2ND FLOOR RELAMPING

MINOR REPAIRS

82912 - 6010101 - 149090 - 730660 - 5807 - Ch. 21 - v#22125 - li#42614 - exp. 6/28/22

WO 524

Handwritten signature of Joel Brown

4/1/2022

Handwritten initials TM and date 3-23-22

complete electrical construction

"We hereby certify that the articles and services covered by this invoice were produced and performed in compliance with all applicable requirements of Section 6, 7 and 12 of the Fair Labor Standards Act, as amended, and of regulations and orders of the United States Department of Labor issued under Section 14 thereof."



Rotor Electric Company of Michigan, LLC.

9522 GRINNELL
DETROIT, MI 48213-1151
PHONE (313) 891-0331 FAX (313) 921-5310
"AN EQUAL OPPORTUNITY EMPLOYER"

INVOICE

OMID
1 PUBLIC WORKS DRIVE
WATERFORD, MI 48328-

Customer
PO Number
Professional Services Contrac

Table with columns: Job Number, Sub Job, Contract Number, Date Performed, Application Date, Application Number. Values: 719707, 0, 001, 1/27/2022, 3/22/2022, 12491

JOEL BROWN

Table with columns: Item No, Description of Work, Contract Amount, Previous Billings, Current Amount, To Date Complete & Stored, Balance To Finish, Current Retainage. Includes Totals and Invoice Total rows.

NEW TRANSFORMER T3
ENERGIZATION AND LOADING

82912 - 6010101 - 149090 - 730660 - 5807 - Ch. 21 -
v#22125 - li#42614 - exp. 6/28/22

WO 549

Handwritten signature of Joel Brown

4/1/2022

Handwritten initials TM

3-23-22

complete electrical construction

"We hereby certify that the articles and services covered by this invoice were produced and performed in compliance with all applicable requirements of Section 6, 7 and 12 of the Fair Labor Standards Act, as amended, and of regulations and orders of the United States Department of Labor issued under Section 14 thereof."



Rotor Electric Company of Michigan, LLC.

9522 GRINNELL
DETROIT, MI 48213-1151
PHONE (313) 891-0331 FAX (313) 921-5310
"AN EQUAL OPPORTUNITY EMPLOYER"

INVOICE

OMID
1 PUBLIC WORKS DRIVE
WATERFORD, MI 48328-

Customer
PO Number
Professional Services Contrac

Table with columns: Job Number, Sub Job, Contract Number, Date Performed, Application Date, Application Number. Values: 719707, 0, 001, 1/25/2022, 3/22/2022, 12492

JOEL BROWN

Main invoice table with columns: Item No, Description of Work, Contract Amount, Previous Billings, Current Amount, To Date Complete & Stored, Balance To Finish, Current Retainage. Includes row for SWITCHGEAR MAINTENANCE AND TESTING and a Totals row.

P2 1/21/22 TRIP EVENT

82912 - 6010101 - 149090 - 730660 - 5807 - Ch. 21 - v#22125 - li#42614 - exp. 6/28/22

WO 550

Handwritten signature of Joel Brown

4/1/2022

complete electrical construction

"We hereby certify that the articles and services covered by this invoice were produced and performed in compliance with all applicable requirements of Section 6, 7 and 12 of the Fair Labor Standards Act, as amended, and of regulations and orders of the United States Department of Labor issued under Section 14 thereof."



**Rotor Electric Company of Michigan, LLC.**

9522 GRINNELL  
 DETROIT, MI 48213-1151  
 PHONE (313) 891-0331 FAX (313) 921-5310  
 "AN EQUAL OPPORTUNITY EMPLOYER"

# INVOICE

OMID  
 1 PUBLIC WORKS DRIVE  
 WATERFORD, MI 48328-

Customer  
 PO Number  
 Professional Services Contract

Job Number	Sub Job	Contract Number	Date Performed	Application	
				Date	Number
719707	0	001	3/22/2022	3/22/2022	12493

JOEL BROWN

Item No	Description of Work	Contract Amount	Previous Billings	Current Amount	To Date Complete & Stored	Balance To Finish	Current Retainage
001	SWITCHGEAR MAINTENANCE AND TESTING	\$994.00	-	\$994.00	\$994.00	-	-
<b>Totals:</b>		<b>\$994.00</b>		<b>\$994.00</b>	<b>\$994.00</b>		
Less Retained:				-			
<b>Invoice Total:</b>				<b>\$994.00</b>			

PUMP P5 TRIP INVESTIGATION EMERGENCY

**82912 - 6010101 - 149090 - 730660 - 5807 - Ch. 21 - v#22125 - li#42614 - exp. 6/28/22**

WO 576

4/1/2022

3-23-22

complete electrical construction

"We hereby certify that the articles and services covered by this invoice were produced and performed in compliance with all applicable requirements of Section 6, 7 and 12 of the Fair Labor Standards Act, as amended, and of regulations and orders of the United States Department of Labor issued under Section 14 thereof."





Rotor Electric Company of Michigan, LLC.

9522 GRINNELL
DETROIT, MI 48213-1151
PHONE (313) 891-0331 FAX (313) 921-5310
"AN EQUAL OPPORTUNITY EMPLOYER"

INVOICE

OMID
1 PUBLIC WORKS DRIVE
WATERFORD, MI 48328-

Customer
PO Number
Professional Services Contrac

Table with columns: Job Number, Sub Job, Contract Number, Date Performed, Application Date, Application Number. Values: 719707, 0, 001, 3/4/2022, 3/22/2022, 12494

JOEL BROWN

Main invoice table with columns: Item No, Description of Work, Contract Amount, Previous Billings, Current Amount, To Date Complete & Stored, Balance To Finish, Current Retainage. Includes item 001 for SWITCHGEAR MAINTENANCE AND TESTING and a Totals row.

PUMP P6 TRIP INVESTIGATION EMERGENCY

WO 577

82912 - 6010101 - 149090 - 730660 - 5807 - Ch. 21 -
v#22125 - li#42614 - exp. 6/28/22

Handwritten signature of Joel Brown

4/1/2022

Handwritten initials TM

3-23-22

complete electrical construction

"We hereby certify that the articles and services covered by this invoice were produced and performed in compliance with all applicable requirements of Section 6, 7 and 12 of the Fair Labor Standards Act, as amended, and of regulations and orders of the United States Department of Labor issued under Section 14 thereof."



**Rotor Electric Company of Michigan, LLC.**

9522 GRINNELL  
 DETROIT, MI 48213-1151  
 PHONE (313) 891-0331 FAX (313) 921-5310  
 "AN EQUAL OPPORTUNITY EMPLOYER"

# INVOICE

OMID  
 1 PUBLIC WORKS DRIVE  
 WATERFORD, MI 48328-

**Customer**  
**PO Number**  
 Professional Services Contrac

Job Number	Sub Job	Contract Number	Date Performed	Application	
				Date	Number
719707	0	001	2/3/2022	3/22/2022	12495

JOEL BROWN

Item No	Description of Work	Contract Amount	Previous Billings	Current Amount	To Date Complete & Stored	Balance To Finish	Current Retainage
001	SWITCHGEAR MAINTENANCE AND TESTING	\$4,314.98	-	\$4,314.98	\$4,314.98	-	-
<b>Totals:</b>		<b>\$4,314.98</b>		<b>\$4,314.98</b>	<b>\$4,314.98</b>		
				Less Retained:	-		
				<b>Invoice Total:</b>	<b>\$4,314.98</b>		

BUS P4 PQM

INTEGRATION INTO SCADA

**82912 - 6010101 - 149090 - 730660 - 5807 - Ch. 21 - v#22125 - li#42614 - exp. 6/28/22**

WO 564

4/1/2022

3-23-22

complete electrical construction

"We hereby certify that the articles and services covered by this invoice were produced and performed in compliance with all applicable requirements of Section 6, 7 and 12 of the Fair Labor Standards Act, as amended, and of regulations and orders of the United States Department of Labor issued under Section 14 thereof."



**Rotor Electric Company of Michigan, LLC.**

9522 GRINNELL  
DETROIT, MI 48213-1151  
PHONE (313) 891-0331 FAX (313) 921-5310  
"AN EQUAL OPPORTUNITY EMPLOYER"

# INVOICE

OMID  
1 PUBLIC WORKS DRIVE  
WATERFORD, MI 48328-

Customer  
PO Number  
Professional Services Contrac

Job Number	Sub Job	Contract Number	Date Performed	Application	
				Date	Number
719707	0	001	3/10/2022	3/22/2022	12496

JOEL BROWN

Item No	Description of Work	Contract Amount	Previous Billings	Current Amount	To Date Complete & Stored	Balance To Finish	Current Retainage
001	SWITCHGEAR MAINTENANCE AND TESTING	\$4,628.11	-	\$4,628.11	\$4,628.11	-	-
<b>Totals:</b>		<b>\$4,628.11</b>		<b>\$4,628.11</b>	<b>\$4,628.11</b>		
Less Retained:				-			
<b>Invoice Total:</b>				<b>\$4,628.11</b>			

P2 SHELTER HVAC CIRCUITS

**82912 - 6010101 - 149090 - 730660 - 5807 - Ch. 21 - v#22125 - li#42614 - exp. 6/28/22**

WO 565

4/1/2022

3-23-22

complete electrical construction

"We hereby certify that the articles and services covered by this invoice were produced and performed in compliance with all applicable requirements of Section 6, 7 and 12 of the Fair Labor Standards Act, as amended, and of regulations and orders of the United States Department of Labor issued under Section 14 thereof."



Rotor Electric Company of Michigan, LLC.

9522 GRINNELL
DETROIT, MI 48213-1151
PHONE (313) 891-0331 FAX (313) 921-5310
"AN EQUAL OPPORTUNITY EMPLOYER"

INVOICE

OMID
1 PUBLIC WORKS DRIVE
WATERFORD, MI 48328-

Customer
PO Number
Professional Services Contrac

Table with columns: Job Number, Sub Job, Contract Number, Date Performed, Application Date, Application Number. Values: 719707, 0, 001, 1/24/2022, 3/30/2022, 12497

JOEL BROWN

Main invoice table with columns: Item No, Description of Work, Contract Amount, Previous Billings, Current Amount, To Date Complete & Stored, Balance To Finish, Current Retainage. Includes item 001 for SWITCHGEAR MAINTENANCE AND TESTING and a Totals row.

P2 1/21/22 TRIP EVENT

TJM 3-30-22

WO 550

82912 - 6010101 - 149090 - 730660 - 5807 - Ch. 21 - v#22125 - li#42614 - exp. 6/28/22

Handwritten signature of Joel Brown

4/1/2022

complete electrical construction

"We hereby certify that the articles and services covered by this invoice were produced and performed in compliance with all applicable requirements of Section 6, 7 and 12 of the Fair Labor Standards Act, as amended, and of regulations and orders of the United States Department of Labor issued under Section 14 thereof."

## **Agenda Item No. 12**

Other Business

**Agenda Item No. 13**

Adjourn